

# HI-DUTY ALUMINUM STOCK PICKER TRUCK - SPA-HD-2252

APPROX WEIGHT: 126.59 lbs. DOES NOT INCLUDE WEIGHT OF POWER OR PACKAGING!!!

\*\*\* ANY ADDITIONS, DELETIONS, OR OMISSIONS MUST BE CORRECTED ON THIS DRAWING AS THIS DRAWING WILL BE CONSIDERED ALL INCLUSIVE \*\*\*  
 ALL GRAPHICS PROVIDED ARE FOR REFERENCE ONLY. IF CERTAIN DIMENSIONS ARE CRITICAL PLEASE VERIFY THOSE DIMENSIONS WITH YOUR SALESPERSON

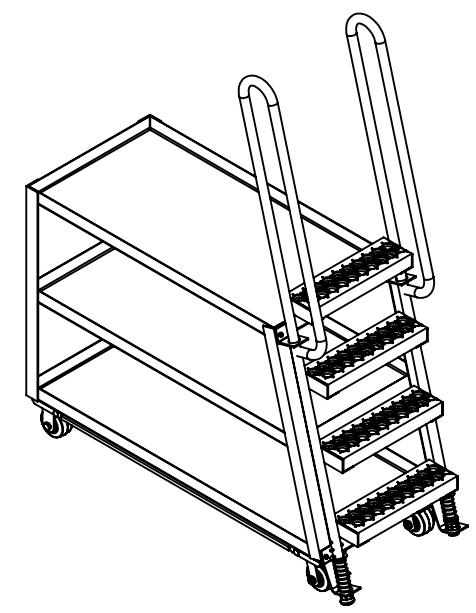
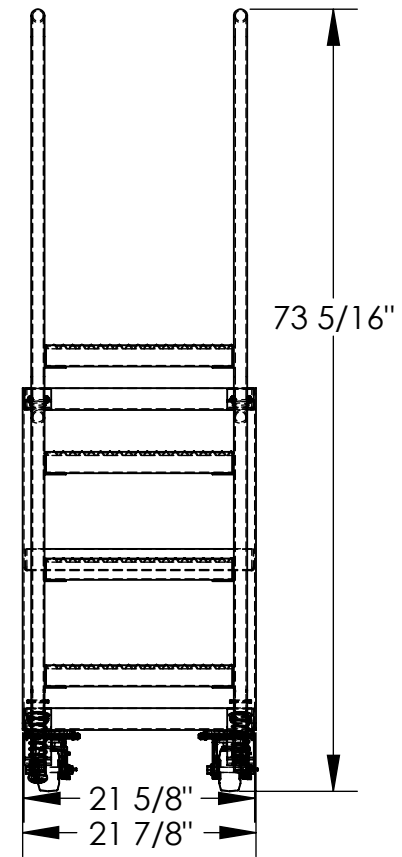
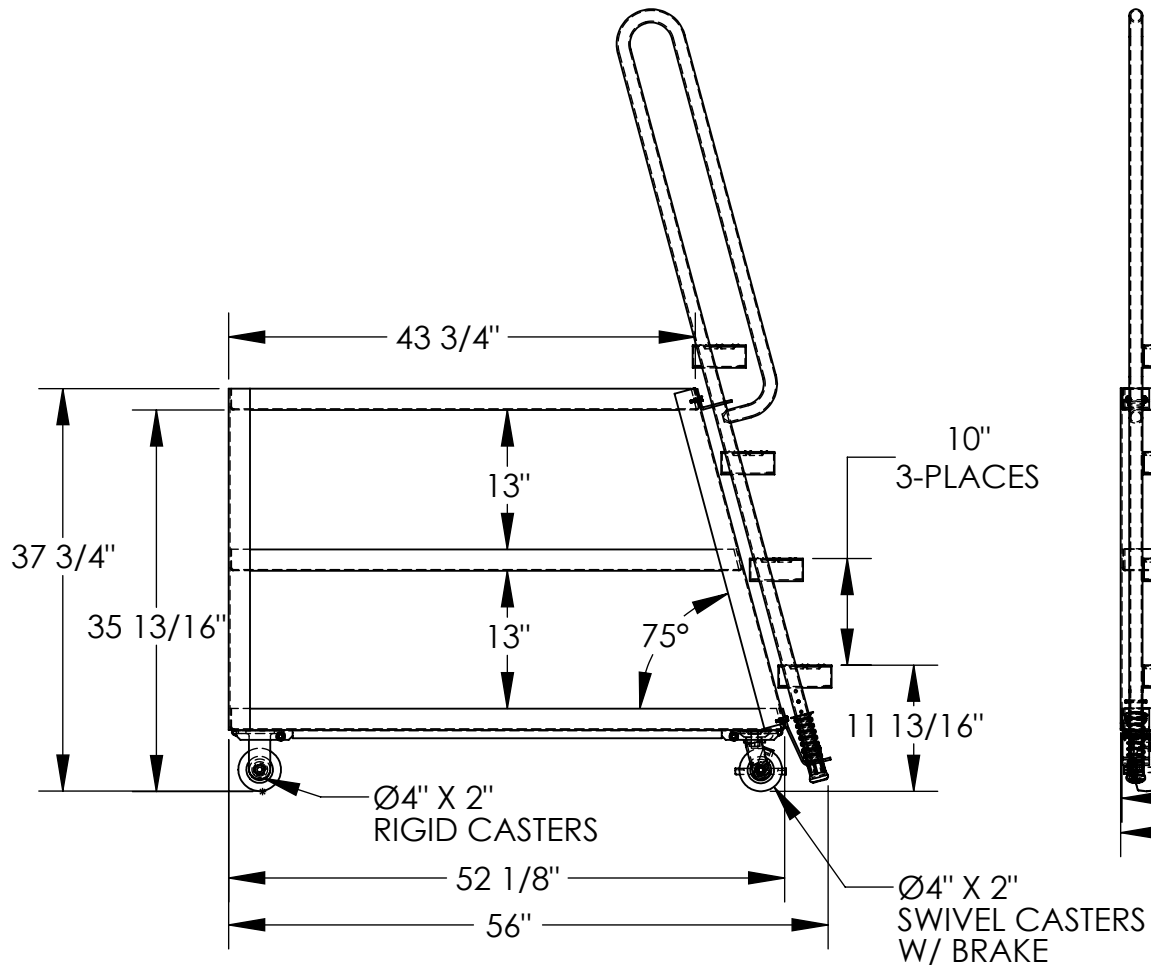

3D SHOWN FOR REFERENCE ONLY  
 DIMENSION TOLERANCE ± 1/4"

## STANDARD FEATURES

- MODEL NUMBER IS SPA-HD-2252
- CAPACITY: 500 LBS. (330 LBS. PER SHELF)
- OVERALL WIDTH IS 21 7/8"
- OVERALL LENGTH IS 56"
- OVERALL HEIGHT IS 73 5/16"
- BOTTOM SHELF SIZE: 21 5/8" x 52 1/8"
- TOP SHELF SIZE: 21 5/8" x 43 3/4"
- TOP SHELF HEIGHT: 37 3/4"
- SHELF CLEARANCE: 13"
- (2) 4x2 MOLD-ON-RUBBER SWIVEL CASTER WITH BRAKE
- (2) 4x2 MOLD-ON-RUBBER RIGID CASTER
- ALUMINUM FRAME CONSTRUCTION
- TOUGH BAKED IN POWDER COATED GRAY FINISH LADDER

## SPECIAL FEATURES

NONE

APPROVAL

I, THE UNDERSIGNED, AGREE THAT THE PRODUCT AS REPRESENTED SATISFIES DESIGN AND DIMENSION REQUIREMENTS. I ALSO ACKNOWLEDGE MY DUTY TO CONFIRM PRODUCT AND INSTALLATION COMPLIANCE WITH ALL APPLICABLE FEDERAL, STATE AND LOCAL REGULATIONS AND STANDARDS.  
**UNITS REQUIRING APPROVAL DRAWINGS OR MODIFIED ARE NON-RETURNABLE**  
 As drawn       As marked

Signed: \_\_\_\_\_ Date: \_\_\_\_\_

Printed Name: \_\_\_\_\_

LEAD TIME WILL START UPON RECEIPT OF SIGNED APPROVAL DRAWING

DISTRIBUTOR'S NAME:		P.O.#
VESTIL MANUFACTURING		X
DRAWN BY: CA	DATE: 04/09/2015	W.O.#
REFERENCE: X	SCALE: 1:18	X
QUOTED LEAD TIME: X	QUOTE #	SALES: X
	X	FILE NAME:
		32-007-039