

SNM-62-FA (Narrow Mast Fully Electric Stacker with Adjustable Forks & Fixed Legs)

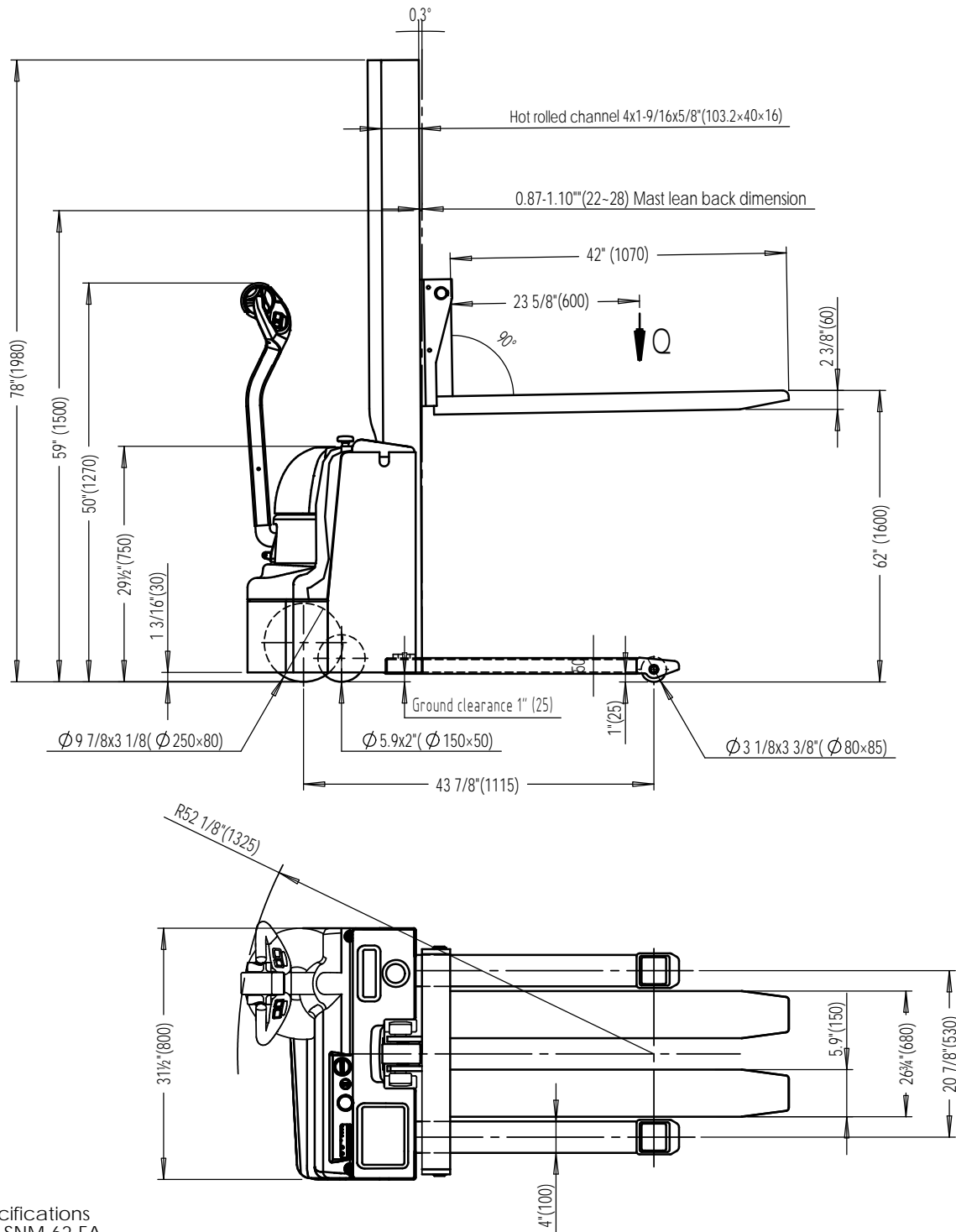

Specifications

Model # SNM-62-FA
 Capacity (UDL): 2,200 lbs
 Lift height: 62"
 Lowered height: 2 3/8"
 Adjustable Forks & Fixed legs
 Overall mast height: 78 3/4"
 Drive wheel: Ø10x3"
 Front wheel: Ø3 1/8x3 3/8"
 Stabilizer wheel: Ø5.9x2.0"
 Handle: CH-2
 Drive Motor: DC24V/0.7Kw
 Lift Motor: DC24V/2.0Kw
 Battery: 2x12V/80-95Ah
 Battery Charger: 24V/12amp
 Travel Speed w/load: 2.8m/h
 Travel Speed w/o load: 3.4m/h

| | |
|----------------------------|---|
| VESTIL MANUFACTURING CORP. | |
| Model: | SNM-62-FA |
| Descrip: | Narrow Mast Fully Electric Stacker with Adjustable Forks & Fixed Legs |
| Design: | T.M |
| Date: | 01/05/17 |