

AC POWERED HYDRAULIC SCISSOR LIFT TABLE - SCTAB-2000-2040-AC

APPROX WEIGHT: 291.88 lbs. DOES NOT INCLUDE WEIGHT OF POWER OR PACKAGING!!!

*** ANY ADDITIONS, DELETIONS, OR OMISSIONS MUST BE CORRECTED ON THIS DRAWING AS THIS DRAWING WILL BE CONSIDERED ALL INCLUSIVE ***
 ALL GRAPHICS PROVIDED ARE FOR REFERENCE ONLY. IF CERTAIN DIMENSIONS ARE CRITICAL PLEASE VERIFY THOSE DIMENSIONS WITH YOUR SALESPERSON

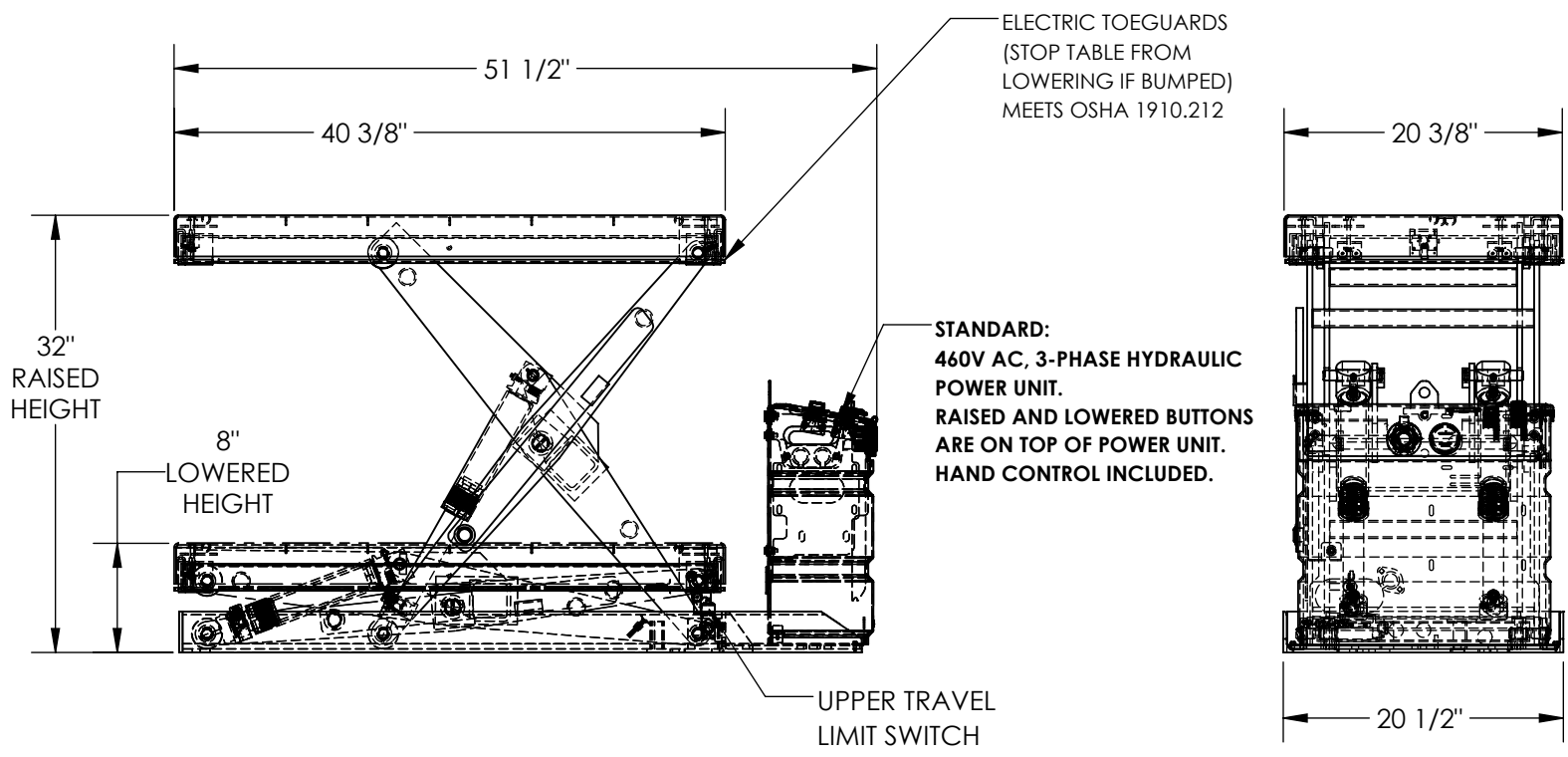

DECK TOLERANCE ±1/2"
 TABLE HEIGHT TOLERANCES ±1/2"
 DECK FLATNESS ±1/4"

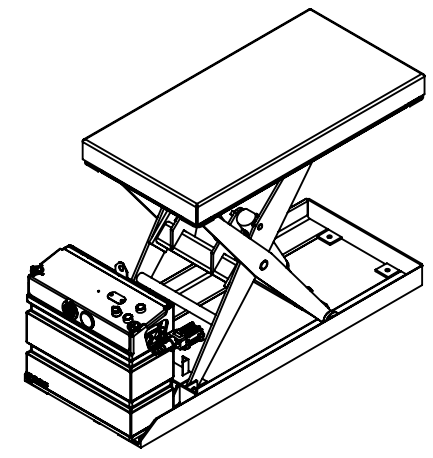
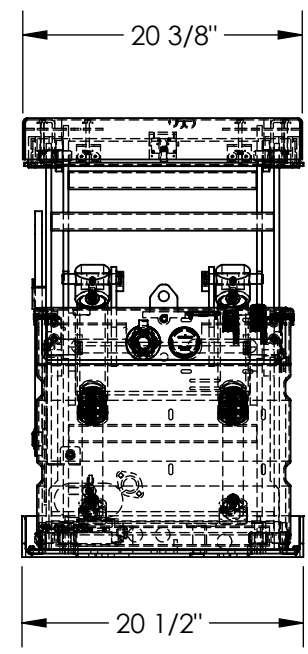

STANDARD FEATURES

- MODEL NUMBER IS SCTAB-2000-2040-AC
- DECK WIDTH IS 20 3/8"
- DECK LENGTH IS 40 3/8"
- RAISED HEIGHT IS 32"
- LOWERED HEIGHT IS 8"
- TABLE CAPACITY (EVENLY DISTRIBUTED)
- MAX CAPACITY IS 2,000 LBS.
- CONTROL IS HANDHELD 2 BUTTON, NEMA 4 PENDANT WITH MINIMUM 8' USABLE COIL CORD
- SAFETY MAINTENANCE PROPS, DISPLACEMENT STYLE CYLINDERS INSTALLED ROD DOWN
- EMERGENCY SAFETY STOP HYDRAULIC FUSES
- UPPER TRAVEL LIMIT SWITCH
- ELECTRIC PINCH POINT GUARD
- DURABLE LIQUID PAINT BLUE FINISH

SPECIAL FEATURES

NONE

PLEASE CIRCLE SPECIFICATIONS:

POWER	AC	DC (12V)	AIR/OIL
MOTOR VOLTAGE	115	208	230 460
DEDICATED CIRCUIT REQUIRED 60Hz			
MOTOR PHASE	SINGLE	THREE	
CONTROL	HAND	FOOT	

APPROVAL

I, THE UNDERSIGNED, AGREE THAT THE PRODUCT AS REPRESENTED SATISFIES DESIGN AND DIMENSION REQUIREMENTS. I ALSO ACKNOWLEDGE MY DUTY TO CONFIRM PRODUCT AND INSTALLATION COMPLIANCE WITH ALL APPLICABLE FEDERAL, STATE AND LOCAL REGULATIONS AND STANDARDS.
ANY MODIFIED UNITS ARE NON-RETURNABLE
 As drawn As marked

Signed: _____ Date: _____
 Printed Name: _____
 LEAD TIME WILL START UPON RECEIPT OF SIGNED APPROVAL DRAWING

DIMENSION TOLERANCE ± 1/4"

FOR INTERNAL USE ONLY PROJECT SIGN OFF	
SALES	
ENG.	
FAB.	
POWER	

DISTRIBUTOR'S NAME:		P.O.#
VESTIL MANUFACTURING		X
DRAWN BY: CA	DATE: 10/12/2017	W.O.#
REFERENCE: X	SCALE: 1:14	X
QUOTED LEAD TIME: X	QUOTE #	SALES: X
	X	FILE NAME:
		01-007-396