

ECONOMY SPREADER BEAM W/ MAGNETIC LIFTERS - SBM-20-4-ML

APPROX WEIGHT: 181.54 lbs.
 DOES NOT INCLUDE WEIGHT OF POWER OR PACKAGING!!!

*** ANY ADDITIONS, DELETIONS, OR OMISSIONS MUST BE CORRECTED ON THIS DRAWING AS THIS DRAWING WILL BE CONSIDERED ALL INCLUSIVE ***

ALL GRAPHICS PROVIDED ARE FOR REFERENCE ONLY. IF CERTAIN DIMENSIONS ARE CRITICAL PLEASE VERIFY THOSE DIMENSIONS WITH YOUR SALESPERSON

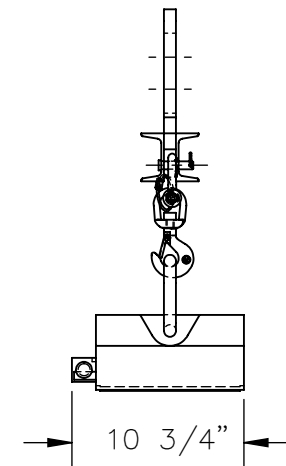
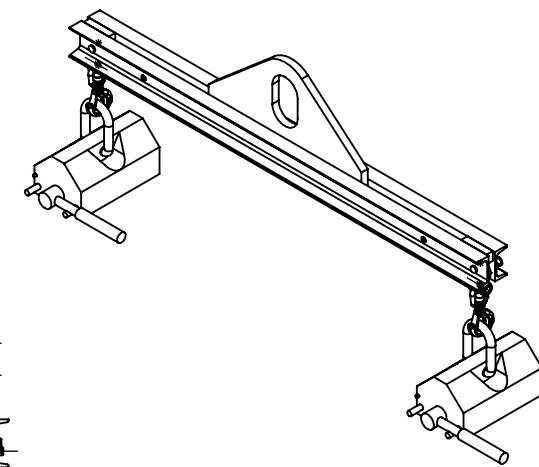
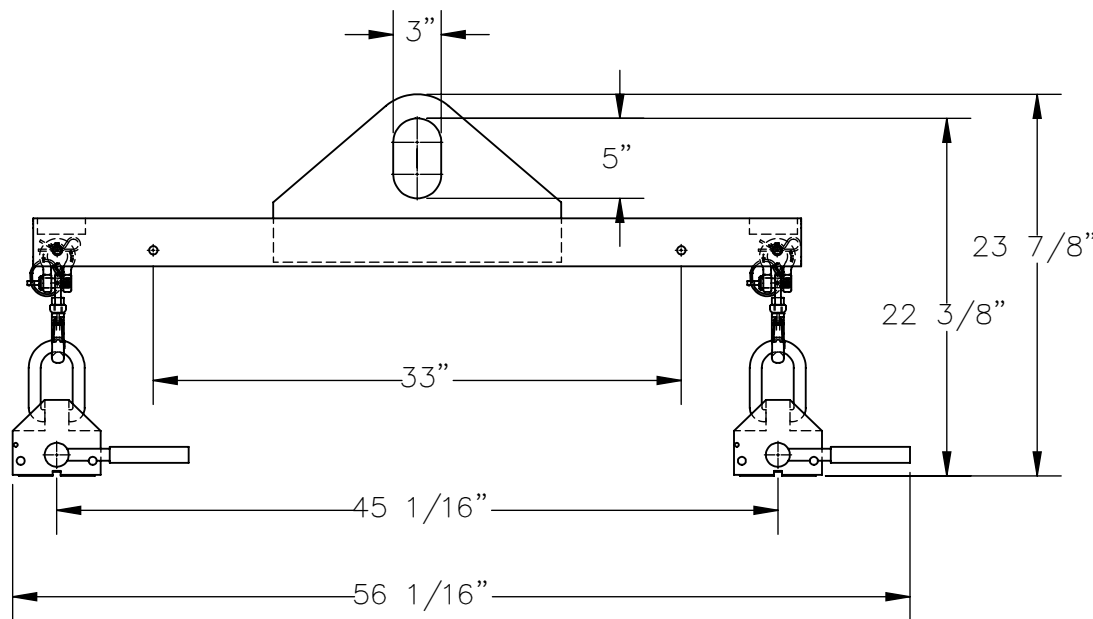

DIMENSION TOLERANCE ± 1/4"

STANDARD FEATURES

- MODEL NUMBER IS SBM-20-4-ML
- OVERALL WIDTH IS 10 3/4"
- OVERALL HEIGHT IS 23 7/8"
- OVERALL LENGTH IS 56 1/16"
- USABLE BAIL IS 3"x5"
- MINIMUM SPREAD IS 33"
- MAXIMUM SPREAD IS 45 1/16"
- HEADROOM IS 22 3/8"
- MAX UNIFORM FLAT CAPACITY IS 2000 LBS.
- MAX UNIFORM ROUND CAPACITY IS 800 LBS.
- SPREADER BEAM TOUGH BAKED IN POWDER COAT BLUE FINISH
- MAGNET LIFTERS TOUGH BAKED IN POWDER COAT YELLOW FINISH

SPECIAL FEATURES

NONE

APPROVAL	I, THE UNDERSIGNED, AGREE THAT THE PRODUCT AS REPRESENTED SATISFIES DESIGN AND DIMENSION REQUIREMENTS. I ALSO ACKNOWLEDGE MY DUTY TO CONFIRM PRODUCT AND INSTALLATION COMPLIANCE WITH ALL APPLICABLE FEDERAL, STATE AND LOCAL REGULATIONS AND STANDARDS.	
	ANY MODIFIED UNITS ARE NON-RETURNABLE	
	[] As drawn [] As marked	
	Signed: _____ Date: _____	
Printed Name: _____		
LEAD TIME WILL START UPON RECEIPT OF SIGNED APPROVAL DRAWING		

FOR INTERNAL USE ONLY PROJECT SIGN OFF	
SALES	
ENG.	
FAB.	
POWER	

DISTRIBUTOR'S NAME:		P.O.#
VESTIL MANUFACTURING		X
DRAWN BY: JGP		DATE: 03/30/2020
REFERENCE: X		SCALE: 1:12
QUOTED LEAD TIME: X		QUOTE # X
		W.O.# X
		SALES: X
		FILE NAME: 08-007-452