

PORTABLE SCISSOR TABLE - PST-2464-1-58

APPROX WEIGHT: 1043.94 lbs.
 DOES NOT INCLUDE WEIGHT OF POWER OR PACKAGING!!!

ANY ADDITIONS, DELETIONS, OR OMISSIONS MUST BE CORRECTED ON THIS DRAWING AS THIS DRAWING WILL BE CONSIDERED ALL INCLUSIVE

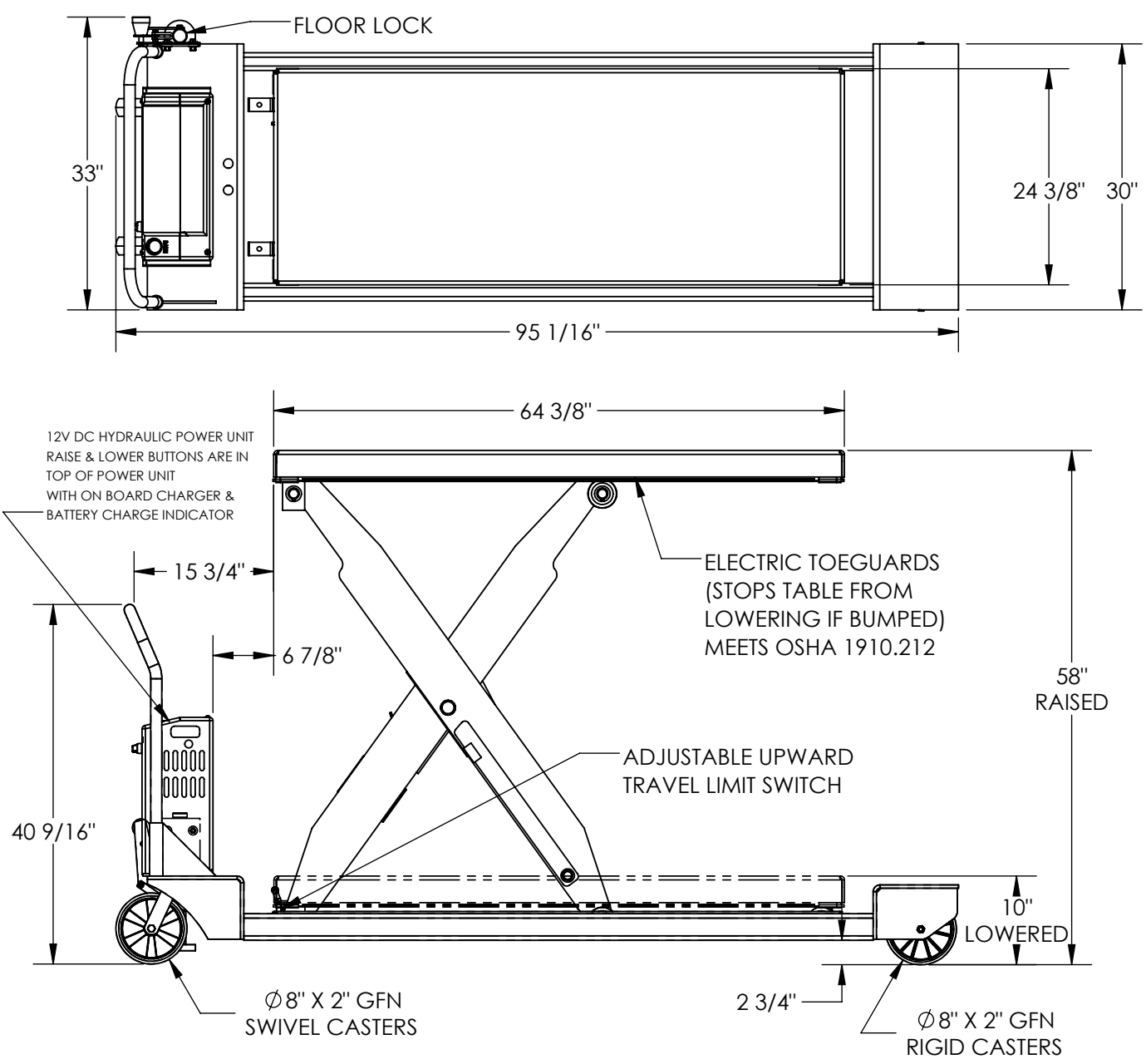

ALL GRAPHICS PROVIDED ARE FOR REFERENCE ONLY. IF CERTAIN DIMENSIONS ARE CRITICAL PLEASE VERIFY THOSE DIMENSIONS WITH YOUR SALESPERSON

DIMENSION TOLERANCE ± 1/2"
 TABLE HEIGHT TOLERANCE ± 1/2"
 DECK FLATNESS ± 1/4"

- STANDARD FEATURES**
 MODEL NUMBER: PST-2464-1-58
 CAPACITY: 1,000 LBS
 PLATFORM WIDTH: 24 3/8"
 PLATFORM LENGTH: 64 3/8"
 PLATFORM LOWERED HEIGHT: 10"
 PLATFORM RAISED HEIGHT: 58"
 OVERALL WIDTH: 33"
 OVERALL LENGTH: 95 1/16"
 GROUND CLEARANCE: 2 3/4"
 CASTERS: TWO Ø8" X 2" GFN SWIVEL
 TWO Ø8" X 2" GFN RIGID
 12V DC POWER UNIT W/ ON-BOARD CHARGER & BATTERY CHARGE INDICATOR
 DURABLE LIQUID PAINT BLUE FINISH

SPECIAL FEATURES
 NONE

APPROVAL

I, THE UNDERSIGNED, AGREE THAT THE PRODUCT AS REPRESENTED SATISFIES DESIGN AND DIMENSION REQUIREMENTS. I ALSO ACKNOWLEDGE MY DUTY TO CONFIRM PRODUCT AND INSTALLATION COMPLIANCE WITH ALL APPLICABLE FEDERAL, STATE AND LOCAL REGULATIONS AND STANDARDS.

UNITS REQUIRING APPROVAL DRAWINGS OR MODIFIED ARE NON-RETURNABLE

As drawn As marked

Signed: _____ Date: _____

Printed Name: _____

LEAD TIME WILL START UPON RECEIPT OF SIGNED APPROVAL DRAWING

DISTRIBUTOR'S NAME:		P.O.#	
VESTIL MANUFACTURING		X	
DRAWN BY: KGH		DATE: 5/9/2018	SALES: X
REFERENCE: X	SCALE: 1:18	FILE NAME:	
QUOTED LEAD TIME: X	QUOTE # X	01-007-379	