

ADJUSTABLE PALLET STAND - PS-4045/CA-CK

APPROX WEIGHT: 321.60 lbs.
DOES NOT INCLUDE WEIGHT OF POWER OR PACKAGING!!!

*** ANY ADDITIONS, DELETIONS, OR OMISSIONS MUST BE CORRECTED ON THIS DRAWING AS THIS DRAWING WILL BE CONSIDERED ALL INCLUSIVE ***

ALL GRAPHICS PROVIDED ARE FOR REFERENCE ONLY. IF CERTAIN DIMENSIONS ARE CRITICAL PLEASE VERIFY THOSE DIMENSIONS WITH YOUR SALESPERSON

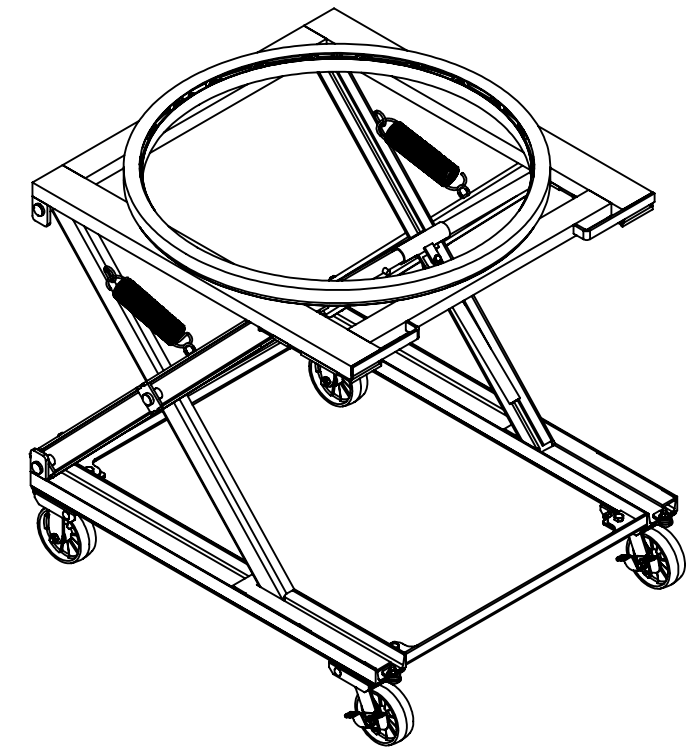
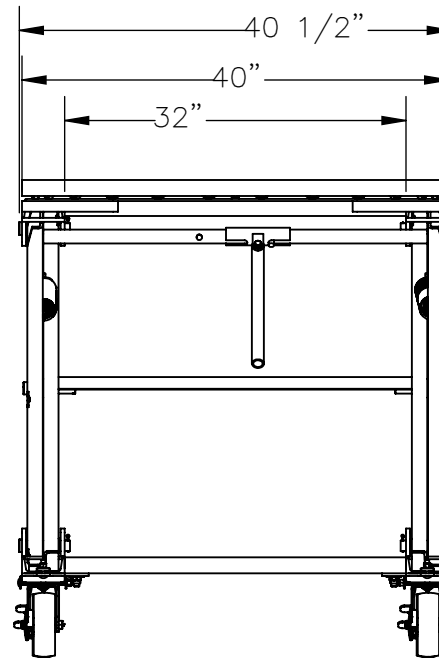
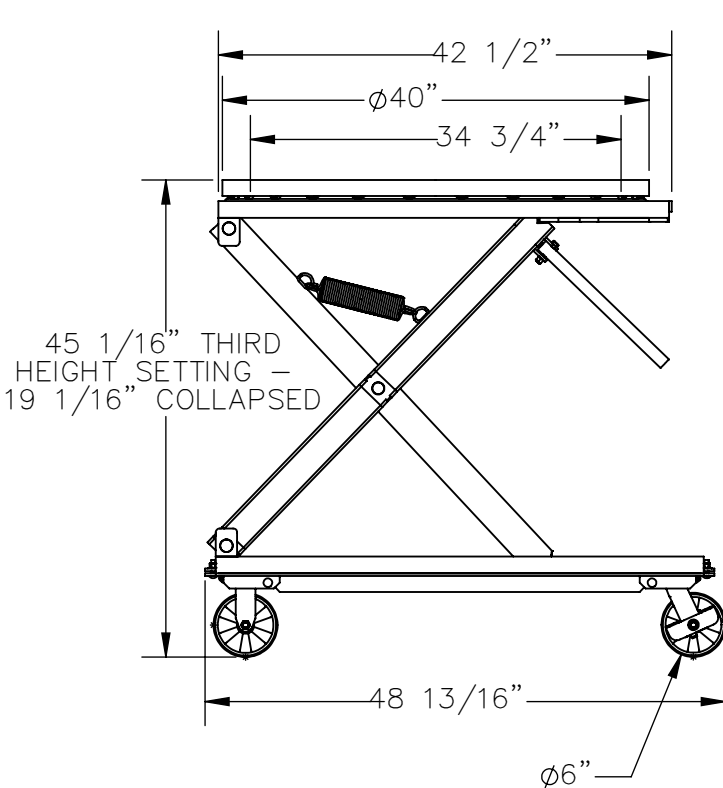

DIMENSION TOLERANCE $\pm 1/4$ "

STANDARD FEATURES

MODEL NUMBER IS PS-4045/CA-CK
CAPACITY IS 1,500 POUNDS
OVERALL WIDTH IS 40 1/2"
PLATFORM WIDTH IS 40"
OVERALL LENGTH IS 48 13/16"
PLATFORM LENGTH IS 42 1/2"
THIRD HEIGHT SETTING IS 45 1/16"
SECOND HEIGHT SETTING IS 39 5/16"
FIRST HEIGHT SETTING IS 29 1/16"
COLLAPSED HEIGHT IS 19 1/16"
 $\phi 40$ " MANUAL CAROUSEL ROTATES 360°
(4) $\phi 6$ " GFN CASTERS - 2 SWIVEL, 2 RIGID
TOUGH BAKED IN POWDER COATED BLUE FINISH

SPECIAL FEATURES

NONE

APPROVAL

I, THE UNDERSIGNED, AGREE THAT THE PRODUCT AS REPRESENTED SATISFIES DESIGN AND DIMENSION REQUIREMENTS. I ALSO ACKNOWLEDGE MY DUTY TO CONFIRM PRODUCT AND INSTALLATION COMPLIANCE WITH ALL APPLICABLE FEDERAL, STATE AND LOCAL REGULATIONS AND STANDARDS.

ANY MODIFIED UNITS ARE NON-RETURNABLE

As drawn As marked

Signed: _____ Date: _____

Printed Name: _____

LEAD TIME WILL START UPON RECEIPT OF SIGNED APPROVAL DRAWING

FOR INTERNAL USE ONLY PROJECT SIGN OFF	
SALES	
ENG.	
FAB.	
POWER	

DISTRIBUTOR'S NAME:		P.O.#
VESTIL MANUFACTURING		X
DRAWN BY: JLH		W.O.#
DATE: 5/30/18		X
REFERENCE: X	SCALE: 1:18	SALES: X
QUOTED LEAD TIME: X	QUOTE #	FILE NAME:
	X	15-007-150