

PANEL TRUCK W/STORAGE TRAY - PRCT-T-2448-MR

APPROX WEIGHT: 157.37 lbs.
DOES NOT INCLUDE WEIGHT OF POWER OR PACKAGING!!!

*** ANY ADDITIONS, DELETIONS, OR OMISSIONS MUST BE CORRECTED ON THIS DRAWING AS THIS DRAWING WILL BE CONSIDERED ALL INCLUSIVE ***

ALL GRAPHICS PROVIDED ARE FOR REFERENCE ONLY. IF CERTAIN DIMENSIONS ARE CRITICAL PLEASE VERIFY THOSE DIMENSIONS WITH YOUR SALESPERSON

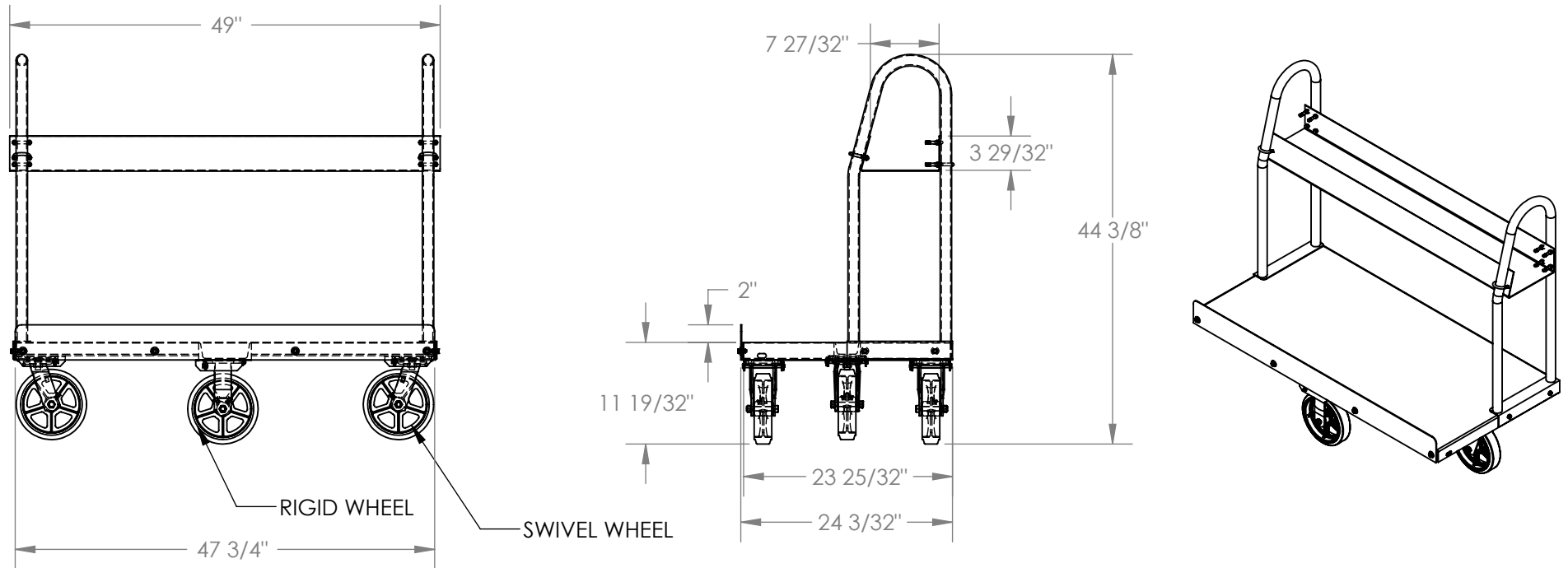

STANDARD FEATURES

- MODEL NUMBER IS PRCT-T-2448-MR
- CAPACITY IS: 1,000 LBS.
- OVERALL WIDTH IS: 24 3/32"
- OVERALL (DECK) WIDTH IS 23 25/32"
- OVERALL LENGTH IS: 49"
- OVERALL (DECK) LENGTH IS: 47 3/4"
- OVERALL HEIGHT IS: 44 3/8"
- DECK HEIGHT IS: 11 19/32"
- USABLE STORAGE TRAY WIDTH IS: 7 27/32"
- MIN. USABLE STORAGE TRAY LENGTH IS: 49"
- USABLE STORAGE TRAY HEIGHT IS: 3 29/32"
- DECK INCLUDES 2" HIGH LIP FOR HOLDING SHEET GOODS
- DECK OPENING CAN HOLD PANELS UP TO 11" THICK
- TWO RIGID AND TWO SWIVEL 8" DIA. MOLD-ON RUBBER CASTERS IN DIAMOND PATTERN
- STEEL CONSTRUCTION WITH POWDER COAT BLUE FINISH

SPECIAL FEATURES

NONE

DIMENSION TOLERANCE ± 1/4"

APPROVAL	I, THE UNDERSIGNED, AGREE THAT THE PRODUCT AS REPRESENTED SATISFIES DESIGN AND DIMENSION REQUIREMENTS. I ALSO ACKNOWLEDGE MY DUTY TO CONFIRM PRODUCT AND INSTALLATION COMPLIANCE WITH ALL APPLICABLE FEDERAL, STATE AND LOCAL REGULATIONS AND STANDARDS.	
	ALL SPECIAL UNITS ARE NON-RETURNABLE	
	[] As drawn [] As marked	
Signed: _____		Date: _____
LEAD TIME WILL START UPON RECEIPT OF SIGNED APPROVAL DRAWING		

FOR INTERNAL USE ONLY PROJECT SIGN OFF	
SALES	
ENG.	
FAB.	
POWER	

DISTRIBUTOR'S NAME:		P.O.#
VESTIL MANUFACTURING		X
DRAWN BY:	DATE:	W.O.#
C.CLEMENS	5/27/15	X
REFERENCE:	SCALE:	FILE NAME:
X	1:18	
QUOTED LEAD TIME:	QUOTE #	
X	X	16-007-197