



Vestil Manufacturing Corp.
 2999 North Wayne Street, P.O. Box 507, Angola, IN 46703
 Telephone: (260) 665-7586 -or- Toll Free (800) 348-0868
 Fax: (260) 665-1339
 Web: www.vestilmfg.com e-mail: info@vestil.com

PRCT-T SERIES



Receiving Instructions

After delivery, remove the packaging from the product. Inspect the product closely to determine whether it sustained damage during transport. If damage is discovered, record a complete description of it on the bill of lading. If the product is undamaged, discard the packaging.

NOTE: The end-user is solely responsible for confirming that product design, use, and maintenance comply with laws, regulations, codes, and mandatory standards applied where the product is used.

Technical Service & Replacement Parts

For answers to questions not addressed in these instructions and to order replacement parts, labels, and accessories, call our Technical Service and Parts Department at (260) 665-7586. The Department can also be contacted online at <https://www.vestil.com/page-parts-request.php>.

Electronic Copies of Instruction Manuals

Additional copies of this instruction manual may be downloaded from <https://www.vestil.com/page-manuals.php>.

Table of Contents		Page
Signal Words		2
Safety Instructions		2
Using the Product		2
Exploded View and Bill of Materials		3-4
Record of Satisfactory Condition		5
Inspections & Maintenance		5
Labeling Diagram		5
Limited Warranty		6

SPECIFICATIONS

Specifications for PRCT-T-series carts are provided on Vestil's website. To access the appropriate specifications document, navigate to this webpage: <https://www.vestil.com/product.php?FID=969>. Click the "Specifications" tab. Scroll the page to the entry for the model you purchased, and click the button in the PDF column that looks like a pencil inside a blue box. A PDF file will open. This file is the specifications document. Print a copy of the document and keep it with your copy of this manual. The following is an exemplar specifications document for model PRCT-T (16-007-197).

PANEL TRUCK W/STORAGE TRAY - PRCT-T-2448-MR

*** ANY ADDITIONS, DELETIONS, OR OMISSIONS MUST BE CORRECTED ON THIS DRAWING AS THIS DRAWING WILL BE CONSIDERED ALL INCLUSIVE ***
ALL GRAPHICS PROVIDED ARE FOR REFERENCE ONLY. IF CERTAIN DIMENSIONS ARE CRITICAL PLEASE VERIFY THOSE DIMENSIONS WITH YOUR SALESPERSON

APPROX WEIGHT: 190.70 lbs.
DOES NOT INCLUDE WEIGHT OF POWER OR PACKAGING!!!

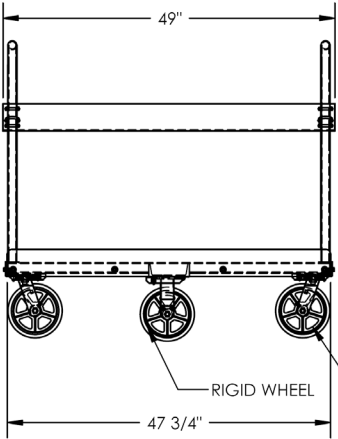
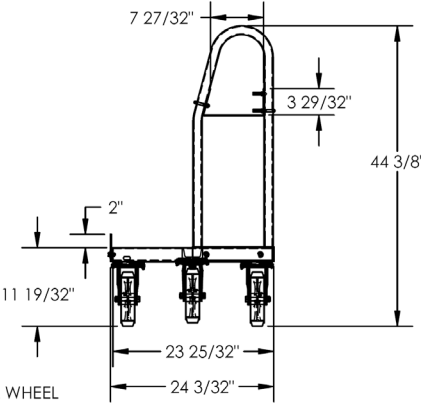
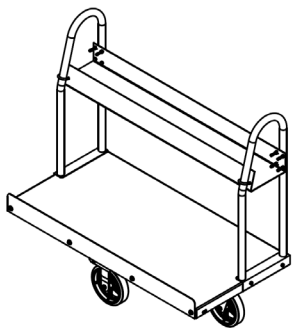
STANDARD FEATURES

MODEL NUMBER IS PRCT-T-2448-MR
 CAPACITY IS: 1,000 LBS.
 OVERALL WIDTH IS: 24 3/32"
 OVERALL (DECK) WIDTH IS 23 25/32"
 OVERALL LENGTH IS: 49"
 OVERALL (DECK) LENGTH IS: 47 3/4"
 OVERALL HEIGHT IS: 44 3/8"
 DECK HEIGHT IS: 11 19/32"
 USABLE STORAGE TRAY WIDTH IS: 7 27/32"
 MIN. USABLE STORAGE TRAY LENGTH IS: 49"
 USABLE STORAGE TRAY HEIGHT IS: 3 29/32"
 DECK INCLUDES 2" HIGH LIP FOR HOLDING SHEET GOODS
 DECK OPENING CAN HOLD PANELS UP TO 11" THICK
 TWO RIGID AND TWO SWIVEL 8" DIA. MOLD-ON RUBBER CASTERS IN DIAMOND PATTERN
 STEEL CONSTRUCTION WITH POWDER COAT BLUE FINISH

SPECIAL FEATURES

NONE

DIMENSION TOLERANCE ± 1/4"

I, THE UNDERSIGNED, AGREE THAT THE PRODUCT AS REPRESENTED SATISFIES DESIGN AND DIMENSION REQUIREMENTS. I ALSO ACKNOWLEDGE MY DUTY TO CONFIRM PRODUCT AND INSTALLATION COMPLIANCE WITH ALL APPLICABLE FEDERAL, STATE AND LOCAL REGULATIONS AND STANDARDS.
ALL SPECIAL UNITS ARE NON-RETURNABLE
 As drawn As marked

Signed: _____ Date: _____

LEAD TIME WILL START UPON RECEIPT OF SIGNED APPROVAL DRAWING

FOR INTERNAL USE ONLY PROJECT SIGN OFF	DISTRIBUTOR'S NAME: VESTIL MANUFACTURING	P.O.# X
SALES	DRAWN BY:	W.O.# X
ENG.	DATE:	SALES: X
FAB.	REFERENCE: X	FILE NAME:
POWER	QUOTED LEAD TIME: X	SCALE: 1:18
	QUOTE # X	16-007-197

SIGNAL WORDS

This manual uses SIGNAL WORDS to direct the reader's attention to important safety-related messages. These messages describe uses of the product that could result in personal injury or property damage. Each signal word corresponds to a specific hazard level.



Identifies a hazardous situation which, if not avoided, WILL result in DEATH or SERIOUS INJURY. Use of this signal word is limited to the most extreme situations.



Identifies a hazardous situation which, if not avoided, COULD result in DEATH or SERIOUS INJURY.



Indicates a hazardous situation which, if not avoided, COULD result in MINOR or MODERATE injury.



Identifies practices likely to result in product/property damage, such as operation that might damage the product.

EXPLODED VIEW AND BILL OF MATERIALS (PRCT-T-2448-MR/PU) 16-006-197 & 16-006-198

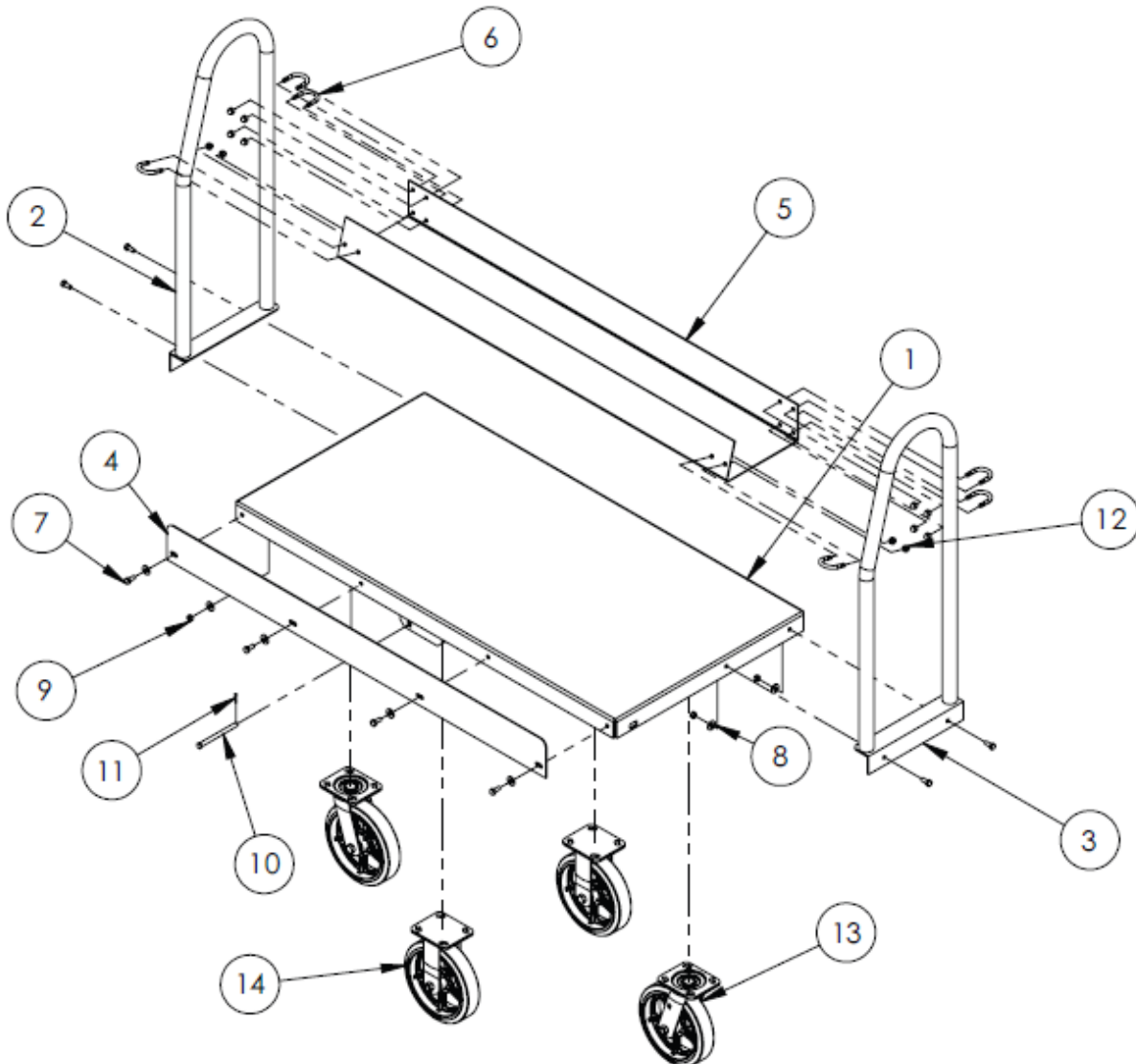

ITEM NO.	PART NO.	DESCRIPTION	QTY.
1	16-514-136	FRAME, WELDMENT, PANEL TRUCK	1
2	16-525-024	WELDMENT, HANDLE, LEFT	1
3	16-525-025	WELDMENT, HANDLE, RIGHT	1
4	16-024-005	GUARD, PANEL TRUCK	1
5	16-013-058	DECK, FORMED, STORAGE TRAY	1
6	16-145-016	5/16-18 U-BOLT FOR 1" PIPE	6
7	11053	5/16-18 X 3/4 LG, HHCS #2 Z PLATED	8
8	33006	FLAT WASHER, ZINC PLATED, USS, 5/16"	12
9	36104	HEX NT, GRADE A, ZINC PLATED, 5/16-18	8
10	99-112-006	CLEVIS PIN	4
11	65073	COTTER PIN, ZINC FINISH, 1/8 X 5/8"	4
12	37709	ACORN NUT, 5/16-18	12
13	16-132-041	PRCT-T-2448-MR: CASTER, SWIVEL, 8 X 2, MOLD ON RUBBER	2
	16-132-038	PRCT-T-2448-PU: CASTER, SWIVEL, 8 X 2, POLY ON STEEL	2
14	16-132-042	PRCT-T-2448-MR: CASTER, RIGID, 8 X 2, MOLD ON RUBBER	2
	16-132-039	PRCT-T-2448-PU: CASTER, RIGID, 8 X 2, POLY ON STEEL	2

EXPLODED VIEW AND BILL OF MATERIALS (PRCT-T-3060-MR/PU) 16-006-199 & 16-006-200

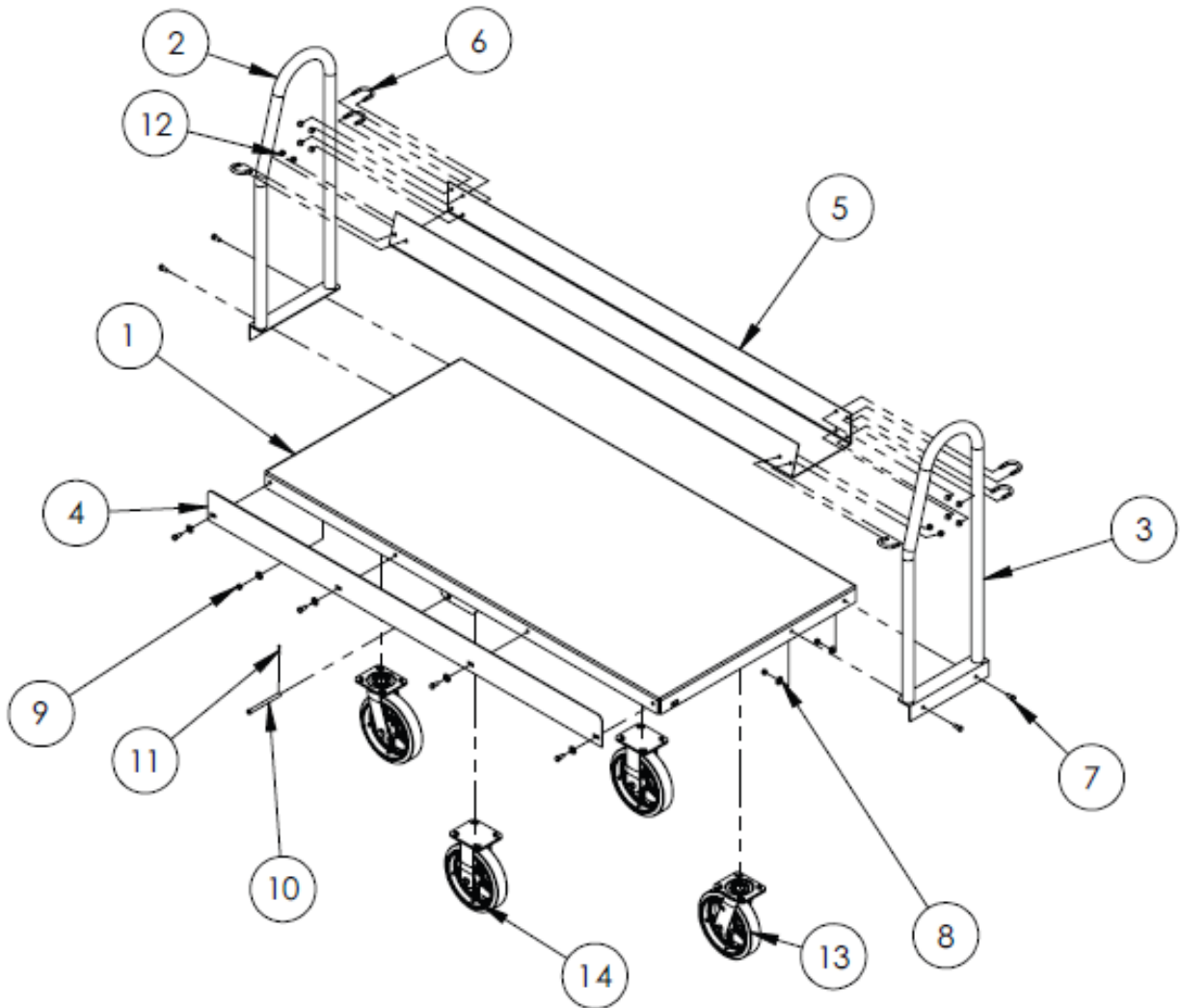

ITEM NO.	PART NO.	DESCRIPTION	QTY.
1	16-514-137	FRAME, WELDMENT	1
2	16-525-024	WELDMENT, HANDLE, LEFT	1
3	16-525-025	WELDMENT, HANDLE, RIGHT	1
4	16-024-006	GUARD, PANEL TRUCK	1
5	16-013-060	DECK, FORMED, STORAGE TRAY	1
6	16-145-016	5/16-18 U-BOLT FOR 1" PIPE	6
7	11053	5/16-18 X ¾ LG, HHCS #2 Z PLATED	8
8	33006	FLAT WASHER, ZINC PLATED, 5/16-18	12
9	36104	HEX NUT, GRADE A, ZINC PLATED, 5/16-18	8
10	99-112-006	CLEVIS PIN	4
11	65073	COTTER PIN, ZINC FINISH, 1/8 X 5/8	4
12	37709	ACORN NUT, 5/16-18	12
13	16-132-041	PRCT-T-3060-MR: CASTER, SWIVEL, 8 X 2, MOLD ON RUBBER	2
	16-132-038	PRCT-T-3060-PU: CASTER, SWIVEL, 8 X 2, POLY ON STEEL	2
14	16-132-042	PRCT-T-3060-MR: CASTER, RIGID, 8 X 2, MOLD ON RUBBER	2
	16-132-039	PRCT-T-3060-PU: CASTER, RIGID, 8 X 2, POLY ON STEEL	2

SAFETY INSTRUCTIONS

Vestil strives to identify all hazards associated with the use of our products. However, material handling is dangerous and no manual can address every risk. The most effective way to avoid injury is for the end-user to exercise sound judgment whenever using this product.

⚠ WARNING

Improper or careless operation might result in serious personal injuries or death.

- Read & understand the entire manual before assembling, using, inspecting, or servicing the cart.
- Do not exceed the capacity.
- Pull the cart. Do not push the cart.
- Do center and evenly distribute all loads applied to the cart.
- Only use this cart on level, even ground. Do not use the cart on sloped ground when it is loaded.
- Strap loads to the cart whenever necessary to maintain stability.
- Apply both caster brakes whenever the cart is parked.
- Do not modify the cart. Modifications might make the cart unsafe to use and automatically void the [LIMITED WARRANTY](#) on p. 7.
- Do not use the cart unless all labels are in place, undamaged, and easily readable from a reasonable distance. See [LABELING DIAGRAM](#) on p. 6.

ASSEMBLING THE CART

Numbers in parentheses correspond to part numbers in the bills of materials on p. 3, 4.

STEP 1: Attach casters to the underside of the frame weldment. There are 2 types of caster included in the hardware kit: 1) Rigid casters (16-132-042 OR 16-132-039); and 2) Swiveling casters (16-132-041 OR 16-132-038). The applicable exploded view indicates where each caster must be installed. Place the mounting plate of each caster inside a bulldog caster receiver (16-132-076). Secure the casters in place with a clevis pin (99-112-006) and cotter pin (65076).

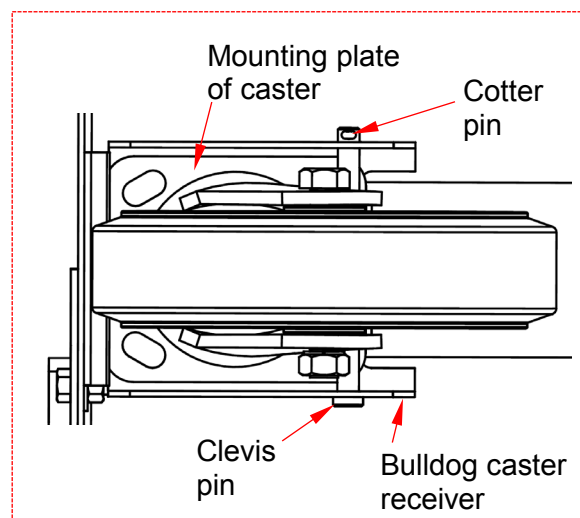
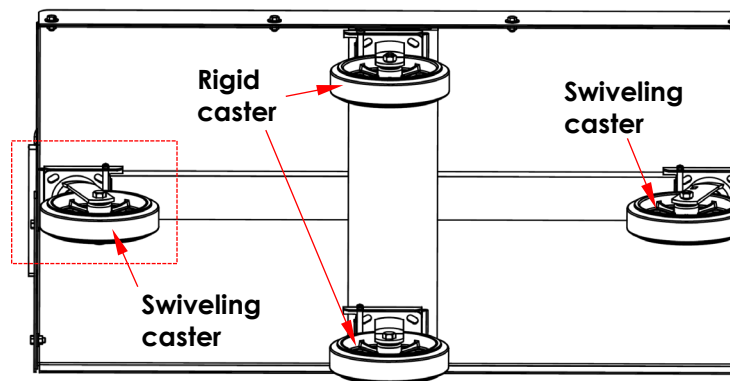

STEP 2: Fasten the storage tray to the handles with U-bolts (16-145-016) and acorn nuts (37709).

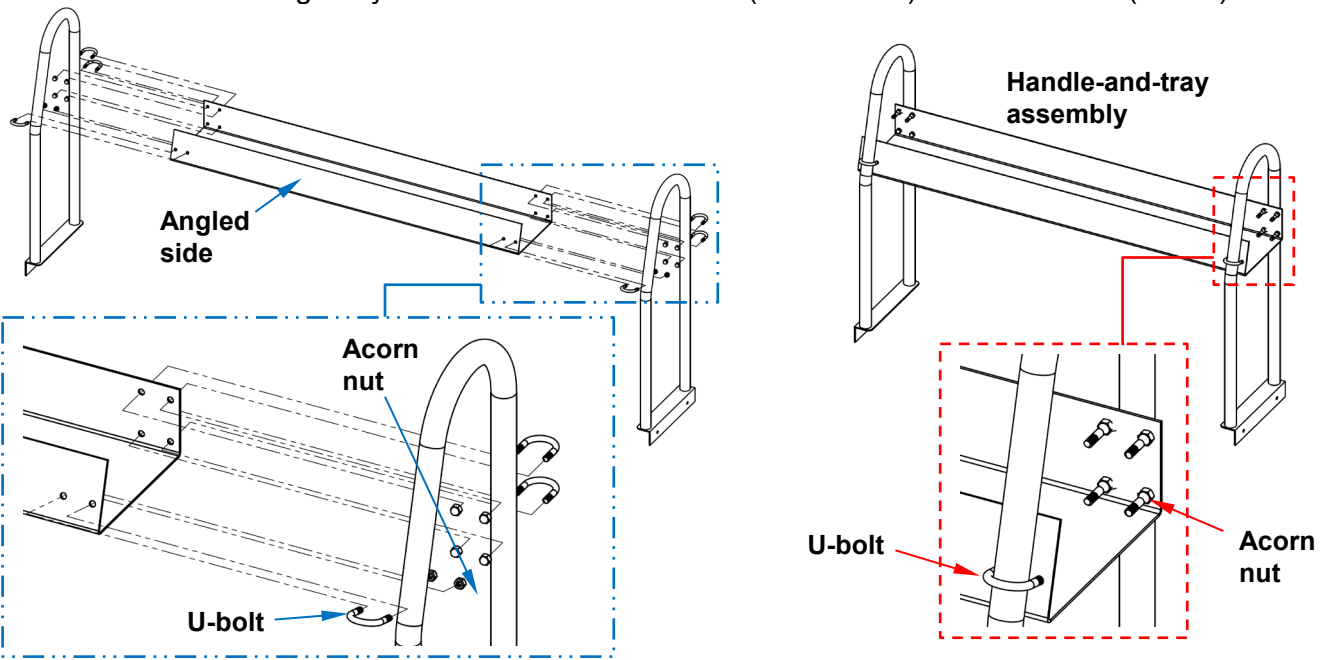

STEP 3: Attach the guard panel to the deck weldment with 5/16"-18 hardware (11053; 33006; 36104).

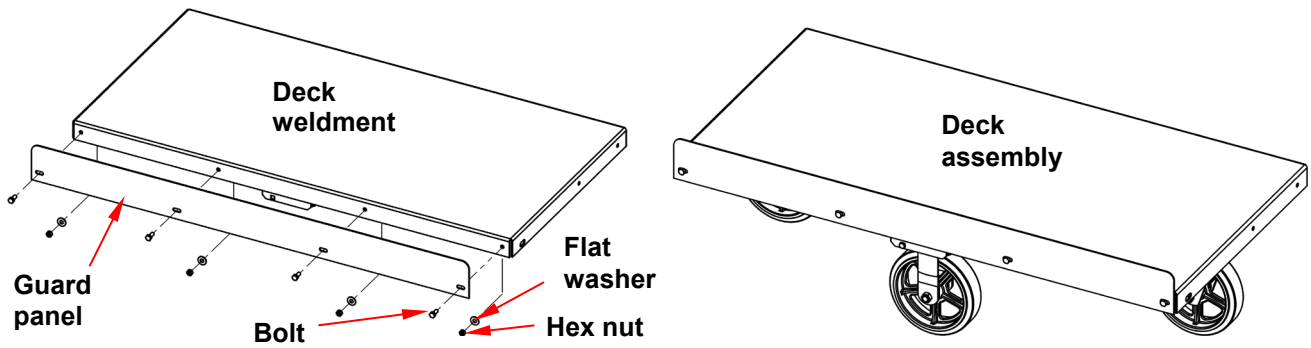

Step 4: Fasten the handle-and-tray assembly (Step 2) to the deck assembly (step 3) using 5/16"-18 hardware (11053; 33006; 36104). Align the bolt holes in the base of each handle with the bolt holes on the sides of the deck. Then, insert bolts through the bolt holes. Secure the connection with a flat washer and a hex nut.

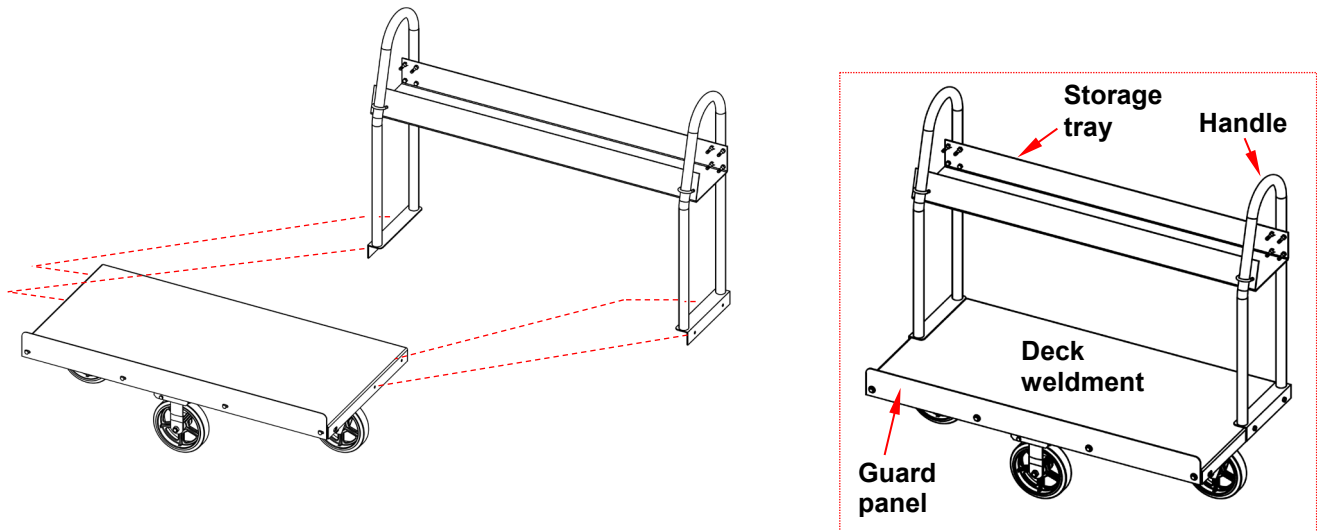

LOADING THE CART

This cart is designed to carry sheet material. Set a sheet of material on the deck with the longer dimension of the sheet resting on the deck. Carefully lay the sheet against the handles. Center the material on the deck. If necessary, adjust the location of the material so that it balances. Evenly distribute the load over the deck. Only traverse even, level ground with the cart while it is loaded. Push the cart to move it. Do not pull the cart.

RECORD OF SATISFACTORY CONDITION

Once the cart is completely assembled, and before using it for the first time, make a record of its condition. Thoroughly photograph the unit. Include close-range photographs of each label applied to the unit, all fastener attachment points (hardware fastening each handle to the deck, the storage tray to the handles, and the guard panel to the deck), the casters and bulldog caster receivers. Collect all photographs and writings in a single file. This file is a record of the unit in satisfactory condition.

INSPECTIONS & MAINTENANCE

Compare the results of each inspection to the [RECORD OF SATISFACTORY CONDITION](#) to determine whether the unit is in satisfactory condition. DO NOT use the cart unless it is in satisfactory condition. Only use manufacturer-approved replacement parts to restore the unit to satisfactory condition. **DON'T GUESS! If you have any questions about the condition of your unit, contact the TECHNICAL SERVICE department.** The phone number is provided on the cover page of this manual. Never make temporary repairs of damaged or missing parts. Purely cosmetic changes, such as chipped paint, are not changes from satisfactory condition. However, touchup paint should be applied to all areas where the finish is damaged as soon as the damage occurs because exposed metal rusts. Left unaddressed, rusting could compromise the soundness of the metal and create a safety hazard.

At least once per month:

1. Inspect all fasteners and the caster fasteners (clevis pins and cotter pins). Confirm that all hardware is in satisfactory condition. Tighten loose connections. Replace loose lock nuts and fasteners that are broken, rusted, or severely worn.
2. Inspect all 4 casters and the bulldog caster receivers. Replace a caster if its wheel is significantly worn, e.g. does not roll smoothly. Lubricate wheel pivot points as necessary to allow for quiet, uniform rotation. Inspect each caster fork, bearing, axle, wheel hub, and mounting plate for damage.
3. Examine the deck and both handles for significant wear, bends, punctures, cracked welds, and other forms of damage. The deck must be rigid and square. Handles must not wobble or lean. If a handle is damaged, contact the factory to order a replacement. If the deck is damaged, it must be replaced.

LABELING DIAGRAM

Label content and locations are subject to change so your product might not be labeled exactly as shown. Compare this diagram to the *RECORD*. If differences exist between the diagram and the *RECORD*, contact *TECHNICAL SERVICE*. Replace all labels that are damaged, missing, or not easily readable (e.g. faded). To order replacement labels, contact the technical service and parts department online at http://www.vestilmfg.com/parts_info.htm. Alternatively, you may request replacement parts and/or service by calling (260) 665-7586 and asking the operator to connect you to the Parts Department.



⚠ WARNING	⚠ ADVERTENCIA	⚠ AVERTISSEMENT
Do not operate or move with unstable loads DO NOT LOAD beyond rated capacity DISTRIBUTE LOAD EVENLY DO NOT sit or ride	No use o mueva con cargas inestables No cargue más de la capacidad tasada DISTRIBUYA LA CARGA A NIVEL NO SE SIENTE o vaya en el carro	Ne pas utiliser avec une charge instable NE PAS CHARGER au-delà du débit nominale DISTRIBUER le charge régulièrement NE PAS VOUS ASSEoir OU VOUS PROMENER sur le chariot

658, on backside of tool tray

MODEL / MODÉLO / MODÈLE _____

WEIGHT / PESO / MASS _____

CAPACITY / CAPACIDAD / CAPACITÉ _____

SERIAL / SERIE / SÉRIE _____

UNITS: 2.2 lb. = 1kg 1" (or 1in.) = 2.54cm 1153

1153, on backside of tool tray

LIMITED WARRANTY



Vestil Manufacturing Corporation (“Vestil”) warrants this product to be free of defects in material and workmanship during the warranty period. Our warranty obligation is to provide a replacement for a defective, original part covered by the warranty after we receive a proper request from the Warrantee (you) for warranty service.

Who may request service?

Only a warrantee may request service. You are a warrantee if you purchased the product from Vestil or from an authorized distributor AND Vestil has been fully paid.

Definition of “original part”?

An original part is a part used to make the product as shipped to the Warrantee.

What is a “proper request”?

A request for warranty service is proper if Vestil receives: 1) a photocopy of the Customer Invoice that displays the shipping date; AND 2) a written request for warranty service including your name and phone number. Send requests by one of the following methods:

<u>US Mail</u>	<u>Fax</u>	<u>Email</u>
Vestil Manufacturing Corporation 2999 North Wayne Street, PO Box 507 Angola, IN 46703	(260) 665-1339 <u>Phone</u> (260) 665-7586	info@vestil.com Enter “Warranty service request” in subject field.

In the written request, list the parts believed to be defective and include the address where replacements should be delivered. After Vestil receives your request for warranty service, an authorized representative will contact you to determine whether your claim is covered by the warranty. Before providing warranty service, Vestil will require you to send the entire product, or just the defective part (or parts), to its facility in Angola, IN.

What is covered under the warranty?

The warranty covers defects in the following original, dynamic parts: motors, hydraulic pumps, motor controllers, and cylinders. It also covers defects in original parts that wear under normal usage conditions (“wearing parts”), such as bearings, hoses, wheels, seals, brushes, and batteries.

How long is the warranty period?

The warranty period for original dynamic components is 90 days. For wearing parts, the warranty period is 90 days. Both warranty periods begin on the date Vestil ships the product to the Warrantee. If the product was purchased from an authorized distributor, the periods begin when the distributor ships the product. Vestil may, at its sole discretion, extend a warranty period for products shipped from authorized distributors by up to 30 days to account for shipping time.

If a defective part is covered by the warranty, what will Vestil do to correct the problem?

Vestil will provide an appropriate replacement for any *covered* part. An authorized representative of Vestil will contact you to discuss your claim.

What is not covered by the warranty?

The Warrantee (you) are responsible for paying labor costs and freight costs to return the product to Vestil for warranty service.

Events that automatically void this Limited Warranty.

- Misuse;
- Negligent assembly, installation, operation or repair;
- Installation/use in corrosive environments;
- Inadequate or improper maintenance;
- Damage sustained during shipping;
- Collisions or other accidents that damage the product;
- Unauthorized modifications: Do not modify the product IN ANY WAY without first receiving written authorization from Vestil.

Do any other warranties apply to the product?

Vestil Manufacturing Corp. makes no other express warranties. All implied warranties are disclaimed to the extent allowed by law. Any implied warranty not disclaimed is limited in scope to the terms of this Limited Warranty. Vestil makes no warranty or representation that this product complies with any state or local design, performance, or safety code or standard. Noncompliance with any such code or standard is not a defect in material or workmanship.