

# PALLET MASTER/SERVER - PMPS-60-DC

APPROX WEIGHT: 1042.13 lbs.  
DOES NOT INCLUDE WEIGHT OF POWER OR PACKAGING!!!

\*\*\* ANY ADDITIONS, DELETIONS, OR OMISSIONS MUST BE CORRECTED ON THIS DRAWING AS THIS DRAWING WILL BE CONSIDERED ALL INCLUSIVE \*\*\*  
ALL GRAPHICS PROVIDED ARE FOR REFERENCE ONLY. IF CERTAIN DIMENSIONS ARE CRITICAL PLEASE VERIFY THOSE DIMENSIONS WITH YOUR SALESPERSON

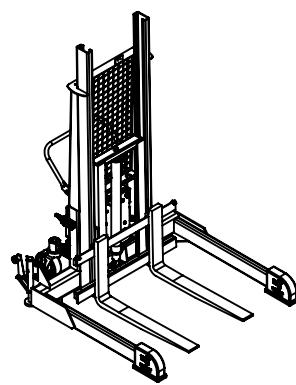
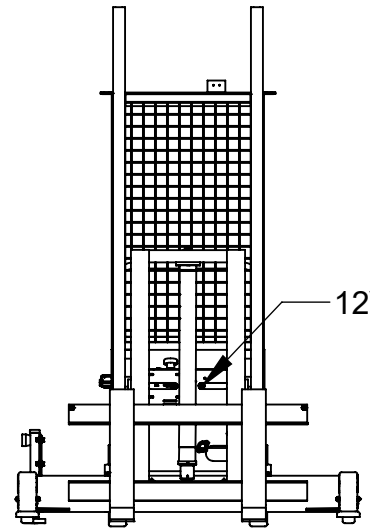
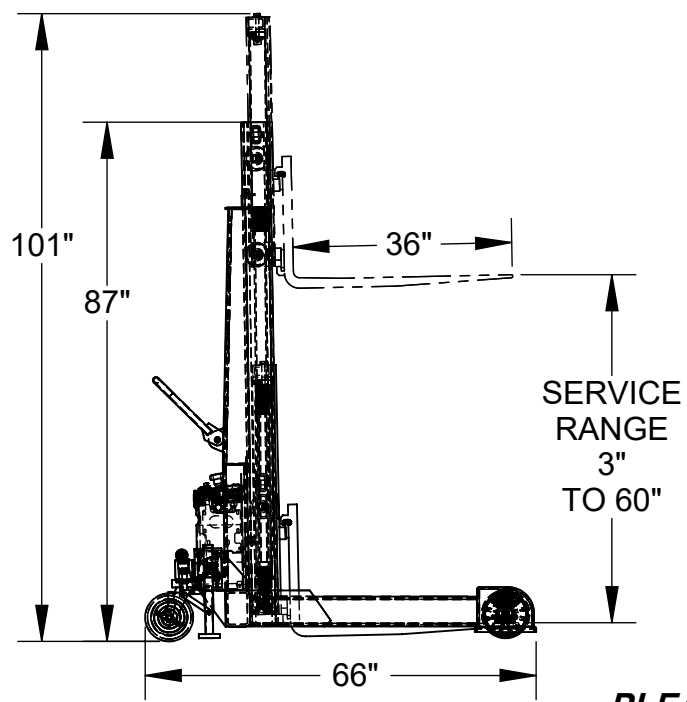
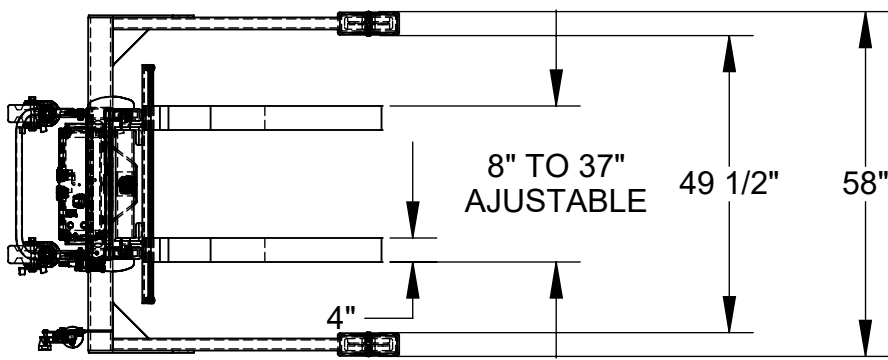

## STANDARD FEATURES

- MODEL NUMBER IS: PMPS-60-DC
- OVERALL WIDTH IS 58"
- STRADDLE INNER DIMENSION IS 49 1/2"
- OVERALL LENGTH IS 66"
- OVERALL RAISED HEIGHT IS 101"
- OVERALL LOWERED HEIGHT IS 87"
- FORK RAISED HEIGHT IS 60"
- FORK LOWERED HEIGHT IS 3"
- MAXIMUM FORK HEIGHT BEFORE CARRIAGE EXCEEDS HEIGHT OF MAST IS 42"
- FORK CAPACITY (EVENLY DISTRIBUTED) IS 4000 LBS.
- FORKS ARE 1 1/2" THICK x 4" WIDE x 36" LONG
- MAXIMUM FORK SPREAD IS 37" O.D.
- FLOOR LOCK
- 12V DC POWER UNIT
- CONTROL PENDANT W/ 8' CORD NOT SHOWN
- ALL STEEL CONSTRUCTION (ASTM A-36 MINIMUM)
- DURABLE LIQUID PAINT BLUE FINISH

## SPECIAL FEATURES

NONE

FOR INTERNAL USE ONLY PROJECT SIGN OFF	
SALES	
ENG.	
FAB.	
POWER	

DIMENSION TOLERANCE ± 1/4"

### PLEASE CIRCLE SPECIFICATIONS:

POWER	AC	DC (12V)	*AIR/OIL
MOTOR VOLTAGE	115	208	230 460
DEDICATED CIRCUIT REQUIRED			
MOTOR PHASE	SINGLE	THREE	
CONTROL	HAND	* FOOT	
~ ALL BATTERY CHARGERS ARE 115V AC ~			
BATTERY CHRG.	REMOTE	ON-BOARD	
* CHRG. INDICATOR	YES	NO	

\* AVAILABLE AT ADDITIONAL COST

**APPROVAL**

I, THE UNDERSIGNED, AGREE THAT THE PRODUCT AS REPRESENTED SATISFIES DESIGN AND DIMENSION REQUIREMENTS. I ALSO ACKNOWLEDGE MY DUTY TO CONFIRM PRODUCT AND INSTALLATION COMPLIANCE WITH ALL APPLICABLE FEDERAL, STATE AND LOCAL REGULATIONS AND STANDARDS.

**ANY MODIFIED UNITS ARE NON-RETURNABLE**

[ ] As drawn [ ] As marked

Signed: \_\_\_\_\_ Date: \_\_\_\_\_

Printed Name: \_\_\_\_\_

LEAD TIME WILL START UPON RECEIPT OF SIGNED APPROVAL DRAWING

DISTRIBUTOR'S NAME:		P.O.#
VESTIL MANUFACTURING		X
DRAWN BY: A.FORD		W.O.#
DATE: 8/3/07		X
REFERENCE: X	SCALE: 1:32	SALES: X
QUOTED LEAD TIME: X	QUOTE #	FILE NAME:
	X	15-007-021