

Magnetic Sweeper Instruction Manual

For Item No. 114024 114036

It can snap up up nails, screws, paper clips and more. Clear the collected iron parts through release handle in the sweeper.

It works very perfectly in cleaning factories aisle, shop aisles, construction sites, walkways, loading docks, parking area, etc.

To release the iron parts,
lift the releasing handle,
lift the magnetic base
as the figure shows.

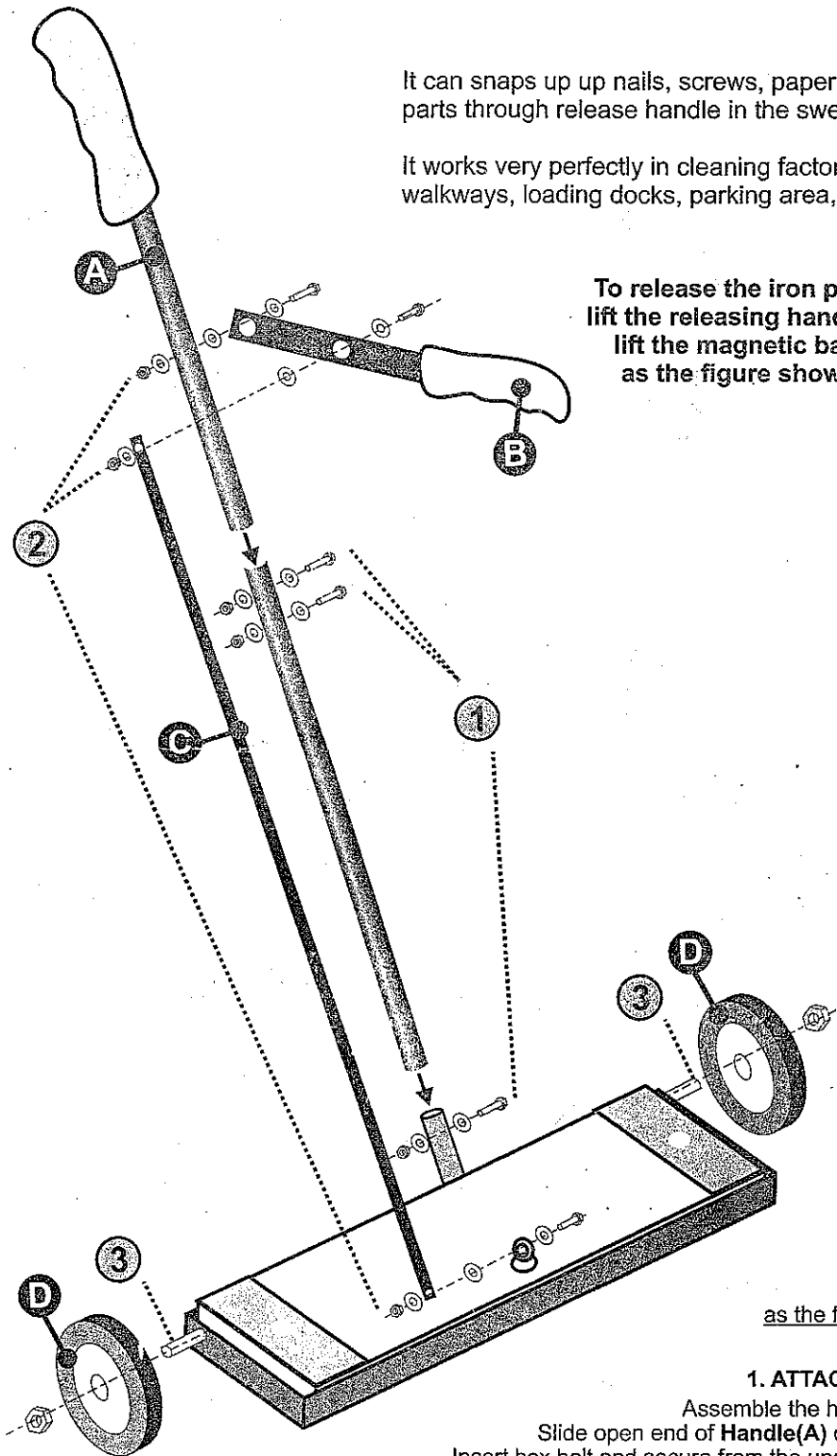
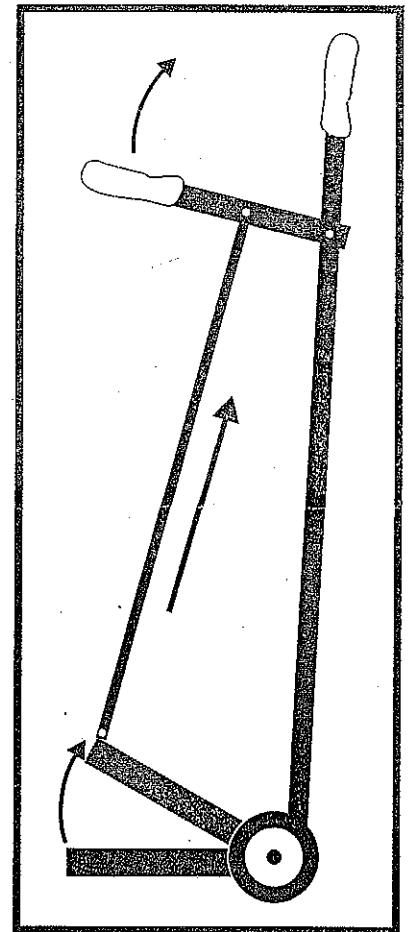

Assembly guide:

(Install the parts with supplied bolts & nuts
as the figure shows step by step as following guide)

1. ATTACH HANDLE TO MAGNET BASE (Figure 1)

Assemble the handle sections using 2 hex screws and nuts.
Slide open end of **Handle(A)** over magnet assembly stem and align holes.
Insert hex bolt and secure from the underside with a locking hex nut. Tighten firmly.

2. ATTACH RELEASE BAR (Figure 2)

Attach top of **Release Bar(C)** to pull lever by aligning holes and placing a hex bolt through a washer and into the hole **Pull Lever(B)**. Place a washer between the **Release Bar(C)** and **Pull Lever(B)**, then secure with washer and locking hex nut. For the bottom of the **Release Bar(C)**, align the **Eyebolt** hole with a washer and then place the hex bolt into **Eyebolt**. Place washer between the **Eyebolt** and both sides of the **Release Bar(C)** and secure with a locking hex nut.

3. ATTACH WHEEL (Figure 3)