

9-STEP ROLLING STEEL WAREHOUSE LADDER - LAD-9-21-P

APPROX WEIGHT: 220.3201 lbs.
DOES NOT INCLUDE WEIGHT OF POWER OR PACKAGING!!!

*** ANY ADDITIONS, DELETIONS, OR OMISSIONS MUST BE CORRECTED ON THIS DRAWING AS THIS DRAWING WILL BE CONSIDERED ALL INCLUSIVE ***

ALL GRAPHICS PROVIDED ARE FOR REFERENCE ONLY. IF CERTAIN DIMENSIONS ARE CRITICAL PLEASE VERIFY THOSE DIMENSIONS WITH YOUR SALESPERSON

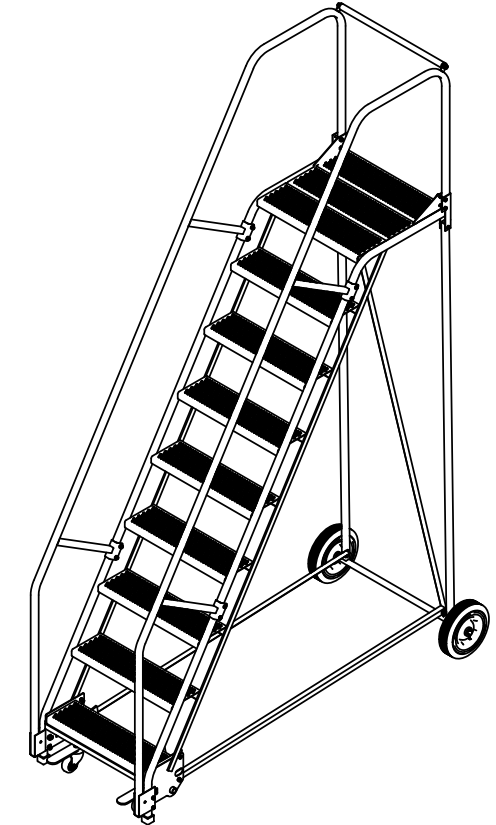
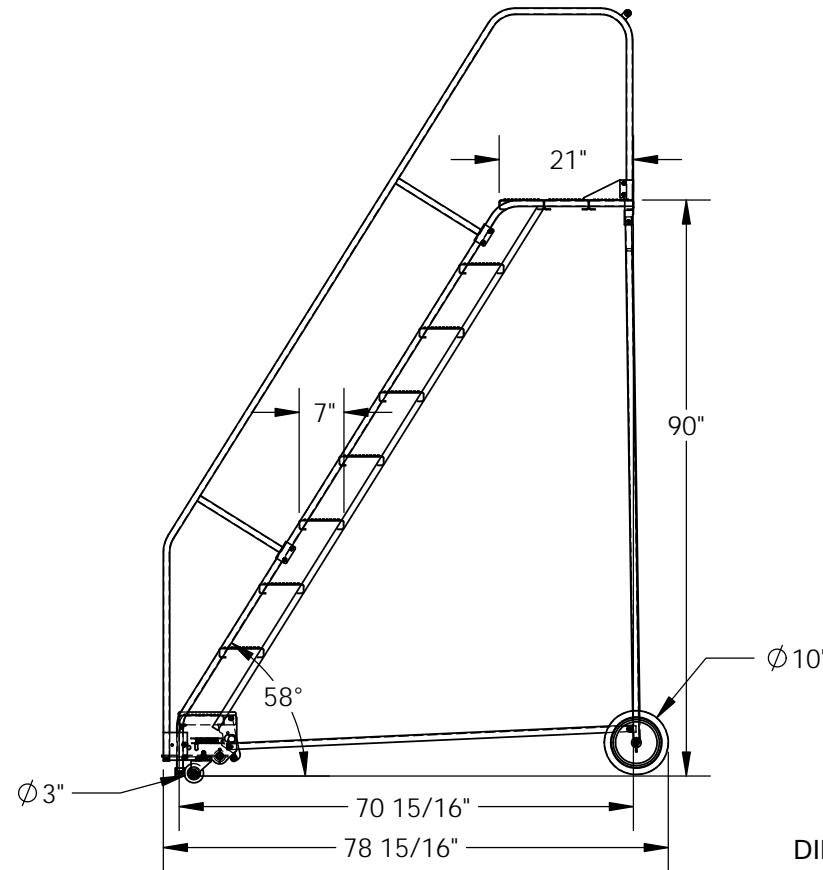
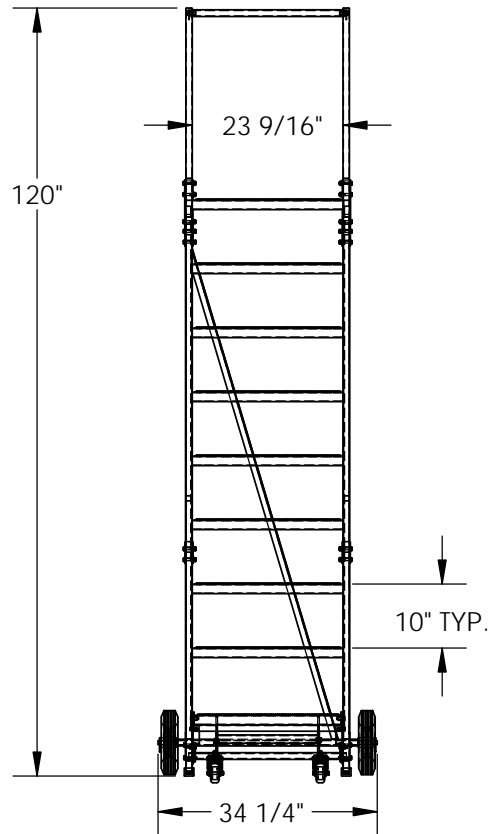

DIMENSION TOLERANCE ± 1/4"

STANDARD FEATURES

MODEL NUMBER IS LAD-9-21-P
OVERALL WIDTH IS 34 1/4"
USABLE WIDTH IS 23 9/16"
OVERALL LENGTH IS 78 15/16"
USABLE LENGTH IS 70 15/16"
OVERALL HEIGHT IS 120"
TOP STEP HEIGHT IS 90"
STEP TYPE IS PERFORATED
CLIMB ANGLE IS 58°
STEP DEPTH IS 7"
TOP STEP DEPTH IS 21"
MAX CAPACITY IS 350 LBS
WHEEL SIZE IS Ø10"
FRONT WHEEL SIZE IS Ø3"
POWDER COAT FINISH
COLOR IS BLUE, BOTTOM STEP IS YELLOW

NOTE

SOME ASSEMBLY REQUIRED
TOOL TRAY SOLD SEPARATELY
SAFETY GATE SOLD SEPARATELY

SPECIAL FEATURES

NONE

APPROVAL

I, THE UNDERSIGNED, AGREE THAT THE PRODUCT AS REPRESENTED SATISFIES DESIGN AND DIMENSION REQUIREMENTS. I ALSO ACKNOWLEDGE MY DUTY TO CONFIRM PRODUCT AND INSTALLATION COMPLIANCE WITH ALL APPLICABLE FEDERAL, STATE AND LOCAL REGULATIONS AND STANDARDS.
ALL SPECIAL UNITS ARE NON-RETURNABLE
[] As drawn [] As marked

Signed: _____ Date: _____

LEAD TIME WILL START UPON RECEIPT OF SIGNED APPROVAL DRAWING

FOR INTERNAL USE ONLY PROJECT SIGN OFF	
SALES	
ENG.	
FAB.	
POWER	

DISTRIBUTOR'S NAME:		P.O.#
VESTIL MANUFACTURING		X
DRAWN BY: B.NOTHNAGEL		DATE: 9/22/2015
REFERENCE: X		SCALE: 1:30
QUOTED LEAD TIME: X		QUOTE # X
		W.O.# X
		SALES: X
		FILE NAME: 44-007-127