

# FILLED OFFSET COUNTERBALANCE JIB BASE - JIB-CBX-36-BC

\*\*\* ANY ADDITIONS, DELETIONS, OR OMISSIONS MUST BE CORRECTED ON THIS DRAWING AS THIS DRAWING WILL BE CONSIDERED ALL INCLUSIVE \*\*\*  
 ALL GRAPHICS PROVIDED ARE FOR REFERENCE ONLY. IF CERTAIN DIMENSIONS ARE CRITICAL PLEASE VERIFY THOSE DIMENSIONS WITH YOUR SALESPERSON

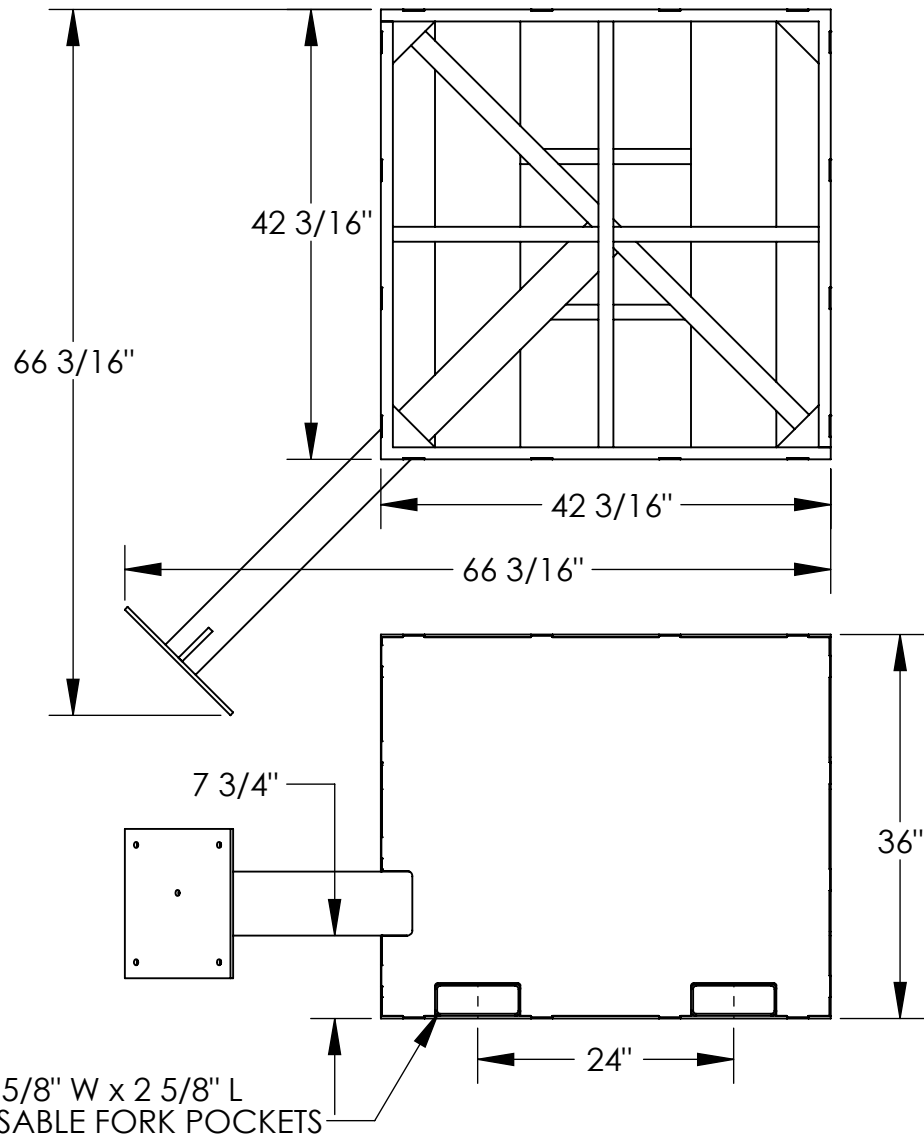

NOTE: UNIT IS FILLED WITH GRAVEL OR LIMESTONE AGGREGATE CONCRETE.

**WEIGHT FILLED WITH CONCRETE IS: 5,315 lbs. OR MORE**

**DIMENSION TOLERANCE ± 1/4"**

## STANDARD FEATURES

MODEL NUMBER IS JIB-CBX-36-BC  
 OVERALL WIDTH IS 66 3/16"  
 OVERALL LENGTH IS 66 3/16"  
 OVERALL HEIGHT IS 36"  
 USABLE FORK POCKETS: 7 5/8" X 2 5/8"  
 FORK POCKET CENTERS ARE 24"  
 DURABLE LIQUID PAINT BLUE FINISH  
 FOR USE WITH MODELS: JIB-CBX-50-10-10  
 JIB-CBX-100-8-10

## SPECIAL FEATURES

NONE

FOR INTERNAL USE ONLY PROJECT SIGN OFF	
SALES	
ENG.	
FAB.	
POWER	

<b>APPROVAL</b>	I, THE UNDERSIGNED, AGREE THAT THE PRODUCT AS REPRESENTED SATISFIES DESIGN AND DIMENSION REQUIREMENTS. I ALSO ACKNOWLEDGE MY DUTY TO CONFIRM PRODUCT AND INSTALLATION COMPLIANCE WITH ALL APPLICABLE FEDERAL, STATE AND LOCAL REGULATIONS AND STANDARDS.	
	<b>ANY MODIFIED UNITS ARE NON-RETURNABLE</b>	
	[ ] As drawn [ ] As marked	
	Signed: _____	Date: _____
Printed Name: _____		
<b>LEAD TIME WILL START UPON RECEIPT OF SIGNED APPROVAL DRAWING</b>		

DISTRIBUTOR'S NAME:		P.O.#
VESTIL MANUFACTURING		X
DRAWN BY: ND		W.O.#
DATE: 10/2/2008		X
REFERENCE: X	SCALE: 1:18	SALES: X
QUOTED LEAD TIME: X	QUOTE #	FILE NAME:
	X	28-007-240-001