

HORIZONTAL STORAGE RACK - HSR-4860

APPROX WEIGHT: 112.31 lbs.
 DOES NOT INCLUDE WEIGHT OF POWER OR PACKAGING!!!

*** ANY ADDITIONS, DELETIONS, OR OMISSIONS MUST BE CORRECTED ON THIS DRAWING AS THIS DRAWING WILL BE CONSIDERED ALL INCLUSIVE ***

ALL GRAPHICS PROVIDED ARE FOR REFERENCE ONLY. IF CERTAIN DIMENSIONS ARE CRITICAL PLEASE VERIFY THOSE DIMENSIONS WITH YOUR SALESPERSON

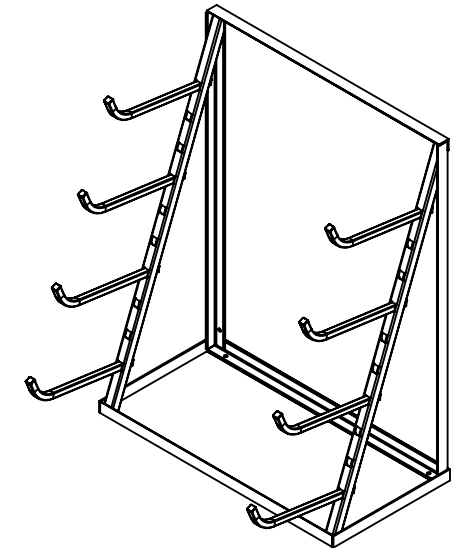
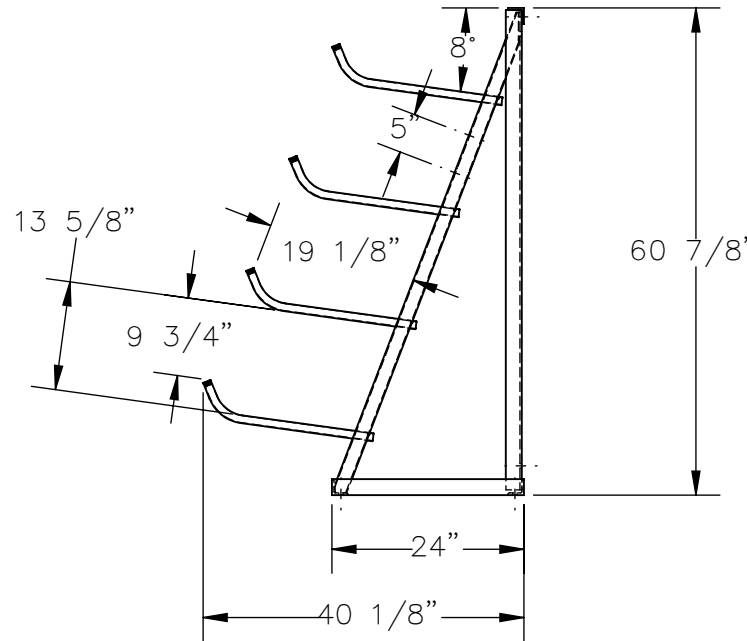
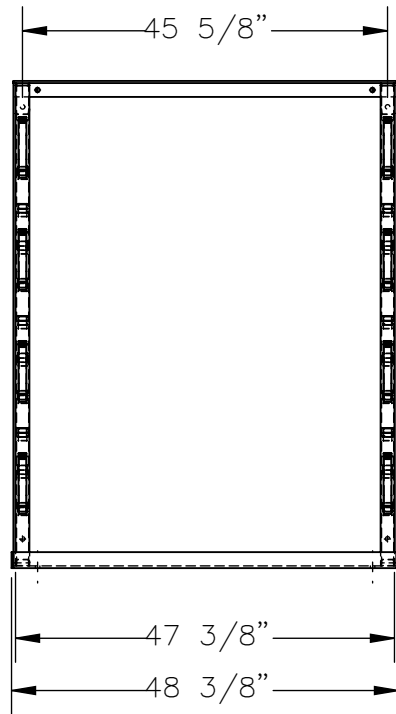

DIMENSION TOLERANCE $\pm 1/4$ "

STANDARD FEATURES

- MODEL NUMBER IS: HSR-4860
- CAPACITY IS: 250 LBS PER ARM
(2,000 LBS MAX RACK CAPACITY)
- OVERALL LENGTH IS: 40 1/8"
- USABLE ARM LENGTH IS: 19 1/8"
- ARMS MOUNT SPACING IS: 5" ON CENTER
- 10 MOUNT LOCATIONS PER SIDE (20 TOTAL)
- QUANTITY OF ARMS INCLUDED WITH RACK: 8 PCS
- OVERALL WIDTH IS: 48 3/8"
- USABLE WIDTH IS: 47 3/8"
- OVERALL HEIGHT IS: 60 7/8"
- TOUGH BAKED IN POWDER COATED BLUE FINISH
- RACK MUST BE ANCHORED TO GROUND BEFORE USE.

SPECIAL FEATURES

NONE

APPROVAL

I, THE UNDERSIGNED, AGREE THAT THE PRODUCT AS REPRESENTED SATISFIES DESIGN AND DIMENSION REQUIREMENTS. I ALSO ACKNOWLEDGE MY DUTY TO CONFIRM PRODUCT AND INSTALLATION COMPLIANCE WITH ALL APPLICABLE FEDERAL, STATE AND LOCAL REGULATIONS AND STANDARDS.
UNITS REQUIRING APPROVAL DRAWINGS OR MODIFIED ARE NON-RETURNABLE
 As drawn As marked

Signed: _____ Date: _____

Printed Name: _____

LEAD TIME WILL START UPON RECEIPT OF SIGNED APPROVAL DRAWING

DISTRIBUTOR'S NAME:		P.O.#
VESTIL MANUFACTURING		X
DRAWN BY: JGP		W.O.#
DATE: 4/7/2021		X
REFERENCE: X	SCALE: 1:24	SALES: X
QUOTED LEAD TIME: X	QUOTE #	FILE NAME:
	X	31-007-360