

FORK MOUNTED BASE - HOOK-BASE-44

APPROX WEIGHT: 104.20 lbs.
DOES NOT INCLUDE WEIGHT OF POWER OR PACKAGING!!!

*** ANY ADDITIONS, DELETIONS, OR OMISSIONS MUST BE CORRECTED ON THIS DRAWING AS THIS DRAWING WILL BE CONSIDERED ALL INCLUSIVE ***

ALL GRAPHICS PROVIDED ARE FOR REFERENCE ONLY. IF CERTAIN DIMENSIONS ARE CRITICAL PLEASE VERIFY THOSE DIMENSIONS WITH YOUR SALESPERSON

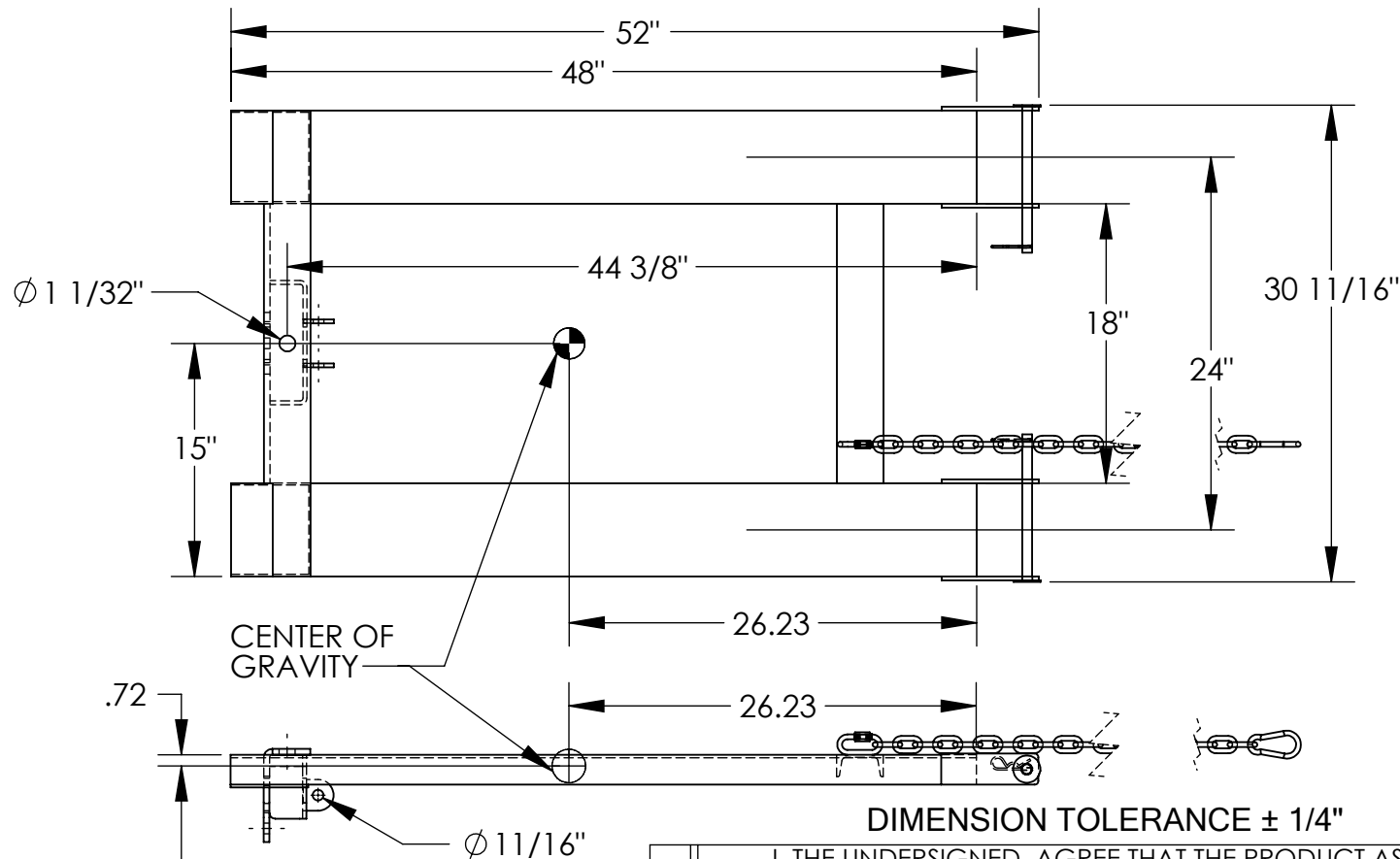
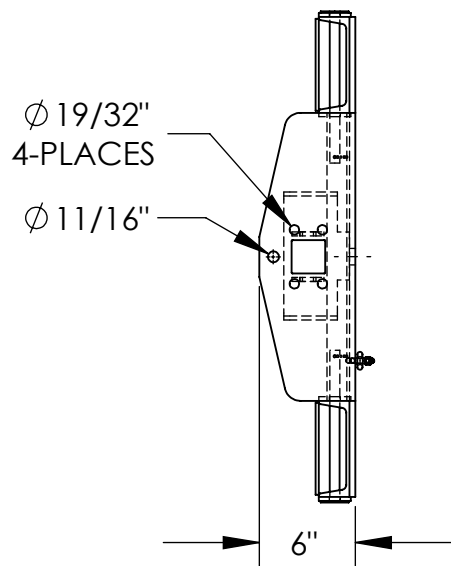

STANDARD FEATURES

- MODEL NUMBER: HOOK-BASE-44
- CAPACITY: 4,000 LBS
- OVERALL HEIGHT: 6"
- OVERALL WIDTH: 30 11/16"
- OVERALL LENGTH: 52"
- ACCOMMODATES UP TO A 5" WIDE x 2" THICK FORK
- MINIMUM FORK LENGTH: 48"
- PIN STYLE TINE LOCK
- EFFECTIVE THICKNESS IS LESS THAN 1"
- LOST LOAD = 104.20 LBS.
- TOUGH BAKED IN POWDER COATED BLUE FINISH

NEVER EXCEED LOAD CENTER RATING PER FORK TRUCK MANUFACTURER'S GUIDELINES. DO NOT USE THIS FORK TRUCK ATTACHMENT IF LOAD WILL EXCEED FORK TRUCK MANUFACTURER'S LOAD CENTER RATING.

* OSHA REQUIRES ALL FORK LIFT ATTACHMENTS TO BE APPROVED BY THE FORK TRUCK MANUFACTURER. RELABELING OF FORK TRUCK MAY BE REQUIRED DUE TO CHANGES IN LOAD CENTERS. IT IS THE RESPONSIBILITY OF THE CUSTOMER TO GET PERMISSION FROM THE FORK TRUCK MANUFACTURER FOR USE ON THEIR SPECIFIC FORK TRUCKS.

SPECIAL FEATURES

NONE

DIMENSION TOLERANCE ± 1/4"

I, THE UNDERSIGNED, AGREE THAT THE PRODUCT AS REPRESENTED SATISFIES DESIGN AND DIMENSION REQUIREMENTS. I ALSO ACKNOWLEDGE MY DUTY TO CONFIRM PRODUCT AND INSTALLATION COMPLIANCE WITH ALL APPLICABLE FEDERAL, STATE AND LOCAL REGULATIONS AND STANDARDS.

ANY MODIFIED UNITS ARE NON-RETURNABLE

As drawn As marked

Signed: _____ Date: _____

Printed Name: _____

LEAD TIME WILL START UPON RECEIPT OF SIGNED APPROVAL DRAWING

APPROVAL

FOR INTERNAL USE ONLY PROJECT SIGN OFF	
SALES	
ENG.	
FAB.	
POWER	

DISTRIBUTOR'S NAME:		P.O.#
VESTIL MANUFACTURING		X
DRAWN BY: CA	DATE: 10/22/2013	W.O.#
REFERENCE: X	SCALE: 1:12	X
QUOTED LEAD TIME: X	QUOTE #	SALES: X
	X	FILE NAME:
		08-007-150