

GATE - HBD-GATE-48

APPROX WEIGHT: 344.02 lbs.
 DOES NOT INCLUDE WEIGHT OF POWER OR PACKAGING!!!

*** ANY ADDITIONS, DELETIONS, OR OMISSIONS MUST BE CORRECTED ON THIS DRAWING AS THIS DRAWING WILL BE CONSIDERED ALL INCLUSIVE ***
 ALL GRAPHICS PROVIDED ARE FOR REFERENCE ONLY. IF CERTAIN DIMENSIONS ARE CRITICAL PLEASE VERIFY THOSE DIMENSIONS WITH YOUR SALESPERSON

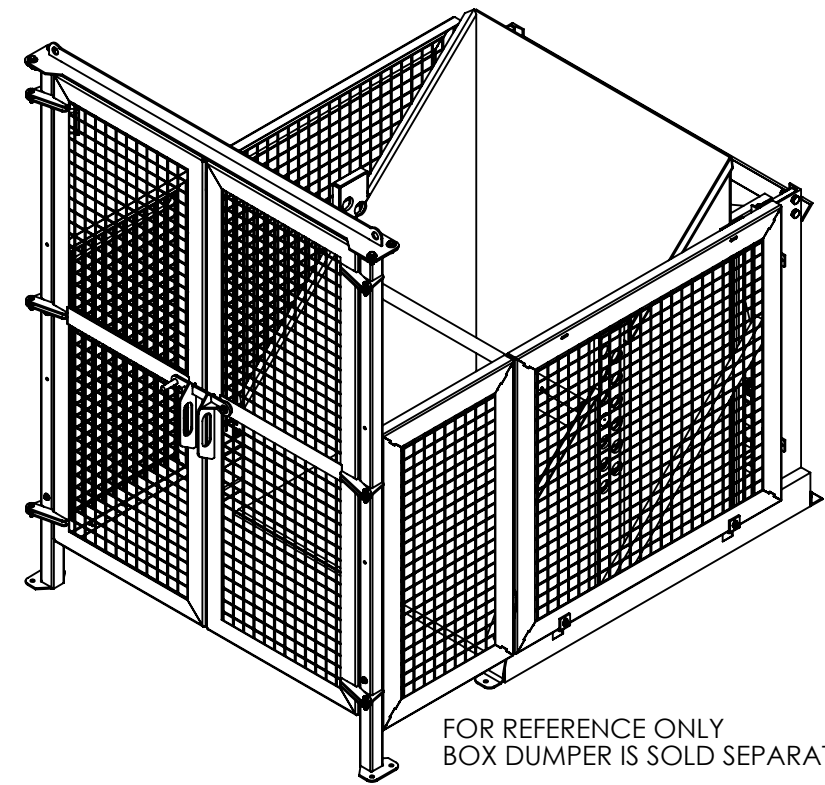
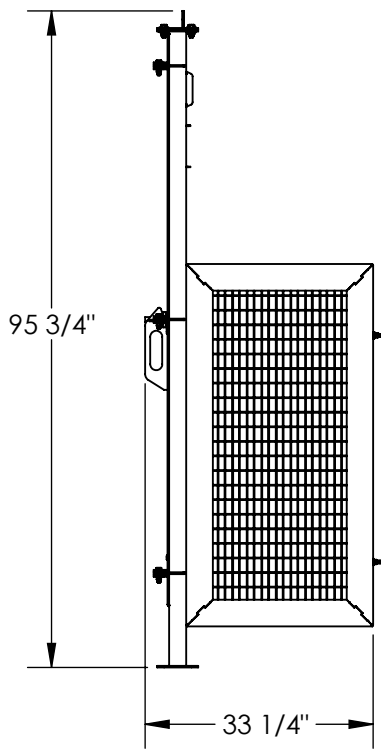
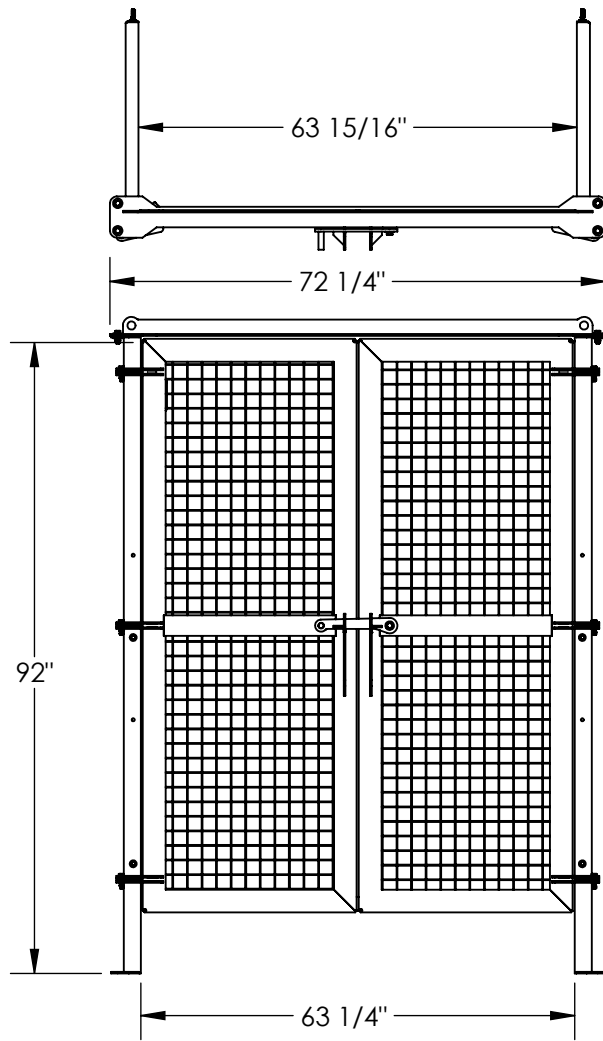

FOR REFERENCE ONLY
 BOX DUMPER IS SOLD SEPARATELY

DIMENSION TOLERANCE ± 1/4"

STANDARD FEATURES

- MODEL NUMBER IS HBD-GATE-48
- OVERALL WIDTH IS 72 1/4"
- USABLE WIDTH IS 63 1/4"
- OVERALL LENGTH IS 33 1/4"
- USABLE HEIGHT IS 92"
- OVERALL HEIGHT IS 95 3/4"
- USED ON HBD-X-48
- GATE WILL INCLUDE NON-CONTACT MAGNETIC INTERLOCK SWITCH
- UNIT WILL NOT OPERATE WHEN GATE IS OPEN
- GUARDS AND GATE TOUGH BAKED IN POWDER COAT YELLOW FINISH

SPECIAL FEATURES

NONE

APPROVAL

I, THE UNDERSIGNED, AGREE THAT THE PRODUCT AS REPRESENTED SATISFIES DESIGN AND DIMENSION REQUIREMENTS. I ALSO ACKNOWLEDGE MY DUTY TO CONFIRM PRODUCT AND INSTALLATION COMPLIANCE WITH ALL APPLICABLE FEDERAL, STATE AND LOCAL REGULATIONS AND STANDARDS.

ANY MODIFIED UNITS ARE NON-RETURNABLE

[] As drawn [] As marked

Signed: _____ Date: _____

Printed Name: _____

LEAD TIME WILL START UPON RECEIPT OF SIGNED APPROVAL DRAWING

FOR INTERNAL USE ONLY PROJECT SIGN OFF	
SALES	
ENG.	
FAB.	
POWER	

DISTRIBUTOR'S NAME:		P.O.#
VESTIL MANUFACTURING		X
DRAWN BY: CA		W.O.#
DATE: 09/29/2016		X
REFERENCE: X	SCALE: 1:28	SALES: X
QUOTED LEAD TIME: X	QUOTE #	FILE NAME:
	X	34-007-042