

# FORK MOUNTED POLY DRUM HANDLER - FPDL-11-H

APPROX WEIGHT: 166.23 lbs.  
 DOES NOT INCLUDE WEIGHT OF POWER OR PACKAGING!!!

\*\*\* ANY ADDITIONS, DELETIONS, OR OMISSIONS MUST BE CORRECTED ON THIS DRAWING AS THIS DRAWING WILL BE CONSIDERED ALL INCLUSIVE \*\*\*

ALL GRAPHICS PROVIDED ARE FOR REFERENCE ONLY. IF CERTAIN DIMENSIONS ARE CRITICAL PLEASE VERIFY THOSE DIMENSIONS WITH YOUR SALESPERSON

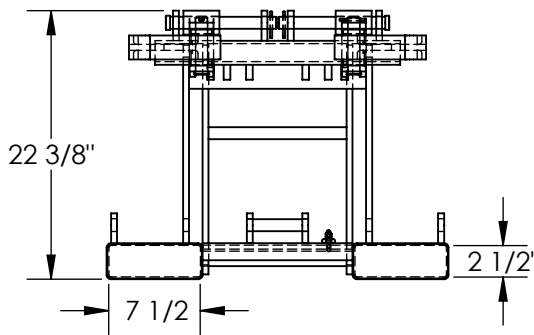
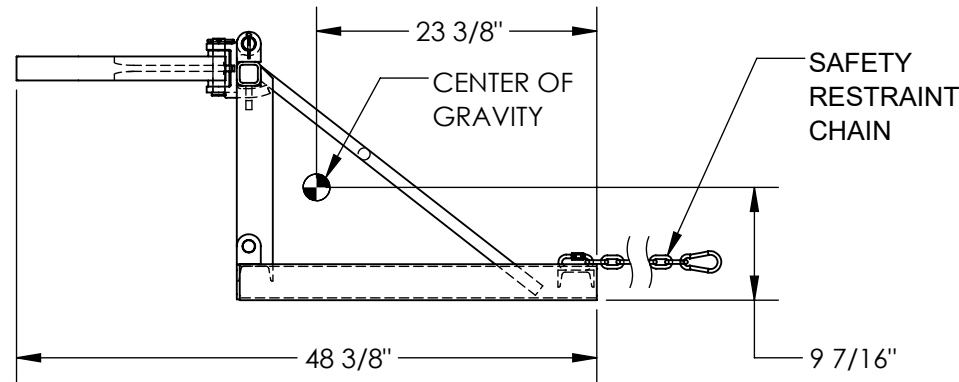
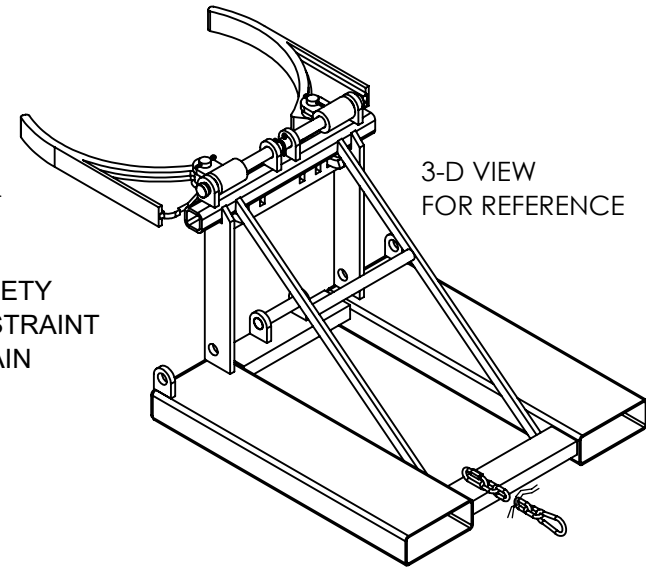
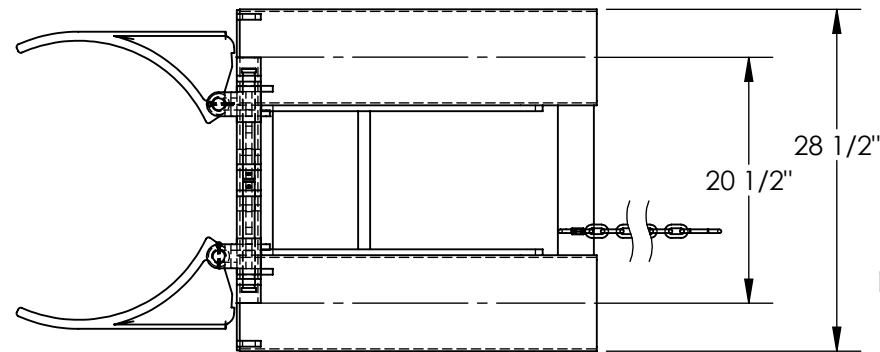

## STANDARD FEATURES

- MODEL NUMBER IS FPDL-11-H
- CAPACITY IS 1,100 LBS. (ONE DRUM)
- OVERALL WIDTH IS 28 1/2"
- OVERALL LENGTH IS 48 3/8"
- OVERALL HEIGHT IS 22 3/8"
- TOP GRIP HANDLER FOR USE WITH 30 AND 55 GALLON PLASTIC CLOSED HEAD DRUMS
- TOP LIP MUST BE STRONG ENOUGH TO SUPPORT THE WEIGHT OF THE DRUM
- FOR USE WITH TOP LIP AT LEAST 3/16" HIGH
- WILL ALSO WORK WITH STEEL AND FIBER DRUMS
- INCLUDES SAFETY RESTRAINT CHAIN TO SECURE UNIT TO FORK TRUCK
- WELDED STEEL CONSTRUCTION
- TOUGH BAKED IN POWDER COATED BLUE AND YELLOW FINISH
- USABLE FORK POCKETS ARE 7 1/2" W X 2 1/2" H
- FORK POCKETS ARE ON 20 1/2" CENTERS
- LOST LOAD IS 170 LBS (APPROX)
- EFFECTIVE THICKNESS IS FORK LENGTH MINUS 29 3/4"

NEVER EXCEED LOAD CENTER RATING PER FORK TRUCK MANUFACTURER'S GUIDELINES. DO NOT USE THIS FORK TRUCK ATTACHEMENT IF LOAD WILL EXCEED FORK TRUCK MANUFACTURER'S LOAD CENTER RATING.

## SPECIAL FEATURES

NONE

DIMENSION TOLERANCE ± 1/4"

<b>APPROVAL</b>	I, THE UNDERSIGNED, AGREE THAT THE PRODUCT AS REPRESENTED SATISFIES DESIGN AND DIMENSION REQUIREMENTS. I ALSO ACKNOWLEDGE MY DUTY TO CONFIRM PRODUCT AND INSTALLATION COMPLIANCE WITH ALL APPLICABLE FEDERAL, STATE AND LOCAL REGULATIONS AND STANDARDS.	
	<b>ANY MODIFIED UNITS ARE NON-RETURNABLE</b>	
	[ ] As drawn      [ ] As marked	
Signed: _____	Date: _____	
Printed Name: _____		
<b>LEAD TIME WILL START UPON RECEIPT OF SIGNED APPROVAL DRAWING</b>		

FOR INTERNAL USE ONLY PROJECT SIGN OFF	
SALES	
ENG.	
FAB.	
POWER	

DISTRIBUTOR'S NAME:		P.O.#
<b>VESTIL MANUFACTURING</b>		X
DRAWN BY: MTS		W.O.#
DATE: 11/21/2017		X
REFERENCE: X	SCALE: 1:16	SALES: X
QUOTED LEAD TIME: X	QUOTE #	FILE NAME:
	X	40-007-007