

FIXED STEEL GANTRY CRANE - KNOCKDOWN - FHSN-4-20

APPROX WEIGHT: 1028.41 lbs.
DOES NOT INCLUDE WEIGHT OF POWER OR PACKAGING!!!

*** ANY ADDITIONS, DELETIONS, OR OMISSIONS MUST BE CORRECTED ON THIS DRAWING AS THIS DRAWING WILL BE CONSIDERED ALL INCLUSIVE ***

ALL GRAPHICS PROVIDED ARE FOR REFERENCE ONLY. IF CERTAIN DIMENSIONS ARE CRITICAL PLEASE VERIFY THOSE DIMENSIONS WITH YOUR SALESPERSON

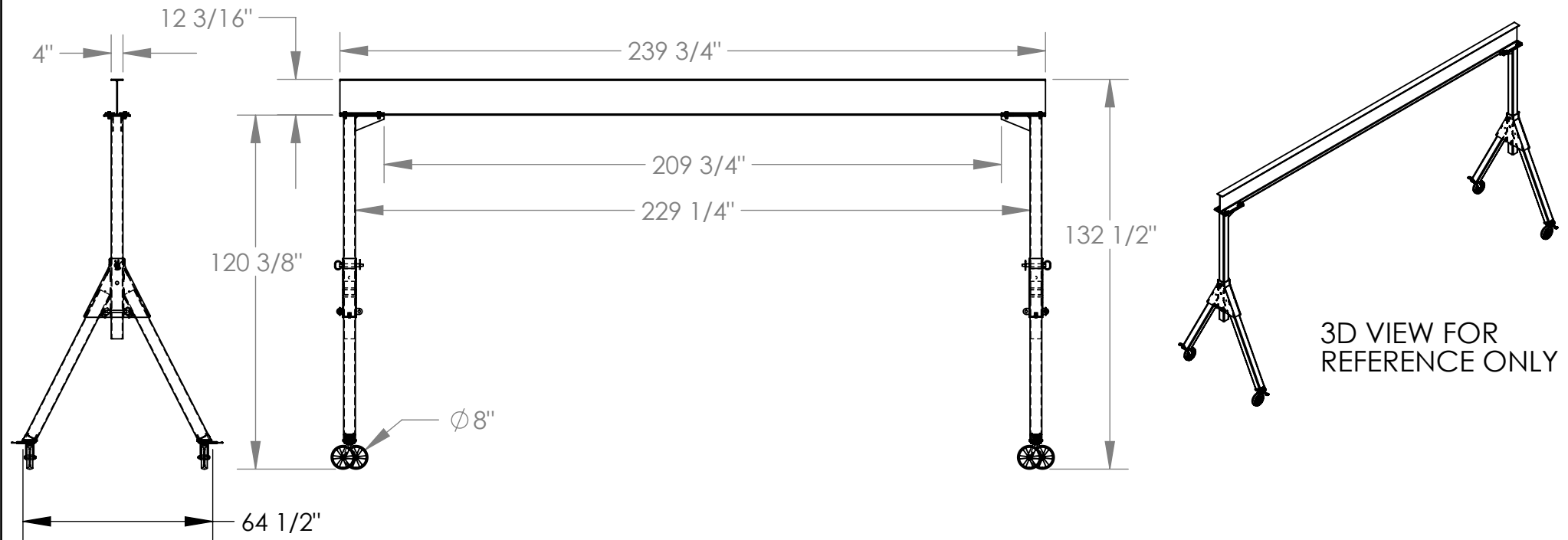

STANDARD FEATURES

MODEL NUMBER IS FHSN-4-20
CAPACITY IS 4,000 LBS.
BASE WIDTH IS 64 1/2"
OVERALL HEIGHT IS 132 1/2"
I-BEAM HEIGHT IS 12 3/16"
I-BEAM FLANGE WIDTH IS 4"
OVERALL I-BEAM LENGTH IS 239 3/4"
USABLE I-BEAM LENGTH IS 209 3/4"
UNDER I-BEAM HEIGHT IS 120 3/8"
CASTERS: (4) $\phi 8"$ X 2" WIDE GLASS FILLED NYLON SWIVEL CASTERS WITH FOUR LOCKING POSITIONS

SPECIAL FEATURES

NONE

DIMENSION TOLERANCE $\pm 1/4"$

I, THE UNDERSIGNED, AGREE THAT THE PRODUCT AS REPRESENTED SATISFIES DESIGN AND DIMENSION REQUIREMENTS. I ALSO ACKNOWLEDGE MY DUTY TO CONFIRM PRODUCT AND INSTALLATION COMPLIANCE WITH ALL APPLICABLE FEDERAL, STATE AND LOCAL REGULATIONS AND STANDARDS.

ANY MODIFIED UNITS ARE NON-RETURNABLE

As drawn As marked

Signed: _____ Date: _____

Printed Name: _____

LEAD TIME WILL START UPON RECEIPT OF SIGNED APPROVAL DRAWING

APPROVAL

FOR INTERNAL USE ONLY
PROJECT SIGN OFF

SALES	
ENG.	
FAB.	
POWER	

DISTRIBUTOR'S NAME:		P.O.#
VESTIL MANUFACTURING		X
DRAWN BY: MTS		DATE: 02/27/15
REFERENCE: X		SCALE: 1:50
QUOTED LEAD TIME: X		QUOTE #
		X
		FILE NAME:
		28-007-382