

MANUAL ADJUSTABLE ERGONOMIC WORK BENCH- EWB-6030

APPROX WEIGHT: 316 lbs.
DOES NOT INCLUDE WEIGHT OF POWER OR PACKAGING!!!

*** ANY ADDITIONS, DELETIONS, OR OMISSIONS MUST BE CORRECTED ON THIS DRAWING AS THIS DRAWING WILL BE CONSIDERED ALL INCLUSIVE ***
ALL GRAPHICS PROVIDED ARE FOR REFERENCE ONLY. IF CERTAIN DIMENSIONS ARE CRITICAL PLEASE VERIFY THOSE DIMENSIONS WITH YOUR SALESPERSON

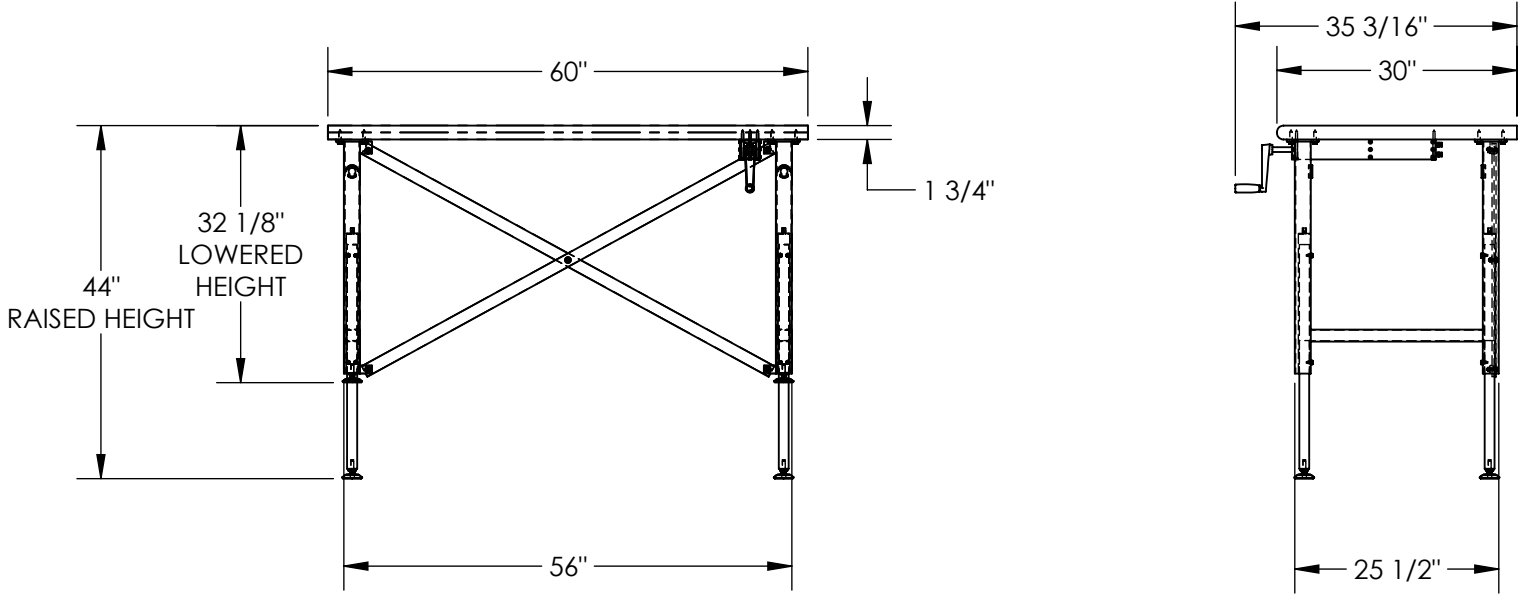

STANDARD FEATURES

- MODEL NUMBER IS EWB-6030
- OVERALL WIDTH IS 35 3/16"
- USABLE WIDTH IS 30"
- OVERALL LENGTH IS 60"
- USABLE LENGTH IS 60"
- MAX RAISED HEIGHT IS 44"
- MAX LOWERED HEIGHT IS 32 1/8"
- MAX UNIFORM CAPACITY IS 750 LBS
- FOLD AWAY CRANK HANDLE FOR MANUAL OPERATION
- HYDRAULIC SYSTEM RAISES PLATFORM EVENLY
- PLATFORM IS A MAPLE BENCH TOP W/ CATALYZED LACQUER FINISH
- LEGS ARE TOUGH BAKED IN POWDER COATED BLUE FINISH

SPECIAL FEATURES

NONE

DIMENSION TOLERANCE ± 1/4"

I, THE UNDERSIGNED, AGREE THAT THE PRODUCT AS REPRESENTED SATISFIES DESIGN AND DIMENSION REQUIREMENTS. I ALSO ACKNOWLEDGE MY DUTY TO CONFIRM PRODUCT AND INSTALLATION COMPLIANCE WITH ALL APPLICABLE FEDERAL, STATE AND LOCAL REGULATIONS AND STANDARDS.

ANY MODIFIED UNITS ARE NON-RETURNABLE

[] As drawn [] As marked

Signed: _____ Date: _____

Printed Name: _____

LEAD TIME WILL START UPON RECEIPT OF SIGNED APPROVAL DRAWING

DISTRIBUTOR'S NAME:		P.O.#
VESTIL MANUFACTURING		X
DRAWN BY: DEY		DATE: 9/5/12
REFERENCE: X		SCALE: 1:24
QUOTED LEAD TIME: X		QUOTE # X
		W.O.#
		X
		SALES: X
		FILE NAME:
		43-007-001

FOR INTERNAL USE ONLY PROJECT SIGN OFF	
SALES	
ENG.	
FAB.	
POWER	