



## VESTIL MANUFACTURING CORP.

2999 North Wayne Street, P.O. Box 507, Angola, IN 46703

Telephone: (260) 665-7586 -or- Toll Free (800) 348-0868

Fax: (260) 665-1339

www.vestilmfg.com e-mail: [sales@vestil.com](mailto:sales@vestil.com)

# EPT-SERIES ELECTRIC PALLET TRUCKS

## OPERATION AND MAINTENANCE MANUAL



### **Receiving instructions:**

After delivery, IMMEDIATELY remove the packaging from the product in a manner that preserves the packaging and maintains the orientation of the product in the packaging; then inspect the product closely to determine whether it sustained damage during transport. **If damage is discovered during the inspection, immediately record a complete description of the damage on the bill of lading.** If the product is undamaged, discard the packaging.

### **NOTES:**

- 1) Compliance with laws, regulations, codes, and non-voluntary standards enforced in the location where the product is *used* is exclusively the responsibility of the owner/end-user.
- 2) VESTIL is **not liable** for any injury or property damage that occurs as a consequence of failing to apply either:
  - a) Instructions in this manual; or b) Information provided on labels affixed to the product. Neither is Vestil responsible for *any* consequential damages sustained as a result of failing to exercise sound judgment while assembling, installing, using or maintaining this product.

| <b><u>TABLE OF CONTENTS</u></b>                    | <b><u>PAGE</u></b> | <b><u>TABLE OF FIGURES</u></b>                      | <b><u>PAGE</u></b> |
|--|--------------------|---|--------------------|
| Safety Principles                                  | 2                  | Fig. 1 EPT-45 Main Housings & Supporting Structure  | 5                  |
| Product Introduction                               | 2                  | Fig. 2 Removable Battery Box & Components           | 5                  |
| Safety Guidelines                                  | 3                  | Fig. 3 EPT-45 Cylinder & Fuse Panel                 | 6                  |
| Removing EPT from Pallet                           | 3 - 4              | Fig. 4 EPT-45 Fork & Carriage Assemblies            | 7                  |
| Use, 1 <sup>st</sup> Inspection, & Functions Tests | 11                 | FIG. 5 EPT-45 Control Handle Assembly               | 8                  |
| Operation  | 11-12              | FIG. 6 EPT-45 Drive Wheel Assembly                  | 9                  |
| Lifting & Transporting Loads                       | 12                 | Fig. 7 Function Controls, Gauges, & Safety Features | 10                 |
| Batteries & Charger                                | 12-13              |   |                    |
| Troubleshooting                                    | 14-18              |   |                    |
|  |                    | Maintenance & Inspections                           | 19-20              |
|  |                    | Markings  | 21                 |

## PRODUCT INTRODUCTION



Thank you for purchasing an electric pallet truck (“EPT,” “pallet truck,” “truck,” or “unit”) offered by Vestil Manufacturing Corporation (“Vestil”). Our EPT’s are durable, high-quality products that combine safety features and low-maintenance mechanisms. Despite the product’s relatively simple mechanics, all personnel must familiarize themselves with the safe operation instructions provided in this manual.

Specifications for each of the 4 models appear in the table below:

| <b>MODEL</b> | <b>Net Wt.<br/>(lbs.)</b> | <b>Fork Size<br/>(W x L) in inches</b> | <b>Service<br/>Range (in.)</b> | <b>Capacity<br/>(lbs.)</b> | <b>Overall Size<br/>(W X L x H) in inches</b> |
|--------------|---------------------------|--|--------------------------------|----------------------------|---|
| EPT-2048-45  | 990                       | 20in. x 48in.                          | 3.4 to 8                       | 4,500                      | 30x 78.5 x 49                                 |
| EPT-2748-45  | 1012                      | 27in. x 48in.                          | 3.4 to 8                       | 4,500                      | 30x 78.5 x 49                                 |

Vestil Manufacturing Corp. created this manual to acquaint owners and users of our electric pallet trucks with safe operation and maintenance procedures. **Employers are responsible for instructing employees to use the product properly. Employees and any other persons, who might foreseeably use, repair, or perform maintenance on the EPT must read and understand every instruction BEFORE using the device. Cart operators should have access to the manual at all times and should review the directions before each use. Contact Vestil for answers to any question you have after reading the entire manual.**

Although Vestil diligently strives to identify foreseeable hazardous situations, this manual cannot address every conceivable danger. The end-user is ultimately responsible for exercising sound judgment at all times.

## SAFETY PRINCIPLES

We offer four types of electric pallet truck (EPT): two 3,000 pound (~1364kg) capacity models, the EPT-2047-30 and 2547-30, and two 4,500 pound (~2045kg) capacity models, the EPT-2048-45 and 2748-45. Each unit conforms to the generalized specifications disclosed in this manual and fulfills our demanding standards for quality, safety and durability.

Vestil Manufacturing Corp. recognizes the critical importance of workplace safety. Each person who **might** participate in operation or maintenance of the product must read this manual. **Read the entire manual and fully understand the directions BEFORE using or performing maintenance on the cart. If you do not understand an instruction, contact Vestil for clarification. Failure to adhere to the directions in this manual might lead to serious personal injury or even death.**

Vestil is **not liable** for any injury or property damage that occurs as a consequence of failing to apply the safe operation and maintenance procedures explained in this manual or that appear on labels affixed to the product. Furthermore, failure to exercise good judgment and common sense may result in property damage, serious personal injury, or death, and also are **not the responsibility of Vestil**.

This manual applies the hazard identification methods suggested for instruction manuals by the American National Standards Institute (ANSI). In accordance with ANSI guidelines for hazard identification language, this manual classifies personal injury risks and situations that could lead to property damage with SIGNAL WORDS. These signal words announce an associated safety message. The reader must understand that the signal word chosen indicates the seriousness of that hazard according to the following convention:

**⚠ DANGER** Identifies a hazardous situation which, if not avoided, WILL result in DEATH or SERIOUS INJURY. Use of this signal word is limited to the most extreme situations.

**⚠ WARNING** Identifies a hazardous situation which, if not avoided, COULD result in DEATH or SERIOUS INJURY.

**⚠ CAUTION** Indicates a hazardous situation which, if not avoided, COULD result in MINOR or MODERATE injury.

**NOTICE** Identifies practices not related to personal injury, such as operation that could damage the cart. No safety alert symbol (equilateral triangle enclosing an exclamation point) accompanies this signal word.

## SAFETY GUIDELINES

**Failure to read and understand the instructions included in this manual before using or servicing the pallet truck constitutes misuse of the product. Study the entire manual before you use the truck for the first time and before each subsequent use.** Read the manual to refresh your understanding of the safe use and maintenance procedures on p. 50-51. If questions remain after you finish reading the manual, contact Vestil for answers. DO NOT attempt to resolve any problem with the truck unless you are certain that it will be safe to use afterwards.

### **⚠ DANGER**

To decrease the risk of electrocution:

- DO NOT *contact* or *operate* the pallet truck *close to* electrified wires or other sources of electricity;
- Before operating the EPT, always inspect the area where you will use it.

### **⚠ WARNING**

Improper use might result in serious personal injuries to the operator and/or bystanders. To minimize the possibility of injury, ALL persons who might operate, perform maintenance on, or service the EPT must read, understand and apply the following instructions:

- DO NOT operate the EPT unless and until you are:
  1. Trained to use the machine; AND
  2. Certified as a trained operator by your employer in accordance with U.S. OSHA regulations (29 CFR §1910.178) and any standards incorporated by reference (e.g. ANSI/ITSDF B56.1-2005).
- **DO NOT attempt to lift or transport loads that exceed the rated capacity.**
- Inspect the machine before each use; DO NOT use the EPT unless it is in normal condition. Normal operating condition exists if the EPT passes the inspection and functions tests described under the heading, "Inspect the EPT & Perform a Functions Tests" on p. 20.
- DO NOT use the unit until you read and understand the entire owner's manual. Review the manual before each use AND before performing maintenance on the device.
- DO NOT use the EPT if the load-supporting elements sustain any structural damage. Structural elements include, but are not limited to, the forks, carriage, and wheels. If structural damage is present, immediately tag the unit "Out of Service" and inform maintenance personnel of the problem.
- DO NOT use the EPT if it makes unusual noises during operation.
- DO NOT allow people to ride on the pallet truck. Only the operator of an EPT equipped with a properly installed rider platform (EPT
- DO NOT attempt to lift an unevenly distributed load. Always center and evenly distribute the load on the forks.
- DO NOT operate the EPT on grades exceeding 6%.
- DO NOT leave the EPT unattended while it supports a load. Always fully lower the forks, and then completely disengage the skid or pallet. Complete the parking / storing procedure described in "Storing the EPT" on p. 22.
- DO NOT modify the pallet truck without first receiving written authorization from Vestil. Unauthorized modifications may make the EPT unsafe to use.

### **NOTICE**

To maximize the service life of the EPT and to prevent damage:

- Always store the machine in a secure, dry location where it will not interfere with traffic or other activities.
- Maintain the product as suggested in "Maintenance & Inspections" on p. 49-50.

### **REMOVING THE PALLET TRUCK FROM THE SHIPPING PALLET:**

The pallet truck is shipped in ready-to-use condition. However, it must first be removed from the shipping pallet before it can be used for the first time.

### **⚠ WARNING**

DO NOT attempt to drive the pallet truck off of the pallet; it might tip over and cause bodily injuries or property damage. To minimize the risk of injury to yourself or other persons, perform the following steps to remove the machine from the shipping pallet:

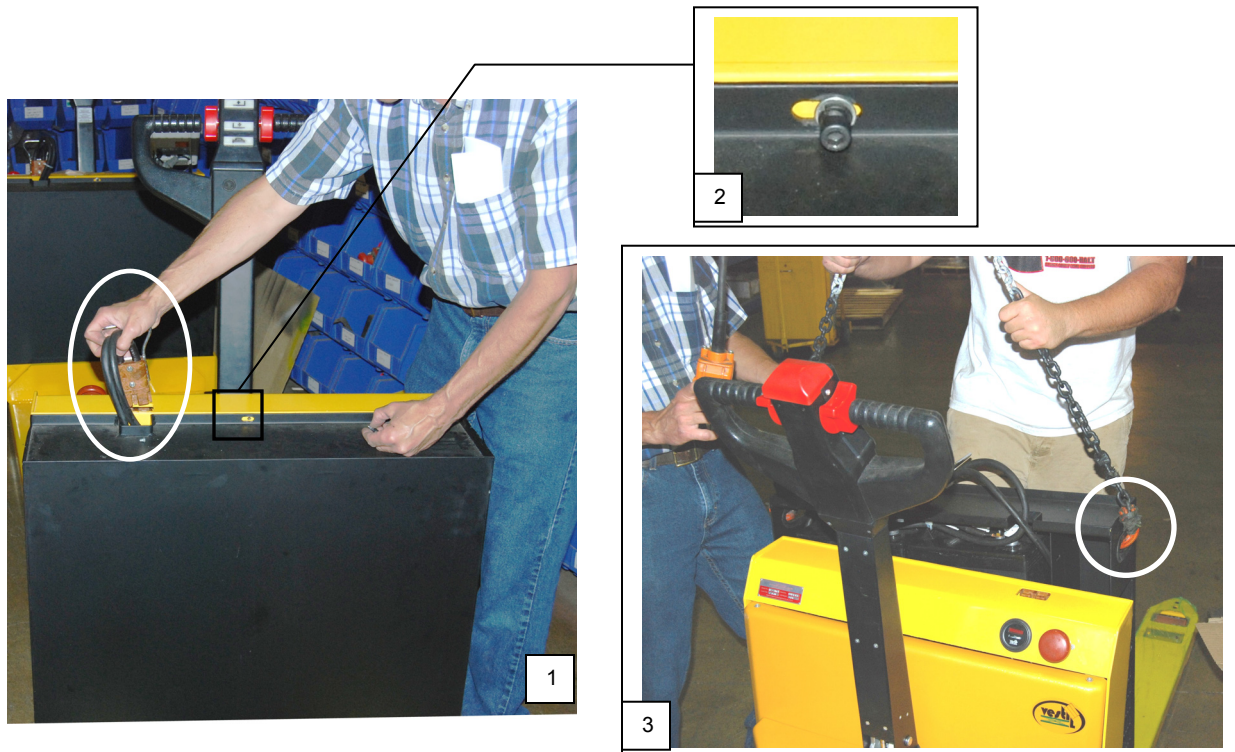
1. Remove all packing material.
2. Inform all personnel not participating in the unpacking process to clear the area.
3. Lift the EPT off of the pallet using either a hoist or a forklift with a capacity of at least 2,000 pounds. Always apply the proper hoisting procedures or forklift operation practices you learned during your training program.

### **To remove the EPT from the shipping pallet using a hoist:**

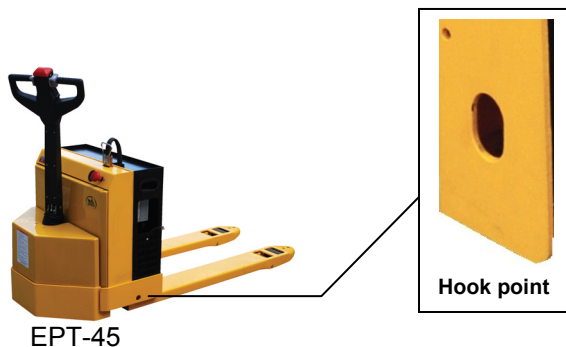
EPT-2###-45 models: Remove the battery box.

a) Disconnect the power cable from the socket on top of the EPT housing (circled in photo 1 below). Unfasten the box from the EPT frame by unscrewing the bolt in the center of the flange; the bolt is shown in photograph 2 (next page).

b) Connect the sling to both hook points on the EPT (1 on each side; the picture below only shows the hook point on the right side); then lift the unit no more than 6 – 8 inches above the pallet. The EPT will tilt towards the control yoke. Additionally, it may swing from side-to-side once free of the pallet if you did not properly position the hoist above the center of the sling. Stabilize the suspended truck with one hand, and stand safely to the side while operating the hoist.



**All Models:** Securely connect the sling hooks to the hook points (see photographs below), lift the EPT a few inches off of the pallet, direct the EPT away from the pallet, and then lower it until it is entirely supported by the ground.



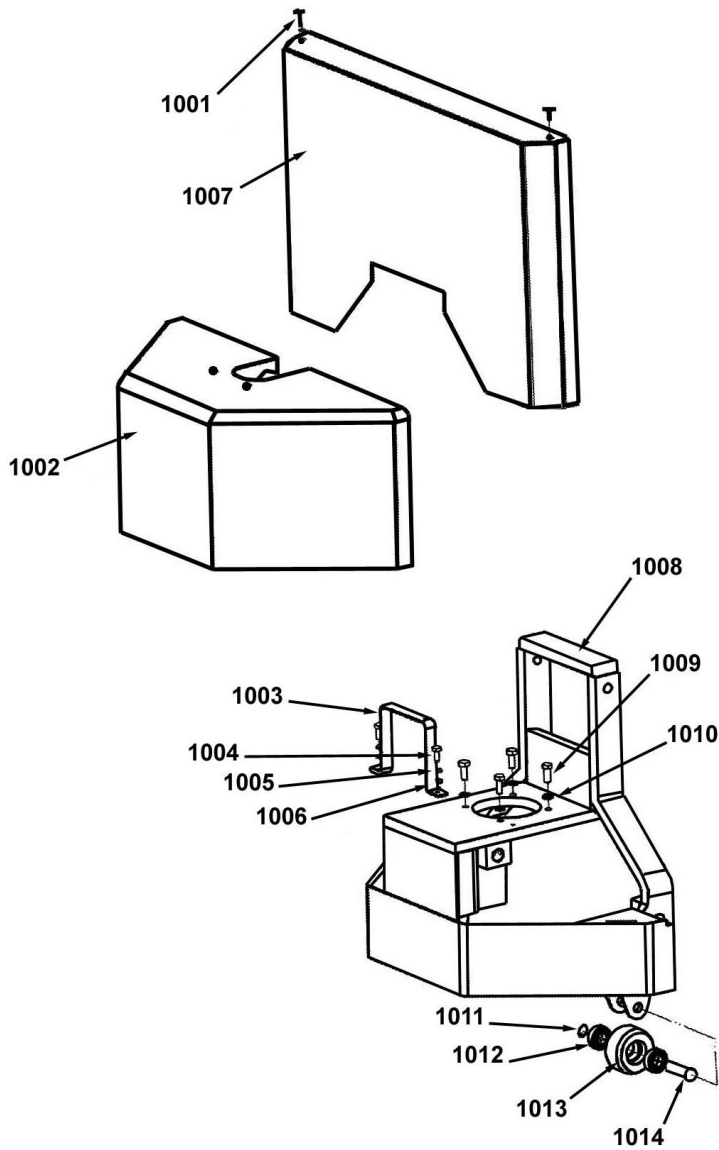
**To lift the EPT with a forklift:**

**NOTICE** Avoid contacting the drive wheel with the tines of your forklift; contact could damage the drive wheel.

Approach the pallet truck from the operator side. Lift the EPT just a few inches above the pallet. Slowly back the forklift away from the pallet, and then carefully lower the forks until the EPT rests firmly on the ground.

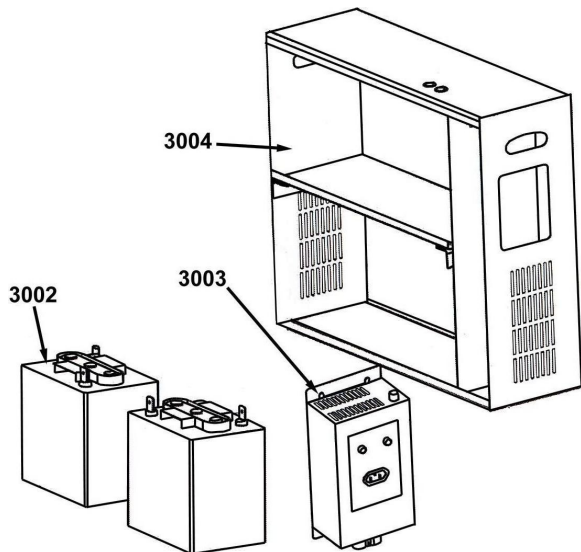


**FIG. 1: EPT-45 MAIN HOUSINGS AND SUPPORTING STRUCTURE**

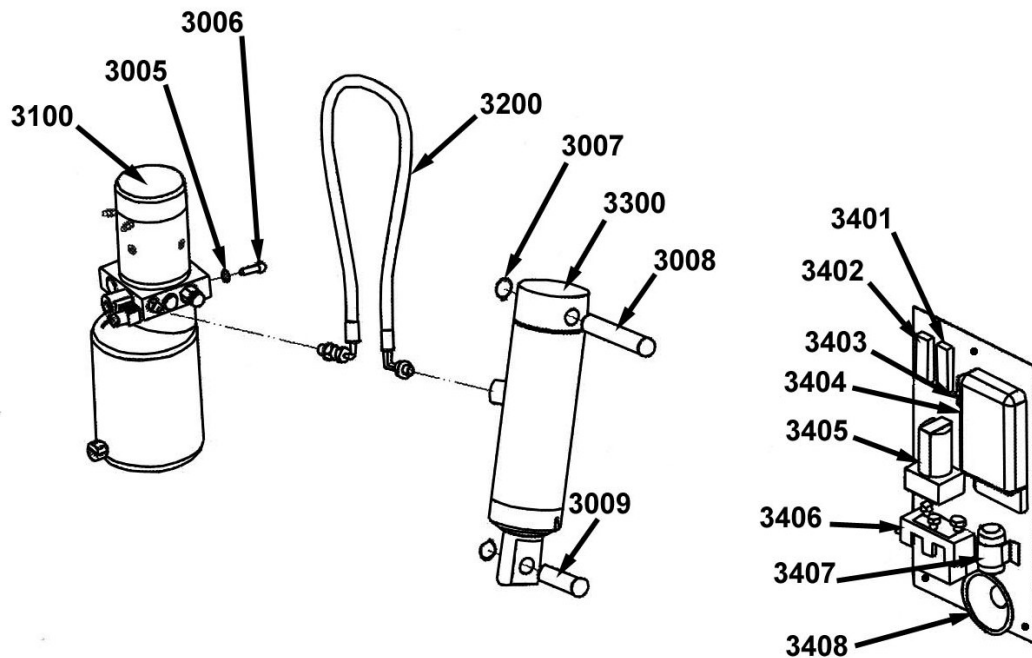


| Item No. | Part No.      | Description                         |
|----------|---------------|-------------------------------------|
| 1001     | EPT-45-1001   | M6 Hood Retaining Screw             |
| 1001     | EPT-45-1001-1 | M5 Hood Retaining Screw             |
| 1002     | EPT-45-1002   | Gear-Drive Cover (Fiberglass)       |
| 1002     | EPT-45-1002-2 | Gear-Drive Cover (Plastic)          |
| 1003     | EPT-45-1003   | Rear Cover Bracket                  |
| 1004     | EPT-45-1004   | Bolt                                |
| 1005     | EPT-45-1005   | Spring Washer                       |
| 1006     | EPT-45-1006   | Washer                              |
| 1007     | EPT-45-1007   | Rear Cover (Fiberglass)             |
| 1007     | EPT045-1007-2 | Rear Cover (Plastic)                |
| 1008     | EPT-45-1008   | Rear Frame                          |
| 1009     | EPT-45-1009   | Screw                               |
| 1010     | EPT-45-1010   | Spring Washer                       |
| 1011     | EPT-45-1011   | Snap Ring                           |
| 1012     | EPT-45-1012   | Bearing                             |
| 1013     | EPT-45-1013   | Wheel                               |
| 1013     | EPT-45-1013-2 | Complete Stabilizing Wheel Assembly |
| 1014     | EPT-45-1014   | Wheel Axle                          |

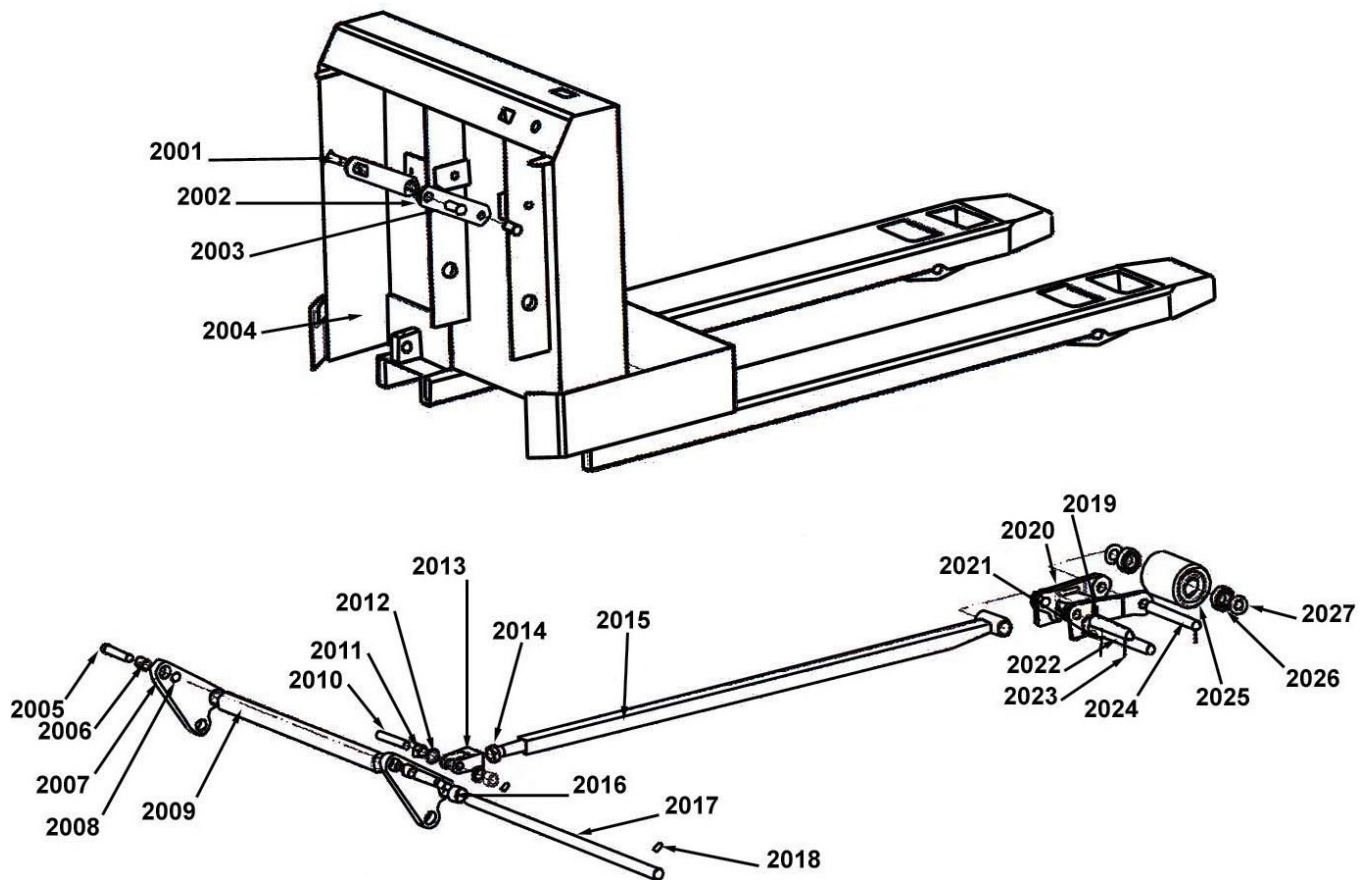
**FIG. 2: EPT-45 REMOVABLE BATTERY BOX AND COMPONENTS**



| Item No. | Part No.      | Description                  |
|----------|---------------|------------------------------|
| 3002     | EPT-45-3002   | Battery                      |
| 3003     | EPT-45-3003   | Battery Charger – OEM        |
| 3003     | EPT-45-3003-2 | Battery Charger – Soneil     |
| 3003     | EPT-45-3003-3 | Battery Disconnect Connector |
|          | EPT-CORD      | Battery Charger Cord         |
| 3004     | EPT-45-3004   | Battery Box                  |

**FIG. 3: EPT-45 CYLINDER AND FUSE PANEL**

| <u>Item No.</u> | <u>Part No.</u> | <u>Description</u> | <u>Item No.</u> | <u>Part No.</u> | <u>Description</u>                 |
|-----------------|-----------------|--------------------|-----------------|-----------------|------------------------------------|
| 3005            | EPT-45-3005     | Spring Washer      | 3401            | EPT-45-3401     | 150Amp Drive Motor Circuit Fuse    |
| 3006            | EPT-45-3006     | Bolt               | 3402            | EPT-45-3402     | 100Amp Pump Circuit Fuse           |
| 3007            | EPT-45-3007     | Retaining Ring     | 3403            | EPT-45-3403     | 5Amp Control Circuit Fuse          |
| 3008            | EPT-45-3008     | Upper Cylinder Pin | 3403            | EPT-45-3403-2   | Fuse Holder                        |
| 3009            | EPT-45-3009     | Lower Cylinder Pin | 3404            | EPT-45-3404     | Motor Controller                   |
| 3100            | EPT-45-3100     | Power Pack         | 3405            | EPT-45-3405     | Main Circuit Contactor             |
| 3200            | EPT-45-3200     | Hydraulic Hose     | 3406            | EPT-45-3406     | Forward/Reverse Contactor          |
| 3300            | EPT-45-3300     | Hydraulic Cylinder | 3406            | EPT-45-3406-2   | Forward/Reverse Contactor (Curtis) |
| 3300            | EPT-45-3300-2   | Hydraulic Cylinder | 3407            | EPT-45-3407     | Pump Motor Contactor               |
|                 |                 |                    | 3408            | EPT-45-3408     | Horn                               |

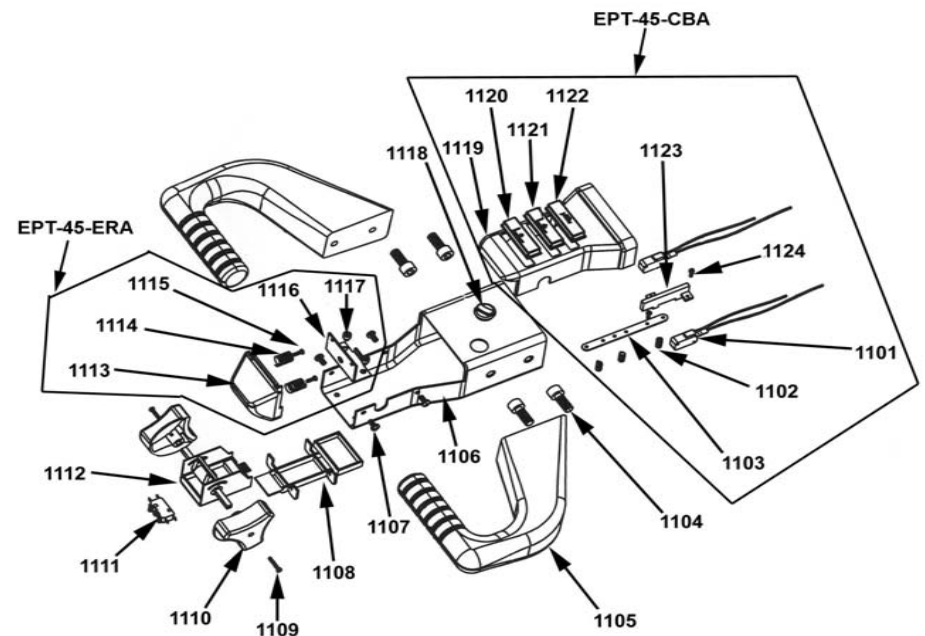
**FIG. 4:** EPT-45 FORK AND CARRIAGE ASSEMBLIES

| Item No. | Part No.      | Description                   | Item No. | Part No.      | Description           |
|----------|---------------|-------------------------------|----------|---------------|-----------------------|
| 2001     | EPT-45-2001   | Retaining Ring                | 2015     | EPT-45-2015   | Push Rod              |
| 2002     | EPT-45-2002   | Link Arm                      | 2016     | EPT-45-2016   | Sleeve Bearing        |
| 2003     | EPT-45-2003   | Sleeve Bearing 22 x 20        | 2017     | EPT-45-2017   | Trunion Shaft         |
| 2004     | EPT-45-2004   | Fork Frame                    | 2018     | EPT-45-2018   | Roll Pin              |
| 2004-2   | EPT-45-2004-2 | Upper Travel Limit Switch     | 2019     | EPT-45-2019   | Push Rod Pin          |
| 2005     | EPT-45-2005   | Pin                           | 2020     | EPT-45-2020   | Load Roller Frame     |
| 2006     | EPT-45-2006   | Sleeve Bearing 22 x 20        | 2021     | EPT-45-2021   | Roll Pin              |
| 2007     | EPT-45-2007   | Plate                         | 2022     | EPT-45-2022   | Load Roller Frame Pin |
| 2008     | EPT-45-2008   | Snap Ring                     | 2023     | EPT-45-2023   | Roll Pin              |
| 2009     | EPT-45-2009   | Trunion (caller must measure) | 2024     | EPT-45-2024   | Load Roller Pin       |
| 2010     | EPT-45-2010   | Clevis Pin                    | 2025     | EPT-45-2025   | Load Roller           |
| 2010-1   | EPT-45-2010-1 | Snap Ring                     | 2025     | EPT-45-2025-2 | Load Roller           |
| 2011     | EPT-45-2011   | Nut                           | 2026     | EPT-45-2026   | Bearing               |
| 2012     | EPT-45-2012   | Washer                        | 2027     | EPT-45-2027   | Washer                |
| 2013     | EPT-45-2013   | Clevis                        | 2028     | EPT-45-2028   | Roll Pin              |
| 2014     | EPT-45-2014   | Clevis Lock Nut               |          | EPT-45-KSA    | Key Switch Assembly   |

**FIG. 5:** EPT-45 Control Handle Assembly

| Item No. | Part No.      | Description                  |
|----------|---------------|------------------------------|
| 1101     | EPT-45-1101   | Micro Switch                 |
| 1102     | EPT-45-1102   | Spring                       |
| 1103     | EPT-45-1103   | Fixed Strip                  |
| 1104     | EPT-45-1104   | Screw                        |
| 1105     | EPT-45-1105   | Grip, Handle                 |
| 1106     | EPT-45-1106   | Frame, Control Handle        |
| 1107     | EPT-45-1107   | Screw, Phillips Head Machine |
| 1108     | EPT-45-1108   | Throttle Seat                |
| 1109     | EPT-45-1109   | Screw, Phillips Head Machine |
| 1110     | EPT-45-1110   | Throttle Knob                |
| 1111     | EPT-45-1111   | Switch, Micro                |
| 1112     | EPT-30-3115-2 | Assembly, Throttle           |
| 1112-2   | EPT-30-3115-3 | Assembly, Throttle           |
| 1113     | EPT-45-1113   | Cover, Emergency Reverse     |
| 1114     | EPT-45-1114   | Spring                       |
| 1115     | EPT-45-1115   | Screw, Phillips Head Machine |
| 1116     | EPT-45-1116   | Bracket, Emer. Rev. Cover    |
| 1117     | EPT-45-1117   | Bolt, Socket Head            |
| 1118     | EPT-45-1118   | High / Low Switch            |
| 1119     | EPT-45-1119   | Cover, Button                |
| 1120     | EPT-45-1120   | Lower Button                 |
| 1121     | EPT-45-1121   | Raise button                 |
| 1123     | EPT-45-1122   | Horn Button                  |
| 1124     | EPT-45-1123   | Bracket, Micro switch        |
| 1100     | EPT-45-1100   | Handle, Control (CH-1)       |
| 1100-1   | EPT-45-1100-1 | Button Assembly              |
| 1100-2   | EPT-45-1100-2 | Reverse Emergency, Assembly  |

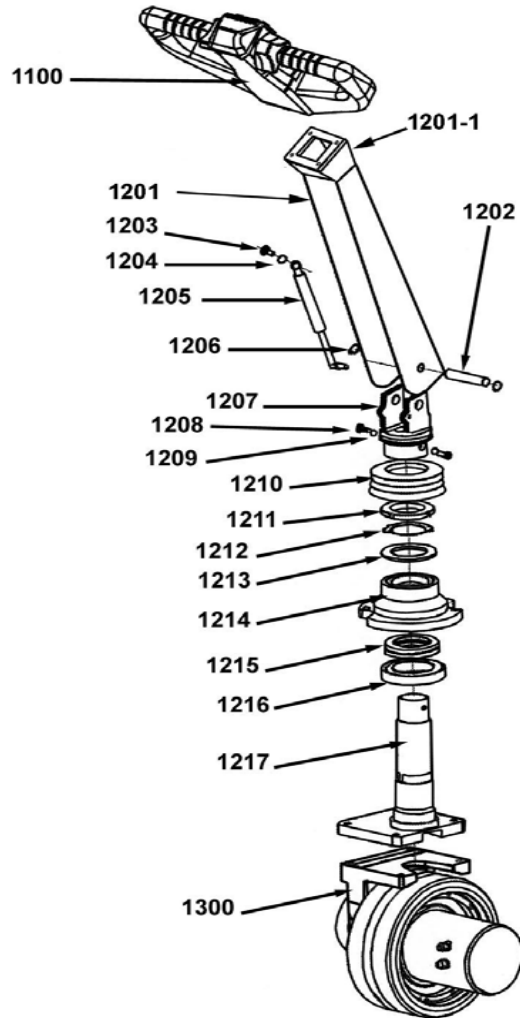
**CH-1 HANDLE ASSY.  
EPT-45**





**FIG. 6:** EPT-45 Drive Wheel Assembly

**EPT-2748-45  
DRIVE WHEEL  
ASSEMBLY**



| Item No. | Part No.      | Description                            |
|----------|---------------|--|
| 1201     | EPT-45-1201   | Tiller Arm                             |
| 1201-1   | EPT-45-1201-1 | Cover, Removeable                      |
| 1202     | EPT-45-1202   | Pin, handle Pivot                      |
| 1203     | EPT-45-1203   | Bolt, Socket Head                      |
| 1204     | EPT-45-1204   | Nut, Hex                               |
| 1205     | EPT-45-1205   | Spring, Pneumatic Handle ( Gas Shock ) |
| 1206     | EPT-45-1206   | Ring, Retaining                        |
| 1207     | EPT-45-1207   | Coupler, Handle                        |
| 1208     | EPT-45-1208   | Bolt, Socket Head                      |
| 1209     | EPT-45-1209   | Washer, Lock                           |
| 1210     | EPT-45-1210   | Cover, Coupler                         |
| 1211     | EPT-45-1211   | Nut, Steer Shaft Jam                   |
| 1212     | EPT-45-1212   | Washer, Spider                         |
| 1213     | EPT-45-1213   | Nut, Steer Shaft Jam                   |
| 1214     | EPT-45-1214   | Bearing Housing                        |
| 1215     | EPT-45-1215   | Bearing, Ball                          |
| 1216     | EPT-45-1216   | Bearing, Ball                          |
| 1217     | EPT-45-1217   | Steering Post                          |
| 1218     | EPT-45-1218   | Switch, Limit                          |
| 1200     | EPT-45-1200   | Motor, Drive                           |
| 1200-2   | EPT-45-1200-2 | Brush Kit for Drive Motor              |
| 1300     | EPT-45-11300  | Drive Wheel Assembly                   |

**FIG. 7:** Function Controls, Gauges, and Safety Features**BATTERY CHARGE GAUGE:**

The battery charge gauge indicates the status of the battery. It is located on top of the EPT main body and to the right of the control yoke. As the battery discharges, display lines disappear from right to left.



Always check the gauge before using the device; make sure that the battery is charged before using the pallet truck.

**BELLY SWITCH:**

The belly switch protects the operator from injury while driving the EPT in reverse. When pressed, the truck will change direction, i.e. move forward, for approximately 3 seconds; after 3 seconds it will stop completely. If the belly switch becomes jammed or stuck, the stacker will move forward (away from the operator) for at most 3 seconds; the control circuit will remain disabled until reset.

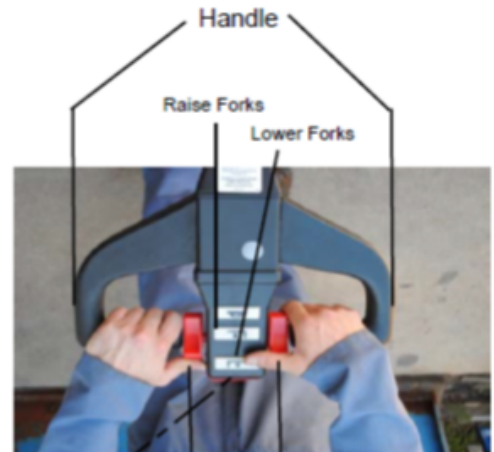
- To reset the circuit, either raise the handle to the fully vertical position (or simply release the handle), or press it downwards to the fully horizontal position.

**EMERGENCY STOP (“E-STOP”) BUTTON:**

Press the E-stop button to immediately interrupt all powered functions. Use the E-stop during operation if the travel or fork (raise and lower) functions do not respond normally to operator commands.



Use the E-stop as a service brake to secure the EPT when parked.



Belly Switch  
(Emergency Stop)

Movement Controllers  
("Butterfly" Switches)

**MOVEMENT CONTROLLERS:**

To drive the EPT in the **forward** direction, rotate the movement control forward with your thumbs as indicated by the solid arrow superimposed on photograph below. To move the pallet truck in **reverse**, rotate the control wheel in the opposite direction, which is shown with a dashed arrow.



Reverse Forward



The degree of rotation determines the speed of movement, so the farther you press the wheel in either direction, the faster the EPT will travel, up to a maximum speed of ~3mph when unloaded or ~2.6mph when loaded to capacity. Simply by releasing the movement control, the EPT will decelerate to a complete stop.

**USE INSTRUCTIONS:**

**1. Determine Condition of Floor or Other Supporting Surface:** Inspect the floor (or other surface; for example a parking lot, dock board or dock leveler) prior to use. The supporting surface must be smooth and dry so choose a route that avoids obstacles, spills, and surface damage.

**CAUTION** Casters might become stuck in gaps or cracks in the surface, which could cause the EPT to stop suddenly. A sudden stop can cause the load to shift and the load and truck might tip over.

**2. Inspect the EPT & Perform a Functions Test:****Inspection Prior to Use:**

ALWAYS inspect the unit before you use it. Begin the inspection by removing all debris found on the surface of the forks and the housing, and then:

- a. Check the forks for deformation and cracks;
- b. Check the floor beneath the truck and the truck itself for leaked hydraulic fluid or battery acid.

**WARNING** DO NOT use the EPT if you discover any damage or abnormalities. Tag the unit "Out-of-Service" and report the problem[s] to authorized maintenance personnel.

**Functions Test:**

Verify that the unit works properly. Drive the stacker to a location where the following tests can be performed without contacting overhead obstructions or items on the ground:

1. Raise the forks to the maximum elevation;
2. Return the forks to the lowest position.
3. Raise the forks, and while raising them, press the E-stop button. The forks should immediately stop moving. Reset the E-stop by returning the control yoke to either position 1 or 3 (see Operation Step 3 below on this page), and then pull up on the red button.
4. Fully raise the forks, and while lowering the forks press the E-stop. The forks should immediately stop moving. Reset the E-stop.
5. Drive the EPT in reverse at low speed and while driving press the belly switch. The machine should immediately move in the opposite direction for ~3 seconds and then stop. Reset the control yoke.
6. Drive the EPT in both the forward and reverse directions for a few seconds.
7. Test the horn (see Fig. 1, p. 9).
8. Verify that the control yoke automatically returns to the vertical position when released (see Operation Step 3 on this page).

**WARNING** Only use the pallet truck if all mechanisms function normally. If [a] malfunctions occurred, park the stacker in a safe location, tag it "Out-of-Service" and then report the malfunctions to maintenance personnel.

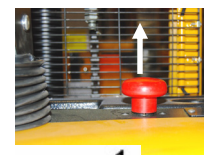
**Operation:**

Step 1: Turn on the power. [See "Power" callout box on p. 9].

Step 2: Pull the red E-Stop button up to disengage the service brake.

Step 3: Tilt the control yoke to the drive position (#2), which is shown in the photograph to the right.

**NOTE:** The EPT uses magnetic brakes, which engage when the handle is in or near either of the neutral positions (1 and 3). The yoke is designed to automatically return to neutral position #1 after the handle is released; therefore, the brakes will engage automatically as well.



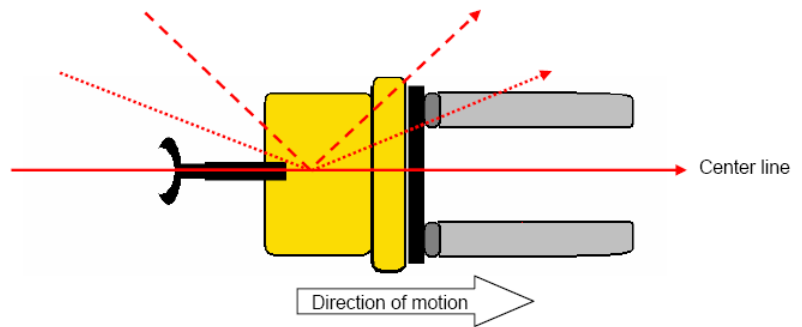
1 = Neutral

2 = Drive

3 = Neutral

Step 4: Rotate the movement control wheel in the appropriate direction to move either forward or in reverse. [See "Movement Controls" text box and the corresponding photo on p. 9]

**Step 5:** Drive the pallet truck to the desired location. To steer the unit, turn the yoke to the right or left of the center line. Moving the yoke to the right will cause the EPT to turn to the right, and moving the yoke to the left of the center line will cause the unit to turn left. The degree of deflection from the centerline determines how sharply the EPT turns. The illustration at right demonstrates how the position of the yoke determines the direction the machine follows.



### **Lifting and Transporting Loads:**

**WARNING** DO NOT operate the EPT until you read AND understand every instruction. If you do not understand an instruction, contact Vestil for clarification. To reduce the possibility of sustaining or causing serious personal injuries, ALWAYS:

1. Make sure that all other persons clear the area while you use the EPT.
2. Apply the fork truck operation and lifting practices learned during your operator training, and applied by your employer. Follow the instructions below ONLY to the extent that they do not disagree with the operating practices required by your employer.
  - Make sure that the net weight to be lifted (load + skid) does not exceed the rated load (capacity) of your truck;
  - Center and evenly distribute the load on the forks. The load must not project more than 2" beyond the tips of the forks.
3. Review the safety guidelines on p. 3 before each use:
  - Apply proper loading techniques (p. 8);
  - Ask a coworker to help you load and unload the lifter.
4. "Operator" means a person, who is trained and authorized to use a manually propelled high lift device. ONLY persons who have successfully completed a training program, like the courses outlined on p. 4-5 of B56.10-2006, should operate the HYRDA-Lift. Safe operation requires operators to:
  - Develop safe working habits and a process for identifying hazards that exist or might be encountered during operation;
  - Conduct thorough inspections of the usage area to identify unusual/hazardous conditions. Walk the path you will use to transport loads with the lifter beforehand. Do not use the HYDRA lift if the floor (or other supporting surface) is uneven or damaged or cannot support the combined weight of the operator, the lifter and the load.
  - Make sure that the lifter has been inspected as recommended in the "Inspections & Maintenance" section of this manual (p. 9). Use the lifter ONLY IF it is deemed safe to use by designated inspection personnel.

To engage a pallet/skid, drive the unit to a position in front of the intended load. Before engaging the load, confirm that the forks will fit within the fork pockets. Fully lower the forks to allow them to slide into the fork pockets of the skid. Confirm that the net weight of the load plus the skid do not exceed the capacity of the EPT.

Continue forward until either the skid rests against the back (vertical/upright portion), or the forks are as far underneath the skid as they can be. When the skid contacts the back of the forks, put the yoke in a neutral position to stop forward motion. Wait until the stacker stops completely, and then lift the skid off of the ground/supporting surface by pressing one of the two fork raising buttons. [See Fig. 1 on p. 9].

**Proper Transport Configuration:** To avoid unintended contact between the skid/pallet and surface features, transport the load to the desired location with the forks elevated.

To release the load, stop in the desired location; fully lower the forks; and then slowly drive the EPT forward until the forks are no longer beneath the skid/pallet.

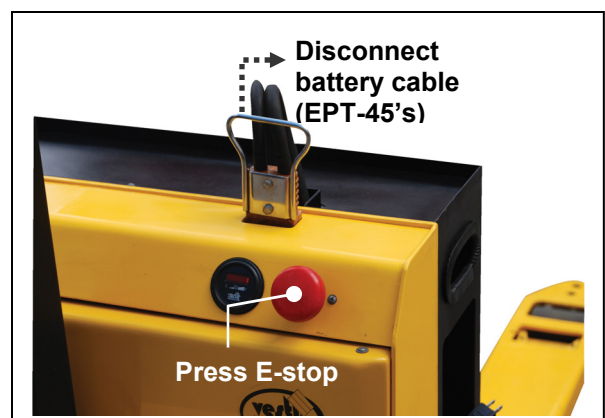
### **Batteries and Charger:**

**DANGER** The charger allows electrical current to flow from a wall socket through the batteries. While operating the charger, contact with water (rain, snow, etc.) could result in electric shock or electrocution. Do NOT recharge the batteries if the EPT is outdoors. Only recharge the batteries indoors.

Turn off your EPT:

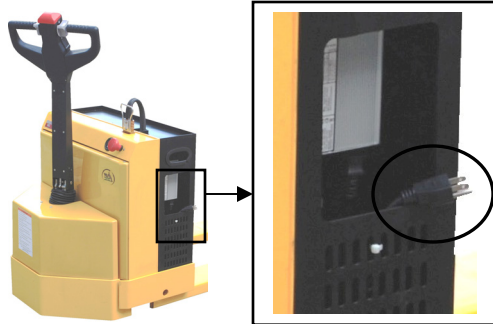
- EPT-45's: Push E-stop to turn off the EPT;
- EPT-30's: Press the E-stop button and turn the key switch to the off position;

Disconnect the battery cable (EPT-45's);



Plug the charger's AC cord into an 115VAC power source:

- EPT-45's: the AC cord is tucked inside the battery box on the right side (circled in the second photo below)



Plug this end into a standard 115 volt outlet and charge batteries for at least 8 hours. The charger will not overcharge the batteries, so leaving the unit plugged in overnight or over a weekend is ok. However, the **charger should only be used indoors!** When the charge cycle completes, disconnect the AC cord from the outlet, and reinstall the tray (EPT-30's).

Storing the EPT: Unload the lifter; then return it to the designated storage location.

**NOTICE** A proper storage location is one where the unused lifter will not:

1. Interfere with or obstruct traffic or other operations;
2. Be exposed to corrosive chemicals or water, either as a consequence of weather or of worksite conditions.

**TROUBLESHOOTING:**

**⚠WARNING** Before performing any corrective action described in the following table, block the drive wheel off of the ground.

Contact Vestil for problems at time of installation, or for any problems not addressed below.

| <b><u>Problem:</u></b>   | <b><u>Possible cause(s):</u></b>   | <b><u>Action:</u></b>  |
|--|--|--|
| Unit does not respond to movement controls (does not move either forward or in reverse).   | Battery voltage low (battery charge lower than 17 Volts)                       | Charge batteries.<br>Bad batteries; load test batteries and replace if necessary.  |
|  | Problem with motor controller (check for LED flash code on side of controller) | Consult diagnostics page Table 2 Troubleshooting Chart; or Refer to 15-124-029 electrical drawing for proper voltage readings and operation; or Consult Factory                      |
| Unit will not charge   | Fuse blown   | Remove back shroud and check fuses (3 fuses).  |
|  | Charger malfunction  | Verify output voltage on charger, it should be 26 to 30 volts, dc, connected to batteries, and plugged into 115vac.  |
| Unit will not go forward; reverse works; belly switch just kills unit (does not go forward and faults out)   | Bad batteries  | Load test the batteries  |
|  | Broken wire, or loose connection   | Locate Pin 2 on Molex connector at motor controller. Trace wiring to contactor and verify connection.  |
|  | Contactor bad, motor controller bad  | While attempting to go forward, tap on the contactor with a screwdriver handle. If the unit moves forward, then the contactor may need replaced, or plungers lubed with a light oil. |
|  |  | Remove both wires from each side of the contactor, and check with ohm meter; resistance should be approximately 38 ohms. If it's open or zero, the contactor should be replaced.     |
| Unit will not go reverse; belly switch works (i.e. when the handle is in operating range and rotating throttle in reverse and the belly switch is hit, the unit moves forward and times out) | Broken wire, or loose connection, contactor bad, motor controller bad          | Consult diagnostics page Table 2 Troubleshooting Chart; or Refer to 15-124-029 electrical drawing for proper voltage readings and operation; or Consult Factory.                     |
|  |  | Same as above; except locate Pin 3 on Molex connector on motor controller...and follow procedure.  |

**Problem:**

Unit will not go forward, or reverse.

**Possible cause(s):**

Broken wire, or loose connection, bad motor controller.

**Action:**

Locate Pin 6 on Molex connector at the motor controller. Try to drive the unit in forward, there should be 0 to 5 volts (5V is full throttle) at this pin. If there is voltage at pin 5, and 24 volts on either pin 11, or 12 and the unit does not move, the motor controller may be bad. Consult diagnostics page Table 2 Troubleshooting Chart; or Refer to 15-124-029 electrical drawing for proper voltage readings and operation; or Consult Factory.

Throttle assembly bad

If the connections are all good, and there is no voltage coming out of throttle assembly, then the throttle assembly may be bad. Verify there is 24 volts going into the throttle assembly, and that there is a good ground. If there is still no output voltage for pin 6, or forward and reverse outputs replace throttle assembly. Consult diagnostics page Table 2 Troubleshooting Chart; or Refer to 15-124-029 electrical drawing for proper voltage readings and operation; or Consult Factory

Unit will not move forward, or reverse, and the Belly switch will not function, unit does turn on as indicated by the battery gage lighting up.

Blown fuse

Verify fuses are good, replace if blown.

Broken wire, or loose connection

Locate Pin 7 on Molex connector at the motor controller. Trace wire back up to tiller head and verify continuity all the way to the throttle assembly. Repair any loose connections.

When replacing throttles, it may be necessary, and does not hurt to run a jumper wire from pin 7 to B-.

Check the ground wire that comes off of "B-" on the motor controller. Re-terminate with a ring terminal if loose.

Run jumper wire around large diode coming off of small AGC fuse. If this diode is bad it can cause the unit to not move.

**Problem:**

Unit will not go forward; the belly switch functions; reverse works.

**Possible cause(s):**

Broken wire, or loose connection, bad motor controller

**Action:**

Locate Pin 11 on Molex connector at the motor controller. Try to drive the unit in forward, there should be 24 volts at this pin. If there is voltage and the unit does not move, the motor controller may be bad. If there is no voltage, trace the wiring back towards the tiller head and check voltage on each side of connectors. Continue this until bad connection is found.

Bad throttle assembly

If the connections are all good, and there is no voltage coming out of throttle assembly, then the throttle assembly may be bad. Verify there is 24 volts going into the assembly, and that there is a good ground. If there is still no output voltage for pin 11, replace throttle assembly. Reference 15-124-029.

Belly switch does not function; forward ok; reverse ok

Broken wire, or loose connection, bad motor controller

Locate Pin 13 on Molex connector at the motor controller. Try to drive the unit in reverse, and hit the belly switch... there should be 24 volts at this pin. If there is voltage and the unit does not move, the motor controller may be bad. If there is no voltage, trace the wiring back towards the tiller head and check voltage, or continuity on each side of connectors. Continue this until bad connection is found.

Bad belly switch

If the connections are all good, and there is no voltage, then the switch may be bad. Verify there is 24 volts going into the switch; and check to see if it is coming back out of the switch when depressed. If there is no output voltage, replace the switch.

Unit will not move at all.

Stuck Switch

The belly switch is stuck on. Tap the orange belly switch assembly to see if the switch can be freed. If this doesn't work, disassemble the tiller head by removing 3 screws from bottom. Slightly loosen up the two screws that hold the switch in place, this may free the switch. If it is still stuck, contact the factory for a replacement switch.



| <b><u>Problem:</u></b>                                    | <b><u>Possible cause(s):</u></b>      | <b><u>Action:</u></b>   |
|---|---------------------------------------|---|
| Unit will not raise; motor does not run                   | Loose wire                            | Verify 24 volts at coil when raise is pushed, if no voltage, trace wiring back to tiller head looking for voltage on each side of the connectors until the bad connection is found.   |
|   | Bad solenoid                          | If voltage is present at the solenoid and the unit does not raise, remove the two wires to the coil and measure the coil resistance. It should be around 19 ohms. If it's open, or shorted replace the solenoid.  |
|   | Upper limit switch out of adjustment  | Bypass upper limit switch and see if the unit raises...DO NOT TAKE IT ALL THE WAY UP... If it does raise, verify the limit switch is normally closed and will open when activated. If the limit switch is ok, try to adjust the switch accordingly so that the units raise height is approximately 7 to 8"  |
| Unit will not raise; motor runs                           | Blown fuse<br>Lower solenoid stuck on | Check fuses.<br>Check to see if the lowering switch is stuck on. If it is, remove the tiller head via 3 screws on bottom and replace switch, or tap on switch to see if it can be freed up. If the lower switch is not stuck "on," the pump could be bad, consult factory.  |
| Unit will not lower                                       | Loose wire; bad coil                  | Verify 24 volts at coil when lower is pushed, if no voltage, trace wiring back to tiller head looking for voltage on each side of the connectors until the bad connection is found.<br><br>If voltage is present at the coil and the unit does not lower, remove the connector to the coil and measure the coil resistance. It should be around 39 ohms. If it's open, or shorted replace the coil. |
|   | Upper limit switch out of adjustment  | Loosen hydraulic line at pump to relieve pressure build up. Re-adjust limit switch so unit stops at 7 to 8 inches above the ground.   |
| Unit keeps blowing fuses when the raise button is pressed | Shorted solenoid for motor raise      | Remove the wire to the solenoid coil on the pump motor. Measure the resistance, it should be around 19 ohms. If it is nearly zero ohms replace the solenoid.  |

**Problem:**

Unit will not reverse; belly switch does not function; forward ok

**Possible cause(s):**

Broken wire, or loose connection, bad throttle assembly, bad motor controller.

**Action:**

Locate Pin 12 on Molex connector at the motor controller. Try to drive the unit in reverse, there should be 24 volts at this pin. If there is voltage and the unit does not move, the motor controller may be bad, consult factory. If there is no voltage, trace the wiring back towards the tiller head and check voltage on each side of connectors. Continue this until bad connection is found. If the connections are all good, and there is no voltage coming out of throttle assembly, then the throttle assembly may be bad. Verify there is 24 volts going into the assembly, and that there is a good ground. If there is still no output voltage for pin 12, replace throttle assembly. Reference 15-124-029.

## Maintenance and Inspections:

According to ANSI B56.1, the pallet truck is a “motorized hand truck, pallet truck” (MHT). For this type of lift truck, only trained, authorized persons should perform inspections or maintenance.

**Inspections:** ALWAYS review the following warning messages and procedures BEFORE inspecting the MHT.

**⚠️WARNING** DO NOT use the pallet truck if an inspection reveals structural damage. Structural damage includes, but is not limited to, cracked welds, warping or other deformation of the cylinder brackets, forks, front rollers and wheel(s), handle, or the housing that protects the electrical components.

**If an inspection exposes any problem, restore the MHT to normal operating condition BEFORE returning it to regular service. The MHT must not be used until all repairs have been completed.**

**NOTICE** According to B56.1-2005:

- A “User” is “a person or organization responsible for employing powered industrial trucks.” Therefore, the person or business that owns the MHT is a user.
- “Authorized” means any person designated by the user to operate or maintain the equipment. In other words, the owner, most likely your employer, is responsible for training and selecting people to inspect and maintain the MHT.

**NOTE:** A user may choose to contract with a person or an organization for maintenance services. **Vestil is not responsible for the actions of independently contracted maintenance service providers.**

- DO NOT use brake fluid or jack oil in the hydraulic system. If oil is needed, use an anti-wear hydraulic oil, viscosity grade 150 SUS at 100°F, (ISO 32 @ 40°C), or a non-synthetic transmission fluid.
- Only use replacement parts either supplied or approved by the manufacturer.

The person(s) authorized **by the end-user** to inspect the MHT must do so before it is used for the first time, and before each subsequent use. If the MHT is rarely used, inspect the unit at least once per month, or before each use, whichever is more frequent. Before the inspection, a) disconnect the battery, and b) either chock the wheels or lift the MHT until the drive wheels no longer contact the ground.

Inspect the pallet truck prior to each use. Specifically look for:

1. Frayed wires;
2. Oil leaks;
3. Pinched or damaged hoses;
4. Structural damage: cracked welds, warping or other deformation of the cylinder brackets, forks, front rollers or drive wheel(s), handle, or the housing that protects the electrical components;
5. Proper function of all limit switches;
6. Proper horn operation;
7. Normal battery condition: clean, not leaking electrolyte solution, secure connections with both terminals. Also make sure that the battery is immobilized so that it cannot move during operation.
8. Proper rotation of all wheels.

Inspect the MHT each month:

1. Oil level: raise the forks to the maximum height; when the cylinder(s) are properly filled, the oil level should be 1-1/2 to 2 inches below the reservoir fill hole. Return the forks to the fully lowered position.
2. Damage to or excessive wear of:
  - a. Pivot points;
  - b. Hydraulic hoses;
  - c. Electric wires;
  - d. Retaining rings for the rollers, drive wheels, and all pivot points;
  - e. Bearings
3. Wobbliness or looseness of rollers and/or drive wheels;
4. Proper function of the hand or foot actuated mechanisms;
5. Proper battery water level;
6. Unusual noise or abnormal movement during operation;
7. Legibility and undamaged condition of all product labels.

**Maintenance:** the end-user must implement a scheduled maintenance program to ensure the proper function and safety of the lifter. Pages 12-13 of ANSI/ITSDF standard B56.1-2005 describe some recommended maintenance procedures, and the following steps should be utilized in conjunction with those recommendations.

**⚠️WARNING** The user is responsible for training persons to work on the MHT. “Work on” refers to operating, loading, cleaning, servicing, maintaining, or repairing the product. ONLY trained, authorized maintenance personnel or independent contractors chosen by the user should perform inspection, maintenance, or repair work.

Step 1: Tag the MHT, "Out of Service."

Step 2: Complete an every use and a monthly inspection. If deformity, corrosion, rusting, or excessive wear of structural members is present, DO NOT use the MHT. Contact Vestil for instructions.

- 49 -

Step 3: Remove any dirt or other matter from the forks and other surfaces.

Step 4: Perform all other necessary adjustments and/or repairs, but DO NOT modify the truck.

**⚠WARNING** The reader should understand the significant difference between necessary adjustments and repairs, and modifications.

An adjustment is a simple correction that restores the MHT to normal operating condition, such as tightening loose fasteners, or removing dirt or other debris from the surface; a repair refers to replacing worn parts with new or replacement parts.

➤ DO NOT use the truck if adjustments and/or repairs are incomplete! Return it to service ONLY after finishing all necessary repairs and adjustments.

A modification is a change that alters the MHT from normal operating condition, like bending the structural members or removing a part or several parts. **NEVER modify the unit without the express, written approval of Vestil.**

**Modifications may render the product unsafe to use.**

Step 5: Make a dated record of the repairs, adjustments and/or replacements made.

**MARKINGS:**

Only use the lifter if ALL labels are readable and undamaged. Contact Vestil for replacement labels if necessary, and DO NOT use the pallet truck until all replacement labels are affixed to the device.

Proper label placement is shown below:

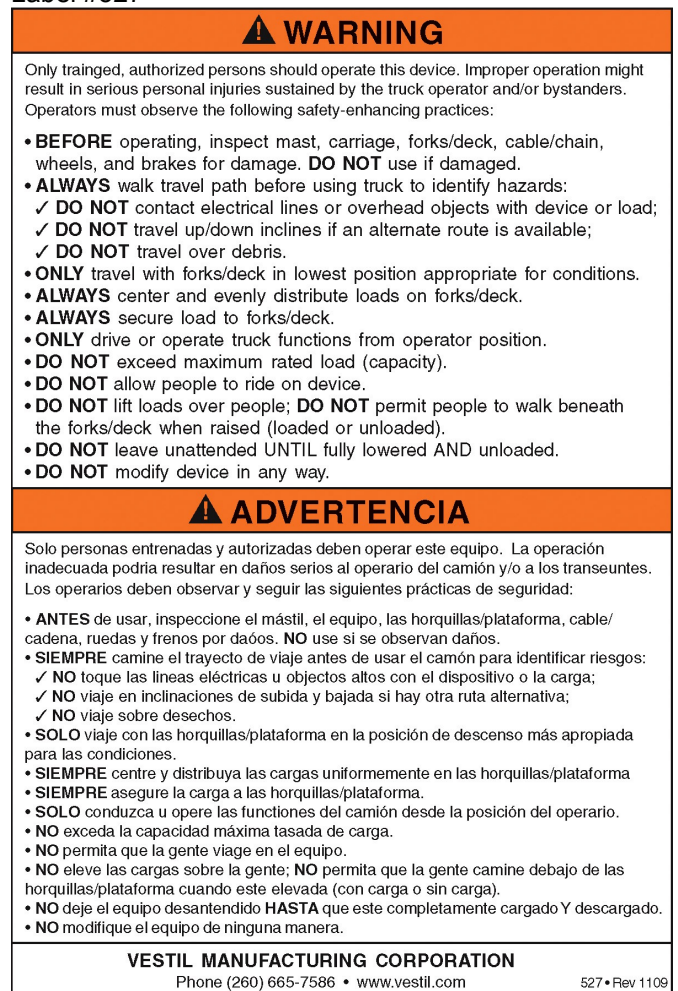
Label #206



Label #220



Label #527



Label #295



Label #208



## LIMITED WARRANTY

Vestil Manufacturing Corporation (“Vestil”) warrants this product to be free of defects in material and workmanship during the warranty period. *Our warranty obligation is to provide a replacement for a defective original part if the part is covered by the warranty, after we receive a proper request from the warrantee (you) for warranty service.*

### Who may request service?

Only a warrantee may request service. *You are a warrantee if* you purchased the product from Vestil or from an authorized distributor AND Vestil has been fully paid.

### What is an “original part”?

An original part is a part used to make the product as shipped to the warrantee.

### What is a “proper request”?

A request for warranty service is proper if Vestil receives: 1) a photocopy of the Customer Invoice that displays the shipping date; AND 2) a written request for warranty service including your name and phone number. Send requests by any of the following methods:

Mail  
Vestil Manufacturing Corporation  
2999 North Wayne Street, PO Box 507  
Angola, IN 46703

Fax  
(260) 665-1339  
Phone  
(260) 665-7586

Email  
sales@vestil.com

In the written request, list the parts believed to be defective and include the address where replacements should be delivered.

### What is covered under the warranty?

After Vestil receives your request for warranty service, an authorized representative will contact you to determine whether your claim is covered by the warranty. Before providing warranty service, Vestil may require you to send the entire product, or just the defective part or parts, to its facility in Angola, IN. The warranty covers defects in the following *original* dynamic components: motors, hydraulic pumps, electronic controllers, switches and cylinders. It also covers defects in *original* parts that wear under normal usage conditions (“wearing parts”): bearings, hoses, wheels, seals, brushes, batteries, and the battery charger.

### How long is the warranty period?

The warranty period for original components is 90 days. The warranty period begins on the date when Vestil ships the product to the warrantee. If the product was purchased from an authorized distributor, the period begins when the distributor ships the product. Vestil may extend the warranty period for products shipped from authorized distributors by *up to* 30 days to account for shipping time.

### If a defective part is covered by the warranty, what will Vestil do to correct the problem?

Vestil will provide an appropriate replacement for any *covered* part. An authorized representative of Vestil will contact you to discuss your claim.

### What is not covered by the warranty?

1. Labor;
2. Freight;
3. Occurrence of any of the following, which automatically voids the warranty:
  - Product misuse;
  - Negligent operation or repair;
  - Corrosion or use in corrosive environments;
  - Inadequate or improper maintenance;
  - Damage sustained during shipping;
  - Collisions or other incidental contacts causing damage to the product;
  - Unauthorized modifications: DO NOT modify the product IN ANY WAY without first receiving written authorization from Vestil. Modification(s) might make the product unsafe to use or might cause excessive and/or abnormal wear.

### Do any other warranties apply to the product?

Vestil Manufacturing Corp. makes no other express warranties. All implied warranties are disclaimed to the extent allowed by law. Any implied warranty not disclaimed is limited in scope to the terms of this Limited Warranty.

