

TRIPLE-BIN RECYCLING HOPPER - ENVIR-BIN

APPROX WEIGHT: 755.96 lbs.
DOES NOT INCLUDE WEIGHT OF POWER OR PACKAGING!!!

*** ANY ADDITIONS, DELETIONS, OR OMISSIONS MUST BE CORRECTED ON THIS DRAWING AS THIS DRAWING WILL BE CONSIDERED ALL INCLUSIVE ***

ALL GRAPHICS PROVIDED ARE FOR REFERENCE ONLY. IF CERTAIN DIMENSIONS ARE CRITICAL PLEASE VERIFY THOSE DIMENSIONS WITH YOUR SALESPERSON

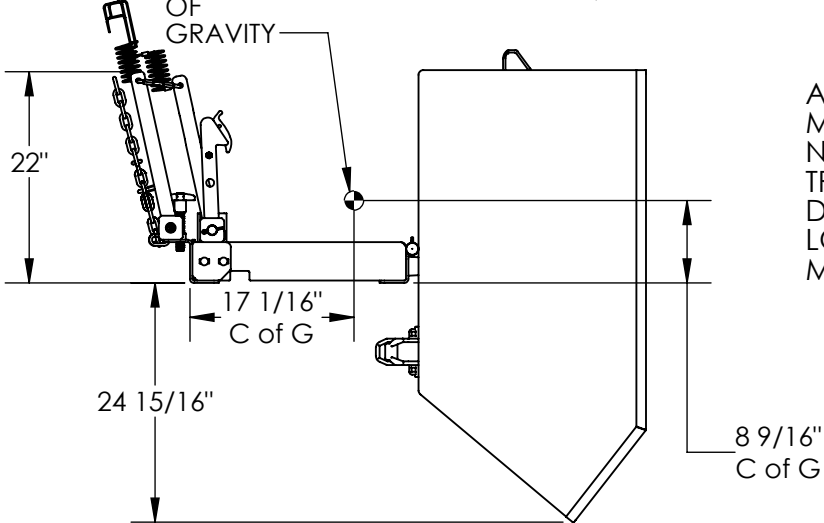
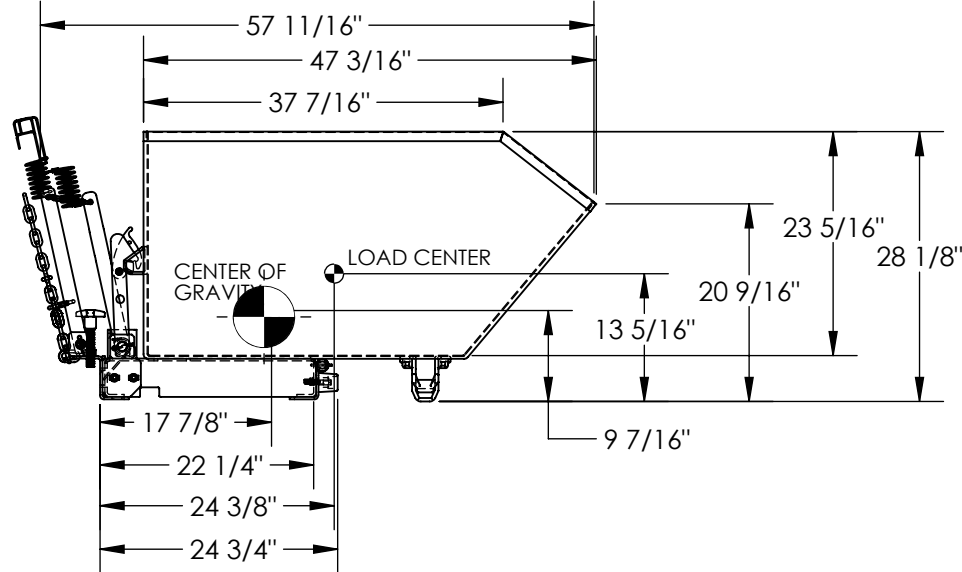
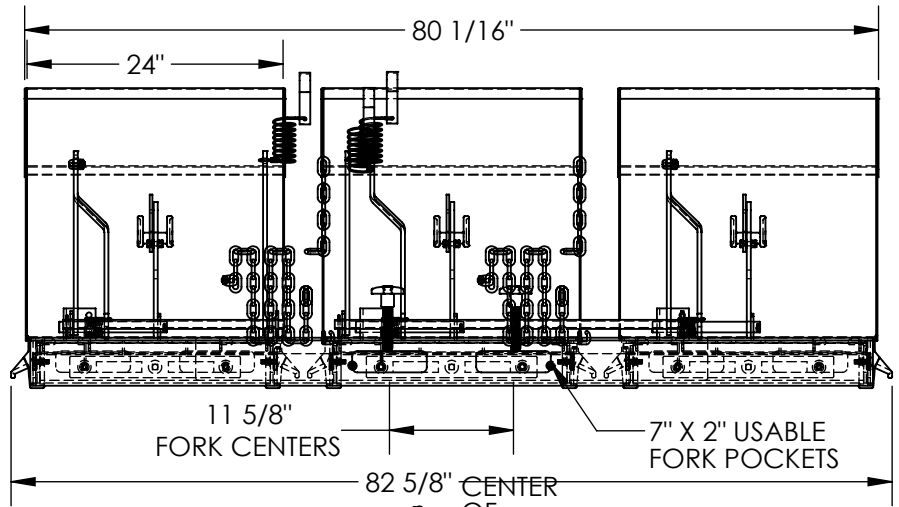

APPROX. WEIGHT/ LOST LOAD= 755.96 LBS. (APPROX)
MINIMUM EFFECTIVE THICKNESS= FORK LENGTH MINUS 22 1/4"
NEVER EXCEED LOAD CENTER RATING PER FORK
TRUCK MANUFACTURER'S GUIDELINES.
DO NOT USE THIS FORK TRUCK ATTACHMENT IF
LOAD WILL EXCEED FORK TRUCK
MANUFACTURER'S LOAD CENTER RATING.

DIMENSION TOLERANCE ± 1/4"

STANDARD FEATURES

- MODEL NUMBER IS: ENVIR-BIN
- OVERALL WIDTH: 82 5/8"
- OVERALL LENGTH: 57 11/16"
- OVERALL HEIGHT: 28 1/8"
- INDIVIDUAL BIN INSIDE WIDTH: 24"
- INDIVIDUAL BIN INSIDE LENGTH: 47 3/16"
- INDIVIDUAL BIN INSIDE HEIGHT: 23 5/16"
- CAPACITY: 2,000 LBS. TOTAL
- INDIVIDUAL BIN VOLUME: 1/2 CU. YARD.
- BINS UNIQUELY IDENTIFIED BY 3 DIFFERENT COLORS
- TOUGH BAKED IN POWDER COATED
- GREEN, RED, AND BLUE FINISH

SPECIAL FEATURES

NONE

APPROVAL

I, THE UNDERSIGNED, AGREE THAT THE PRODUCT AS REPRESENTED SATISFIES DESIGN AND DIMENSION REQUIREMENTS. I ALSO ACKNOWLEDGE MY DUTY TO CONFIRM PRODUCT AND INSTALLATION COMPLIANCE WITH ALL APPLICABLE FEDERAL, STATE AND LOCAL REGULATIONS AND STANDARDS.

UNITS REQUIRING APPROVAL DRAWINGS OR MODIFIED ARE NON-RETURNABLE

As drawn As marked

Signed: _____ Date: _____

Printed Name: _____

LEAD TIME WILL START UPON RECEIPT OF SIGNED APPROVAL DRAWING

DISTRIBUTOR'S NAME:		P.O.#
VESTIL MANUFACTURING		X
DRAWN BY: LG		W.O.#
DATE: 07/08/11		X
REFERENCE: X	SCALE: 1:20	SALES: X
QUOTED LEAD TIME: X	QUOTE # X	FILE NAME:
		37-007-092