

HINGE TILT TABLE - EHTT

APPROX WEIGHT: 657.6956 lbs.
 DOES NOT INCLUDE WEIGHT OF POWER OR PACKAGING!!!

*** ANY ADDITIONS, DELETIONS, OR OMISSIONS MUST BE CORRECTED ON THIS DRAWING AS THIS DRAWING WILL BE CONSIDERED ALL INCLUSIVE ***

ALL GRAPHICS PROVIDED ARE FOR REFERENCE ONLY. IF CERTAIN DIMENSIONS ARE CRITICAL PLEASE VERIFY THOSE DIMENSIONS WITH YOUR SALESPERSON

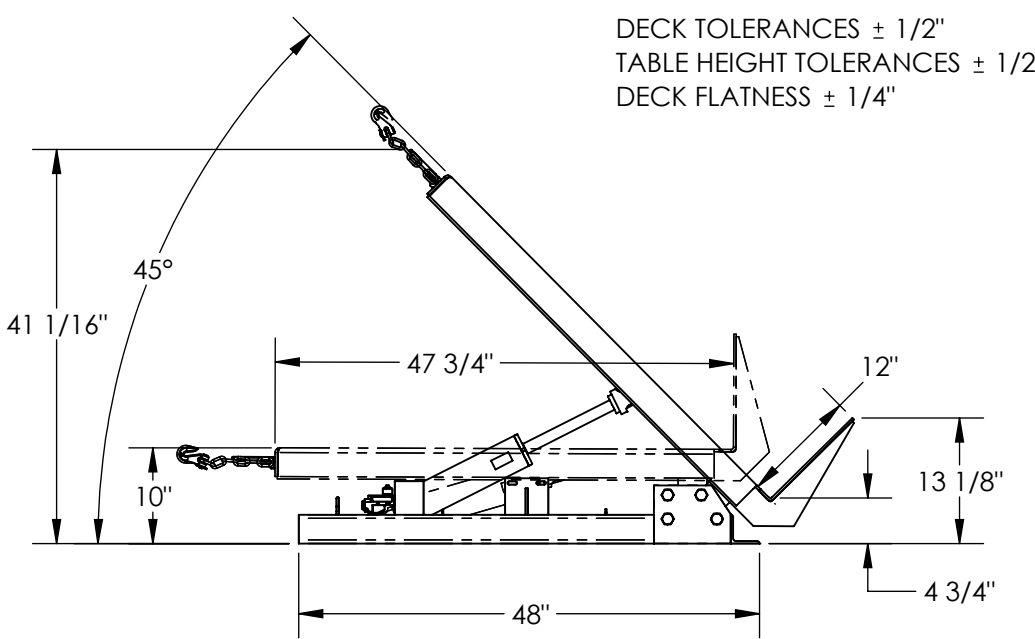

DECK TOLERANCES $\pm 1/2$ "
 TABLE HEIGHT TOLERANCES $\pm 1/2$ "
 DECK FLATNESS $\pm 1/4$ "

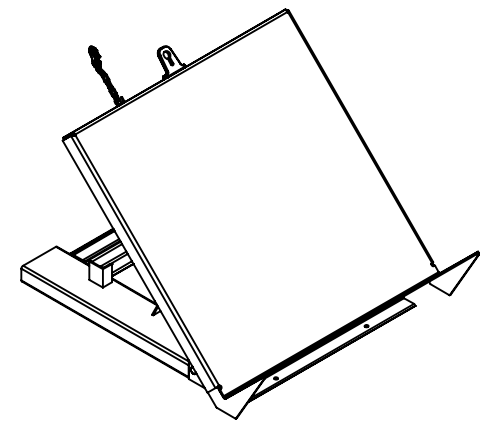
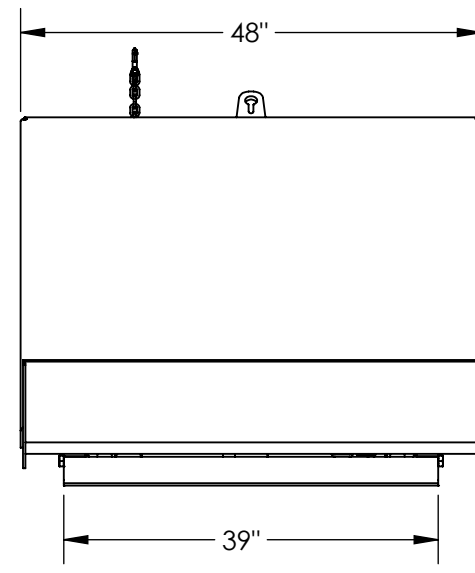

PLEASE CIRCLE SPECIFICATIONS:

POWER	<input checked="" type="checkbox"/> AC	<input type="checkbox"/> DC (12V)	<input type="checkbox"/> AIR/OIL
MOTOR VOLTAGE	<input type="checkbox"/> 115	<input type="checkbox"/> 208	<input checked="" type="checkbox"/> 460
DEDICATED CIRCUIT REQUIRED 60Hz			
MOTOR PHASE	<input type="checkbox"/> SINGLE	<input checked="" type="checkbox"/> THREE	
CONTROL	<input checked="" type="checkbox"/> HAND	<input type="checkbox"/> FOOT	

NOTE: EHTT MUST BE ANCHORED TO FLOOR

DIMENSION TOLERANCE $\pm 1/4$ "

STANDARD FEATURES

- MODEL NUMBER: EHTT
- CAPACITY: 4,000 LBS. EVENLY DISTRIBUTED
- PLATFORM WIDTH: 48"
- PLATFORM LENGTH: 47 3/4"
- LEVEL HEIGHT: 10"
- LIP HEIGHT: 12"
- MAXIMUM TILT ANGLE: 45°
- DOUBLE ACTING HYDRAULIC CYLINDER
- W/ DOWN VELOCITY FUSE
- INTERNAL POWER UNIT
- 24 V HAND CONTROL ON 8 FT. COIL CORD
- UPPER & LOWER TILT LIMIT SWITCHES
- DURABLE LIQUID PAINT BLUE FINISH
- 4- Ø5/8" MOUNTING HOLES

SPECIAL FEATURES

NONE

APPROVAL

I, THE UNDERSIGNED, AGREE THAT THE PRODUCT AS REPRESENTED SATISFIES DESIGN AND DIMENSION REQUIREMENTS. I ALSO ACKNOWLEDGE MY DUTY TO CONFIRM PRODUCT AND INSTALLATION COMPLIANCE WITH ALL APPLICABLE FEDERAL, STATE AND LOCAL REGULATIONS AND STANDARDS.

ANY MODIFIED UNITS ARE NON-RETURNABLE

[] As drawn [] As marked

Signed: _____ Date: _____

Printed Name: _____

LEAD TIME WILL START UPON RECEIPT OF SIGNED APPROVAL DRAWING

FOR INTERNAL USE ONLY
 PROJECT SIGN OFF

SALES	
ENG.	
FAB.	
POWER	

DISTRIBUTOR'S NAME:		P.O.#
VESTIL MANUFACTURING		X
DRAWN BY: CRA	DATE: 03/20/2019	W.O.#
REFERENCE: X	SCALE: 1:20	X
QUOTED LEAD TIME: X	QUOTE #	FILE NAME:
	X	38-007-005