

# LIFT AND TILT SCISSOR TABLE - EHLTT-4848-5-47

APPROX WEIGHT: 1502.05 lbs.  
DOES NOT INCLUDE WEIGHT OF POWER OR PACKAGING!!!

\*\*\* ANY ADDITIONS, DELETIONS, OR OMISSIONS MUST BE CORRECTED ON THIS DRAWING AS THIS DRAWING WILL BE CONSIDERED ALL INCLUSIVE \*\*\*

ALL GRAPHICS PROVIDED ARE FOR REFERENCE ONLY. IF CERTAIN DIMENSIONS ARE CRITICAL PLEASE VERIFY THOSE DIMENSIONS WITH YOUR SALESPERSON

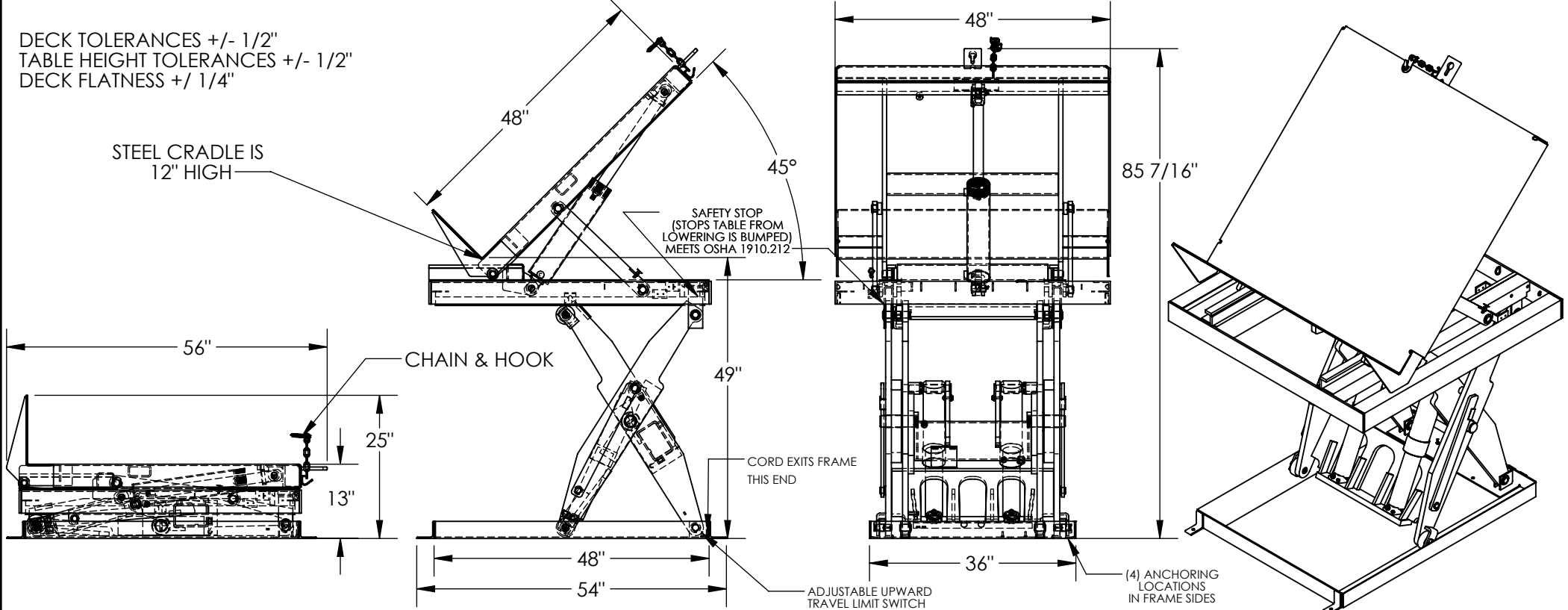

## STANDARD FEATURES

- MODEL NUMBER IS EHLTT-4848-5-47
- MAX CAPACITY IS 5,000 LBS
- PLATFORM WIDTH IS 48"
- FRAME WIDTH IS 36"
- OVERALL LENGTH IS 56"
- PLATFORM LENGTH IS 48"
- PLATFORM RAISED HEIGHT IS 49"
- PLATFORM LOWERED HEIGHT IS 13"
- OVERALL HEIGHT IS 85 7/16"
- PLATFORM TILTS ON THE END OF THE LEG ASSEMBLY
- PLATFORM TILTING STYLE IS A SLIDE TILT
- Ø1/4" x 60" CHAIN AND HOOK (NOT DRAWN TO SCALE)
- MAXIMUM TILT ANGLE IS 45°
- INTERNAL POWER UNIT
- CONTROL IS HANDHELD, 4 BUTTON, NEMA 4 PENDANT WITH MINIMUM 8' USABLE COIL CORD
- DURABLE LIQUID PAINT BLUE FINISH

## PLEASE CIRCLE SPECIFICATIONS:

POWER	<input checked="" type="checkbox"/> AC	* <input type="checkbox"/> DC	* <input type="checkbox"/> AIR/OIL
MOTOR VOLTAGE	<input type="checkbox"/> 115	<input type="checkbox"/> 208	<input checked="" type="checkbox"/> 230
DEDICATED CIRCUIT REQUIRED			
MOTOR PHASE	<input type="checkbox"/> SINGLE	<input checked="" type="checkbox"/> THREE	
CONTROL	<input checked="" type="checkbox"/> HAND	* <input type="checkbox"/> FOOT	
~ ALL BATTERY CHARGERS ARE 115V AC ~			
* BATTERY CHRG.	<input checked="" type="checkbox"/> REMOTE	<input type="checkbox"/> ON BOARD	
* CHRG. INDICATOR	<input type="checkbox"/> YES	<input checked="" type="checkbox"/> NO	

\* AVAILABLE AT ADDITIONAL COST

## SPECIAL FEATURES

NONE

APPROVAL

I, THE UNDERSIGNED, AGREE THAT THE PRODUCT AS REPRESENTED SATISFIES DESIGN AND DIMENSION REQUIREMENTS. I ALSO ACKNOWLEDGE MY DUTY TO CONFIRM PRODUCT AND INSTALLATION COMPLIANCE WITH ALL APPLICABLE FEDERAL, STATE AND LOCAL REGULATIONS AND STANDARDS.

**UNITS REQUIRING APPROVAL DRAWINGS OR MODIFIED ARE NON-RETURNABLE**

[ ] As drawn [ ] As marked

Signed: \_\_\_\_\_ Date: \_\_\_\_\_

Printed Name: \_\_\_\_\_

LEAD TIME WILL START UPON RECEIPT OF SIGNED APPROVAL DRAWING

DISTRIBUTOR'S NAME:		P.O.#
VESTIL MANUFACTURING		X
DRAWN BY: BCN		W.O.#
DATE: 3/8/2018		X
REFERENCE: X	SCALE: 1:25	SALES: X
QUOTED LEAD TIME: X	QUOTE #	FILE NAME:
	X	02-007-301