

SHORTY SCISSOR LIFT TABLE - EHLTS-2436-2-31

APPROX WEIGHT: 450.49 lbs.
DOES NOT INCLUDE WEIGHT OF POWER OR PACKAGING!!!

*** ANY ADDITIONS, DELETIONS, OR OMISSIONS MUST BE CORRECTED ON THIS DRAWING AS THIS DRAWING WILL BE CONSIDERED ALL INCLUSIVE ***

ALL GRAPHICS PROVIDED ARE FOR REFERENCE ONLY. IF CERTAIN DIMENSIONS ARE CRITICAL PLEASE VERIFY THOSE DIMENSIONS WITH YOUR SALESPERSON

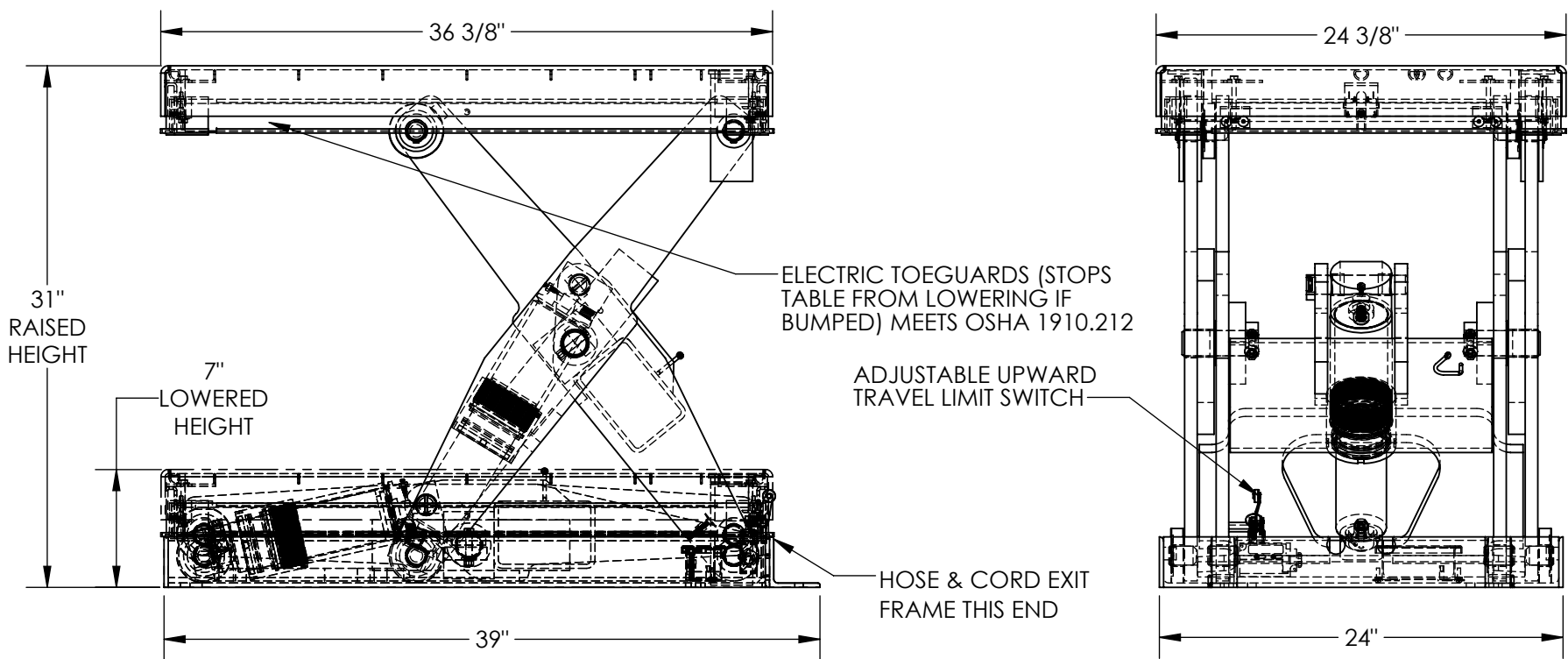

STANDARD FEATURES

- MODEL NUMBER IS EHLTS-2436-2-31
- PLATFORM WIDTH IS: 24 3/8"
- PLATFORM LENGTH IS: 36 3/8"
- PLATFORM RAISED HEIGHT IS: 31"
- PLATFORM LOWERED HEIGHT IS: 7"
- TABLE CAPACITY (EVENLY DISTRIBUTED) LOAD IS 2,000 LBS
- STANDARD CONTROL IS 24 VOLT
- CONTROL IS HANDHELD, 2 BUTTON, NEMA 4 PENDANT WITH MINIMUM 8' USABLE COIL CORD
- DISPLACEMENT STYLE CYLINDERS
- INSTALLED ROD DOWN
- EMERGENCY SAFETY STOP HYDRAULIC FUSES IN ALL CYLINDERS UNITS HAVE 2' TEST LEAD AND PIG TAIL
- EXTERNAL POWER UNIT
- DURABLE LIQUID PAINT BLUE FINISH

SPECIAL FEATURES

NONE

REMOTE POWER UNIT
32 1/2" x 12" 12 1/2" (L x W x H)
WITH 8' HOSE & CABLE



PLEASE CIRCLE SPECIFICATIONS:

POWER	AC	DC (12V)	AIR/OIL
MOTOR VOLTAGE	115	208	230 460
DEDICATED CIRCUIT REQUIRED 60HZ			
MOTOR PHASE	SINGLE	THREE	
CONTROL	HAND	FOOT	

DECK TOLERANCE ± 1/2"
TABLE HEIGHT TOLERANCE ± 1/2"
DECK FLATNESS ± 1/4" DIMENSION TOLERANCE ± 1/4"

A P P R O V A L

I, THE UNDERSIGNED, AGREE THAT THE PRODUCT AS REPRESENTED SATISFIES DESIGN AND DIMENSION REQUIREMENTS. I ALSO ACKNOWLEDGE MY DUTY TO CONFIRM PRODUCT AND INSTALLATION COMPLIANCE WITH ALL APPLICABLE FEDERAL, STATE AND LOCAL REGULATIONS AND STANDARDS.

UNITS REQUIRING APPROVAL DRAWINGS OR MODIFIED ARE NON-RETURNABLE

[] As drawn [] As marked

Signed: _____ Date: _____

Printed Name: _____

LEAD TIME WILL START UPON RECEIPT OF SIGNED APPROVAL DRAWING

DISTRIBUTOR'S NAME:		P.O.#
VESTIL MANUFACTURING		X
DRAWN BY: KEC		W.O.#
DATE: 9/30/16		X
REFERENCE: X	SCALE: 1:10	SALES: X
QUOTED LEAD TIME: X	QUOTE # X	FILE NAME:
		01-007-201-001