

SCISSOR GROUND LIFT AND TILT - EHLTGT-4452-2-36

APPROX WEIGHT: 2099 lbs.
DOES NOT INCLUDE WEIGHT OF POWER OR PACKAGING!!!

*** ANY ADDITIONS, DELETIONS, OR OMISSIONS MUST BE CORRECTED ON THIS DRAWING AS THIS DRAWING WILL BE CONSIDERED ALL INCLUSIVE ***

ALL GRAPHICS PROVIDED ARE FOR REFERENCE ONLY. IF CERTAIN DIMENSIONS ARE CRITICAL PLEASE VERIFY THOSE DIMENSIONS WITH YOUR SALESPERSON

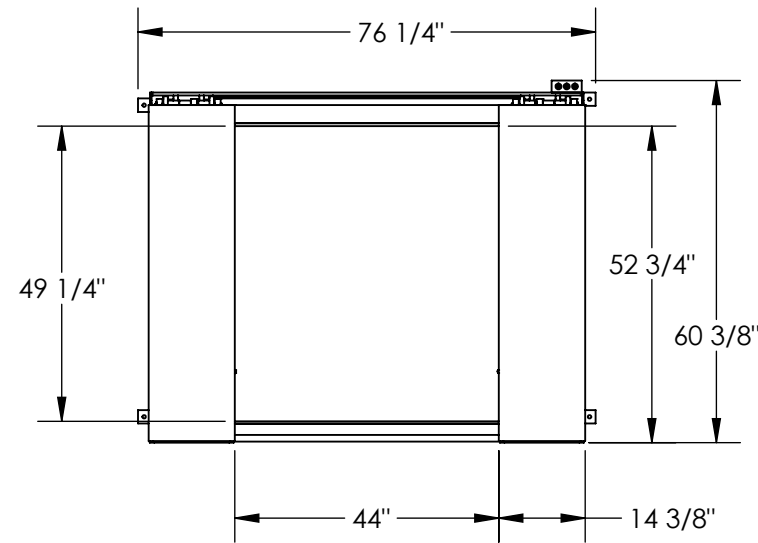
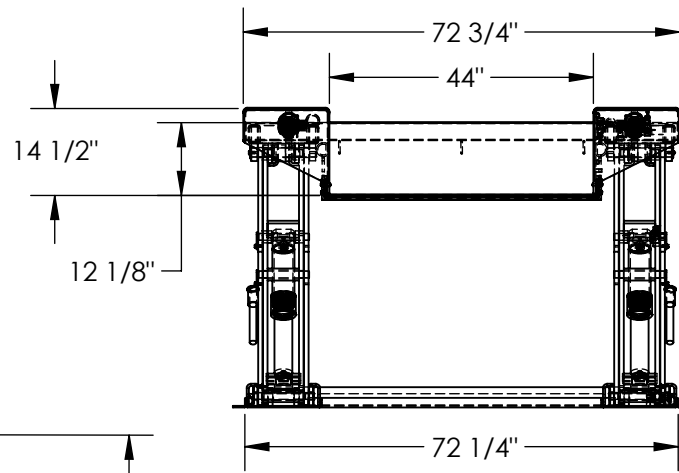
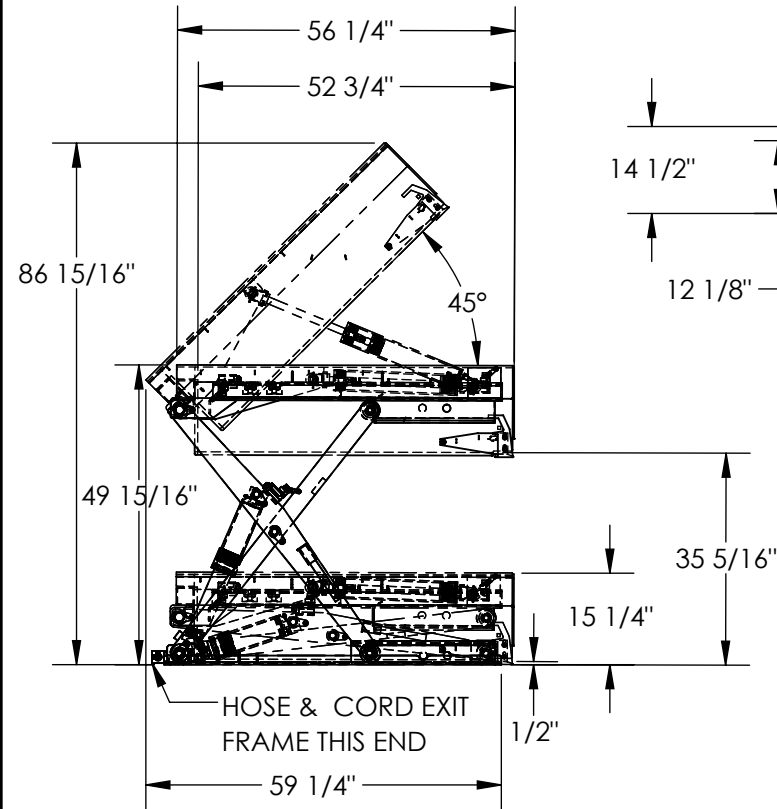

REMOTE POWER UNIT
24 1/2" x 22 1/2" x 7 1/2" (L x W x H)
WITH 8' HOSE & CABLE

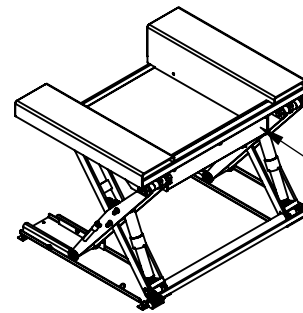
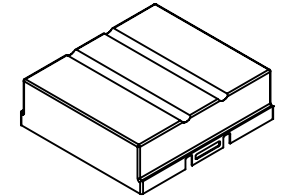

12" HIGH BACK PLATE

DIMENSION TOLERANCE ± 1/4"

STANDARD FEATURES

- MODEL NUMBER IS EHLTGT-4452-2-36
- OVERALL WIDTH IS 72 3/4"
- USABLE WIDTH IS 44"
- OVERALL LENGTH IS 56 1/4"
- USABLE LENGTH IS 52 3/4"
- OVERALL HEIGHT IS 49 15/16"
- PLATFORM RAISED HEIGHT IS 35 5/16"
- PLATFORM LOWERED HEIGHT IS 1/2"
- MAX CAPACITY IS 2,000 LB
- DURABLE LIQUID PAINT BLUE FINISH
- CONTROL IS HANDHELD, 4 BUTTON, NEMA 4
- PENDANT WITH MINIMUM 8' USABLE COIL CORD
- EXTERNAL POWER UNIT

PLEASE CIRCLE SPECIFICATIONS:

POWER	AC	DC (12V)	AIR/OIL
MOTOR VOLTAGE	115	208	230 460
DEDICATED CIRCUIT REQUIRED 60Hz			
MOTOR PHASE	SINGLE	THREE	
CONTROL	HAND	FOOT	

SPECIAL FEATURES

NONE

APPROVAL

I, THE UNDERSIGNED, AGREE THAT THE PRODUCT AS REPRESENTED SATISFIES DESIGN AND DIMENSION REQUIREMENTS. I ALSO ACKNOWLEDGE MY DUTY TO CONFIRM PRODUCT AND INSTALLATION COMPLIANCE WITH ALL APPLICABLE FEDERAL, STATE AND LOCAL REGULATIONS AND STANDARDS.

UNITS REQUIRING APPROVAL DRAWINGS OR MODIFIED ARE NON-RETURNABLE

[] As drawn [] As marked

Signed: _____ Date: _____

Printed Name: _____

LEAD TIME WILL START UPON RECEIPT OF SIGNED APPROVAL DRAWING

DISTRIBUTOR'S NAME:		P.O.#
VESTIL MANUFACTURING		X
DRAWN BY: ABR		W.O.#
DATE: 8/2/19		X
REFERENCE: X	SCALE: 1:32	SALES: X
QUOTED LEAD TIME: X	QUOTE #	FILE NAME:
	X	04-007-104