

GROUND LIFT SCISSOR TABLE - EHLTG-5284-3-54

APPROX WEIGHT: 2683.75 lbs.
 DOES NOT INCLUDE WEIGHT OF POWER OR PACKAGING!!!

*** ANY ADDITIONS, DELETIONS, OR OMISSIONS MUST BE CORRECTED ON THIS DRAWING AS THIS DRAWING WILL BE CONSIDERED ALL INCLUSIVE ***

ALL GRAPHICS PROVIDED ARE FOR REFERENCE ONLY. IF CERTAIN DIMENSIONS ARE CRITICAL PLEASE VERIFY THOSE DIMENSIONS WITH YOUR SALESPERSON

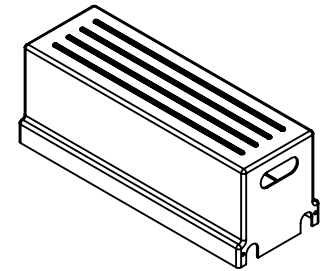
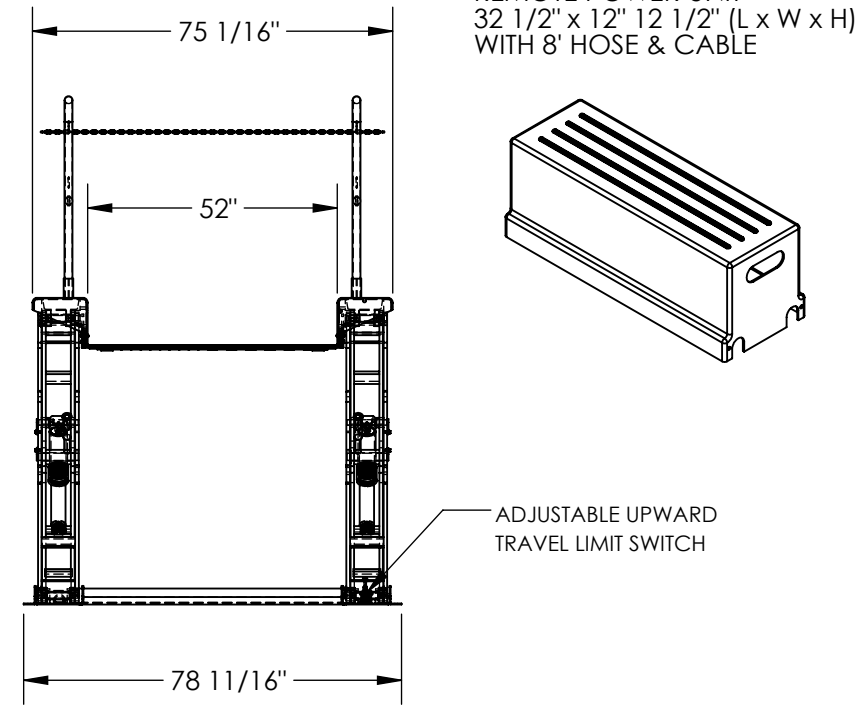
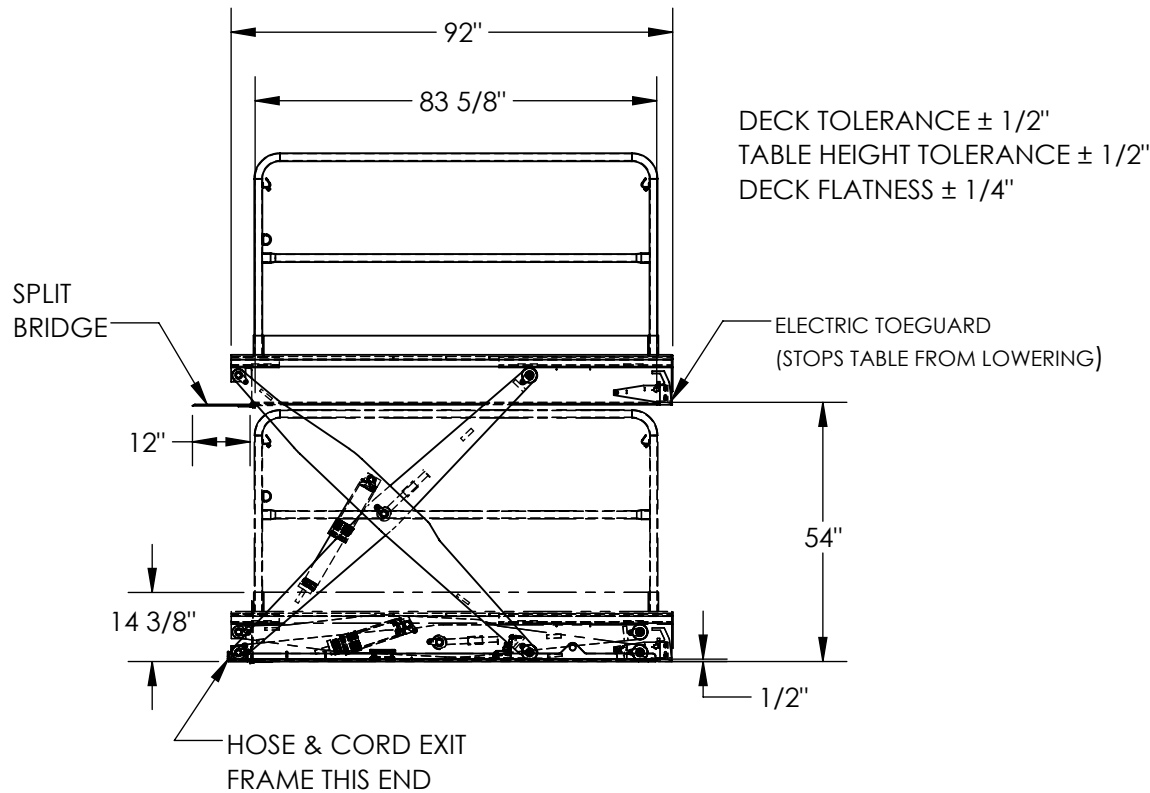

STANDARD FEATURES

- MODEL NUMBER IS EHLTG-5284-3-54
- OVERALL WIDTH IS 78 11/16"
- USABLE WIDTH IS 52"
- OVERALL LENGTH IS 92"
- USABLE LENGTH IS 83 5/8"
- RAISED HEIGHT IS 54"
- LOWERED HEIGHT IS 1/2"
- 12" WIDE BY 52" LONG SLIT BRIDGE
- TABLE CAPACITY (EVENLY DISTRIBUTED) IS 3,000 LBS.
- EXTERNAL POWER UNIT
- NON-REMOVABLE TOE BOARDS
- SAFETY MAINTENANCE PROPS
- DISPLACEMENT STYLE CYLINDERS
- INSTALLED ROD DOWN
- EMERGENCY SAFETY STOP HYDRAULIC FUSES IN ALL CYLINDERS
- UNITS HAVE 2' TEST LEAD AND PIG TAIL
- CONTROL IS FOOT SWITCH, 2 PEDAL, NEMA 1 WITH MINIMUM USABLE 8' STRAIGHT CORD
- DURABLE LIQUID PAINT BLUE FINISH WITH TOUGH BAKED IN POWDER COATED YELLOW FINISH REMOVABLE HAND RAILS

PLEASE CIRCLE SPECIFICATIONS:

POWER	AC	DC (12V)	AIR/OIL
MOTOR VOLTAGE	115	208	230 460
DEDICATED CIRCUIT REQUIRED 60Hz			
MOTOR PHASE	SINGLE	THREE	
CONTROL	HAND	FOOT	

SPECIAL FEATURES

NONE

DIMENSION TOLERANCE ± 1/4"

APPROVAL

I, THE UNDERSIGNED, AGREE THAT THE PRODUCT AS REPRESENTED SATISFIES DESIGN AND DIMENSION REQUIREMENTS. I ALSO ACKNOWLEDGE MY DUTY TO CONFIRM PRODUCT AND INSTALLATION COMPLIANCE WITH ALL APPLICABLE FEDERAL, STATE AND LOCAL REGULATIONS AND STANDARDS.
UNITS REQUIRING APPROVAL DRAWINGS OR MODIFIED ARE NON-RETURNABLE
 As drawn As marked

Signed: _____ Date: _____

Printed Name: _____

LEAD TIME WILL START UPON RECEIPT OF SIGNED APPROVAL DRAWING

DISTRIBUTOR'S NAME:		P.O.#
VESTIL MANUFACTURING		X
DRAWN BY:	DATE:	W.O.#
JWW	8/15/19	X
REFERENCE:	SCALE:	SALES:
X	1:40	X
QUOTED LEAD TIME:	QUOTE #	FILE NAME:
X	X	04-007-114