

GROUND LIFT SCISSOR TABLE - EHLTG-4450-4-36

APPROX WEIGHT: 1320.20 lbs.
 DOES NOT INCLUDE WEIGHT OF POWER OR PACKAGING!!!

*** ANY ADDITIONS, DELETIONS, OR OMISSIONS MUST BE CORRECTED ON THIS DRAWING AS THIS DRAWING WILL BE CONSIDERED ALL INCLUSIVE ***

ALL GRAPHICS PROVIDED ARE FOR REFERENCE ONLY. IF CERTAIN DIMENSIONS ARE CRITICAL PLEASE VERIFY THOSE DIMENSIONS WITH YOUR SALESPERSON

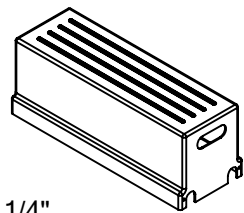
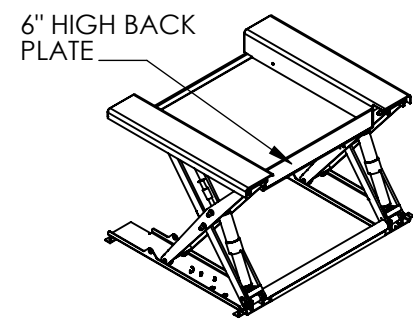
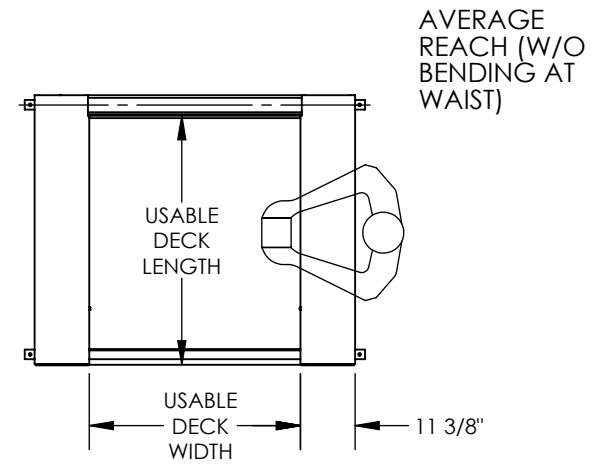
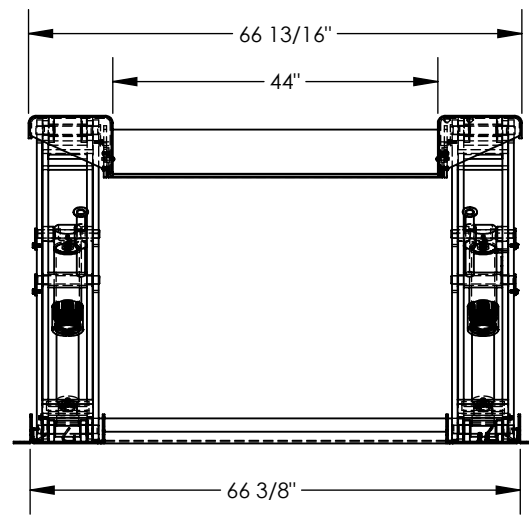
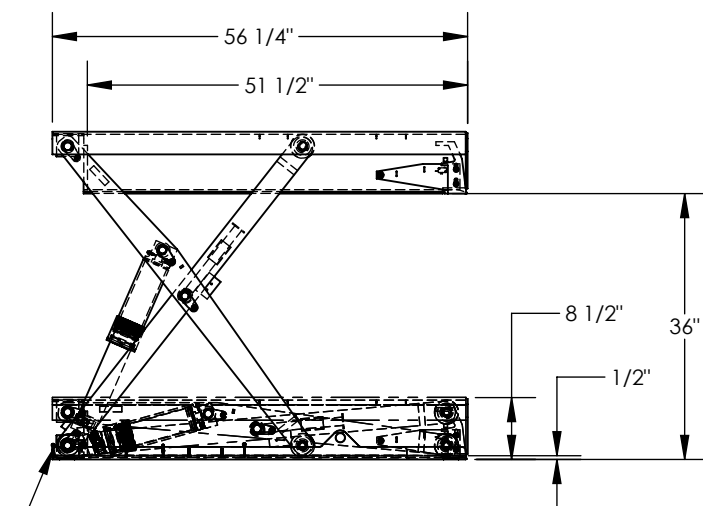

REMOTE POWER UNIT:
 32 1/2" x 12" x 12 1/2"
 (L x W x H)
 WITH 8' HOSE & CABLE

DIMENSION TOLERANCE ± 1/4"

STANDARD FEATURES

MODEL NUMBER IS: EHLTG-4450-4-36
 PLATFORM WIDTH (USABLE): 44"
 PLATFORM LENGTH (USABLE): 51 1/2"
 OVERALL WIDTH: 66 13/16"
 OVERALL LENGTH: 56 1/4"
 PLATFORM RAISED HEIGHT: 36"
 PLATFORM LOWERED HEIGHT: 1/2"
 CAPACITY: 4,000 LBS.
 EXTERNAL POWER UNIT
 CONTROL IS FOOT SWITCH, 2 PEDAL, NEMA 1
 WITH MINIMUM USABLE 8' STRAIGHT CORD
 DURABLE LIQUID PAINT BLUE FINISH

SPECIAL FEATURES

NONE

PLEASE CIRCLE SPECIFICATIONS:

POWER	<input checked="" type="checkbox"/> AC	<input type="checkbox"/> DC (12V)	<input type="checkbox"/> AIR/OIL
MOTOR VOLTAGE	<input type="checkbox"/> 115	<input type="checkbox"/> 208	<input checked="" type="checkbox"/> 230
DEDICATED CIRCUIT REQUIRED 60Hz			
MOTOR PHASE	<input type="checkbox"/> SINGLE	<input checked="" type="checkbox"/> THREE	
CONTROL	<input type="checkbox"/> HAND	<input checked="" type="checkbox"/> FOOT	

APPROVAL

I, THE UNDERSIGNED, AGREE THAT THE PRODUCT AS REPRESENTED SATISFIES DESIGN AND DIMENSION REQUIREMENTS. I ALSO ACKNOWLEDGE MY DUTY TO CONFIRM PRODUCT AND INSTALLATION COMPLIANCE WITH ALL APPLICABLE FEDERAL, STATE AND LOCAL REGULATIONS AND STANDARDS.
UNITS REQUIRING APPROVAL DRAWINGS OR MODIFIED ARE NON-RETURNABLE
 As drawn As marked

Signed: _____ Date: _____

Printed Name: _____

LEAD TIME WILL START UPON RECEIPT OF SIGNED APPROVAL DRAWING

DISTRIBUTOR'S NAME:		P.O.#
VESTIL MANUFACTURING		X
DRAWN BY:	DATE:	W.O.#
V.GONI	08/06/2013	X
REFERENCE:	SCALE:	FILE NAME:
X	1:26	
QUOTED LEAD TIME:	QUOTE #	
X	X	04-007-054