

GROUND LIFT SCISSOR TABLE - EHLTG-4450-2-36

APPROX WEIGHT: 1299.70 lbs.
 DOES NOT INCLUDE WEIGHT OF POWER OR PACKAGING!!!

*** ANY ADDITIONS, DELETIONS, OR OMISSIONS MUST BE CORRECTED ON THIS DRAWING AS THIS DRAWING WILL BE CONSIDERED ALL INCLUSIVE ***

ALL GRAPHICS PROVIDED ARE FOR REFERENCE ONLY. IF CERTAIN DIMENSIONS ARE CRITICAL PLEASE VERIFY THOSE DIMENSIONS WITH YOUR SALESPERSON

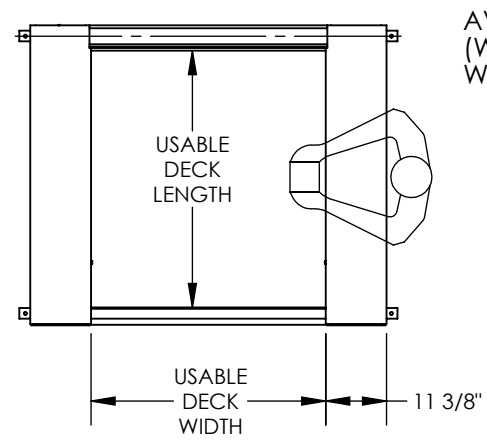
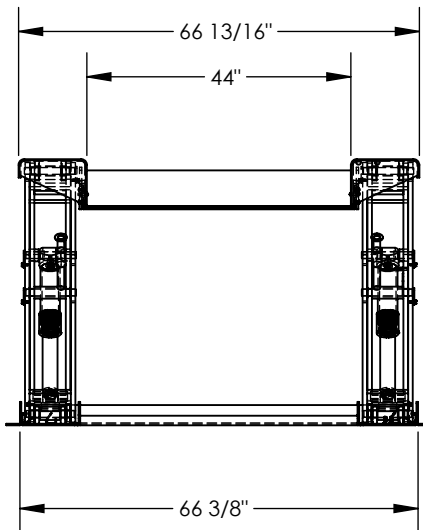
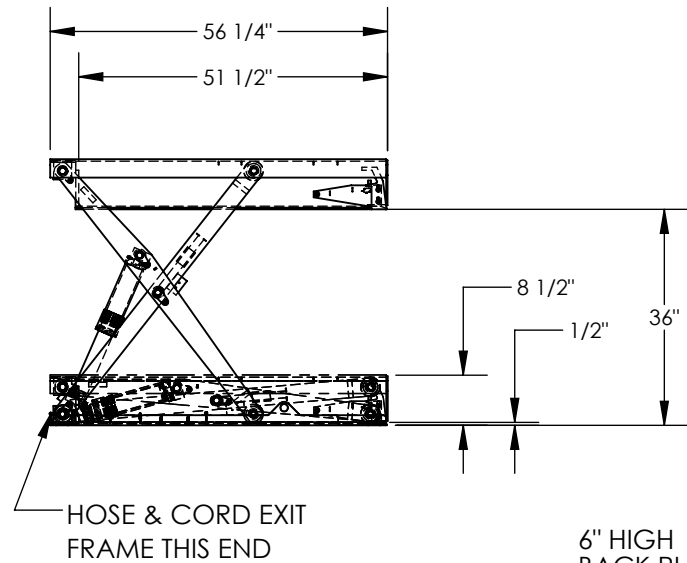

AVERAGE REACH
(W/O BENDING AT
WAIST)

6" HIGH
BACK PLATE

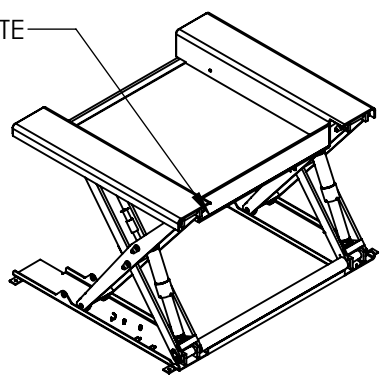

REMOTE POWER UNIT
 32 1/2" x 12" 12 1/2" (L x W x H)
 WITH 8' HOSE & CABLE

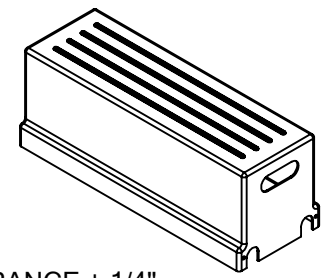

STANDARD FEATURES

- MODEL NUMBER IS: EHLTG-4450-2-36
- PLATFORM WIDTH (USABLE): 44"
- PLATFORM LENGTH (USABLE): 51 1/2"
- OVERALL WIDTH: 66 13/16"
- OVERALL LENGTH: 56 1/4"
- PLATFORM RAISED HEIGHT: 36"
- PLATFORM LOWERED HEIGHT: 1/2"
- CAPACITY: 2,000 LBS.
- EXTERNAL POWER UNIT
- CONTROL IS FOOT SWITCH, 2 PEDAL, NEMA 1
- WITH MINIMUM USABLE 8' STRAIGHT CORD
- DURABLE LIQUID PAINT BLUE FINISH

SPECIAL FEATURES

NONE

PLEASE CIRCLE SPECIFICATIONS:

POWER	<input checked="" type="checkbox"/> AC	<input type="checkbox"/> DC (12V)	<input type="checkbox"/> AIR/OIL
MOTOR VOLTAGE	<input type="checkbox"/> 115	<input type="checkbox"/> 208	<input checked="" type="checkbox"/> 230 460
DEDICATED CIRCUIT REQUIRED 60Hz			
MOTOR PHASE	<input type="checkbox"/> SINGLE	<input checked="" type="checkbox"/> THREE	
CONTROL	<input type="checkbox"/> HAND	<input checked="" type="checkbox"/> FOOT	

DIMENSION TOLERANCE ± 1/4"

APPROVAL

I, THE UNDERSIGNED, AGREE THAT THE PRODUCT AS REPRESENTED SATISFIES DESIGN AND DIMENSION REQUIREMENTS. I ALSO ACKNOWLEDGE MY DUTY TO CONFIRM PRODUCT AND INSTALLATION COMPLIANCE WITH ALL APPLICABLE FEDERAL, STATE AND LOCAL REGULATIONS AND STANDARDS.

UNITS REQUIRING APPROVAL DRAWINGS OR MODIFIED ARE NON-RETURNABLE

[] As drawn [] As marked

Signed: _____ Date: _____

Printed Name: _____

LEAD TIME WILL START UPON RECEIPT OF SIGNED APPROVAL DRAWING

DISTRIBUTOR'S NAME:		P.O.#
VESTIL MANUFACTURING		X
DRAWN BY: V.GONI		DATE: 10/02/2013
REFERENCE: X		SCALE: 1:32
QUOTED LEAD TIME: X		QUOTE # X
		SALES: X
		FILE NAME: 04-007-051