

GROUND LIFT SCISSOR TABLE - EHLTG-4450-2-36-PSS

APPROX WEIGHT: 1322.42 lbs.
 DOES NOT INCLUDE WEIGHT OF POWER OR PACKAGING!!!

*** ANY ADDITIONS, DELETIONS, OR OMISSIONS MUST BE CORRECTED ON THIS DRAWING AS THIS DRAWING WILL BE CONSIDERED ALL INCLUSIVE ***

ALL GRAPHICS PROVIDED ARE FOR REFERENCE ONLY. IF CERTAIN DIMENSIONS ARE CRITICAL PLEASE VERIFY THOSE DIMENSIONS WITH YOUR SALESPERSON

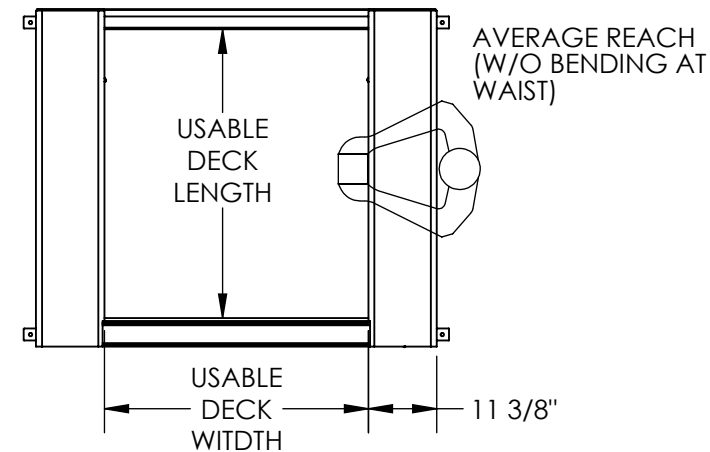
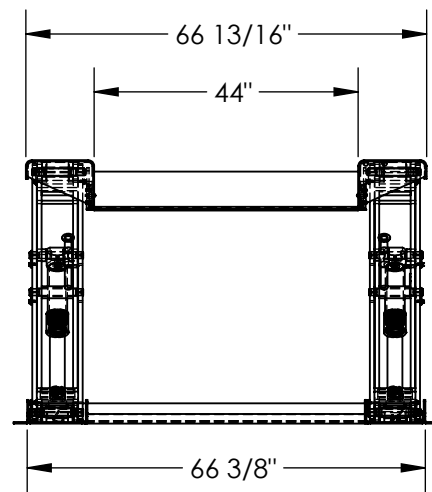
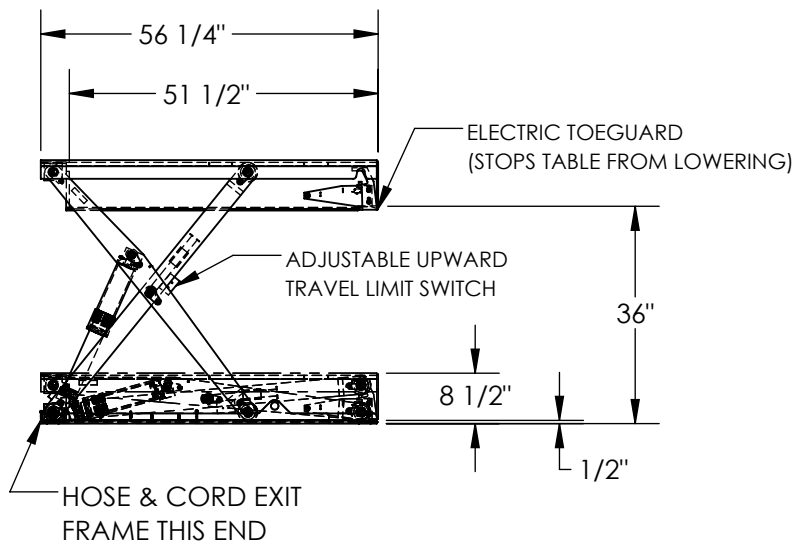

DECK TOLERANCE $\pm 1/2$ "
 TABLE HEIGHT TOLERANCE $\pm 1/2$ "
 DECK FLATNESS $\pm 1/4$ "

6" HIGH
 BACK PLATE

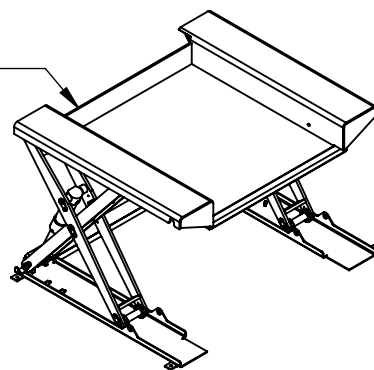

REMOTE POWER UNIT
 32 1/2" x 12" x 12 1/2" (L x W x H)
 WITH 8' HOSE & CABLE

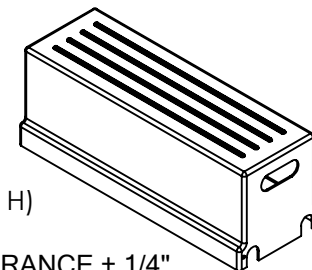

DIMENSION TOLERANCE $\pm 1/4$ "

STANDARD FEATURES

- MODEL NUMBER IS EHLTG-4450-2-36-PSS
- USABLE WIDTH IS 44"
- USABLE LENGTH IS 51 1/2"
- OVERALL WIDTH IS 66 13/16"
- OVERALL LENGTH IS 56 1/4"
- RAISED HEIGHT IS 36"
- LOWERED HEIGHT IS 1 1/2"
- TABLE CAPACITY (EVENLY DISTRIBUTED) IS 2000 LBS.
- EXTERNAL POWER UNIT
- SAFETY MAINTENANCE PROPS
- DISPLACEMENT STYLE CYLINDERS
- INSTALLED ROD DOWN
- EMERGENCY SAFETY STOP HYDRAULIC FUSES IN ALL CYLINDERS
- UNITS HAVE 2' TEST LEAD AND PIG TAIL
- CONTROL IS FOOT SWITCH, 2 PEDAL, NEMA 1 WITH MINIMUM USABLE 8' STRAIGHT CORD
- STAINLESS STEEL DECK AND FRAME
- SCISSOR LEGS ARE HOT DIP GALVANIZED

PLEASE CIRCLE SPECIFICATIONS:

POWER	AC	DC (12V)	AIR/OIL
MOTOR VOLTAGE	115	208	230 460
DEDICATED CIRCUIT REQUIRED 60Hz			
MOTOR PHASE	SINGLE	THREE	
CONTROL	HAND	FOOT	

APPROVAL

I, THE UNDERSIGNED, AGREE THAT THE PRODUCT AS REPRESENTED SATISFIES DESIGN AND DIMENSION REQUIREMENTS. I ALSO ACKNOWLEDGE MY DUTY TO CONFIRM PRODUCT AND INSTALLATION COMPLIANCE WITH ALL APPLICABLE FEDERAL, STATE AND LOCAL REGULATIONS AND STANDARDS.

UNITS REQUIRING APPROVAL DRAWINGS OR MODIFIED ARE NON-RETURNABLE

[] As drawn [] As marked

Signed: _____ Date: _____

Printed Name: _____

LEAD TIME WILL START UPON RECEIPT OF SIGNED APPROVAL DRAWING

DISTRIBUTOR'S NAME:		P.O.#
VESTIL MANUFACTURING		X
DRAWN BY: RLH		W.O.#
DATE: 8/3/18		X
REFERENCE: X	SCALE: 1:32	SALES: X
QUOTED LEAD TIME: X	QUOTE # X	FILE NAME:
		04-007-058

SPECIAL FEATURES

NONE