

# GROUND LIFT SCISSOR TABLE - EHLTG-3850-4-36

APPROX WEIGHT: 1256.76 lbs.  
 DOES NOT INCLUDE WEIGHT OF POWER OR PACKAGING!!!

\*\*\* ANY ADDITIONS, DELETIONS, OR OMISSIONS MUST BE CORRECTED ON THIS DRAWING AS THIS DRAWING WILL BE CONSIDERED ALL INCLUSIVE \*\*\*

ALL GRAPHICS PROVIDED ARE FOR REFERENCE ONLY. IF CERTAIN DIMENSIONS ARE CRITICAL PLEASE VERIFY THOSE DIMENSIONS WITH YOUR SALESPERSON

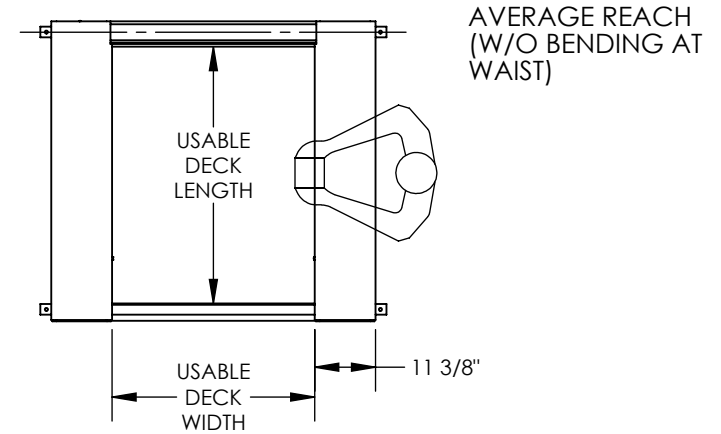
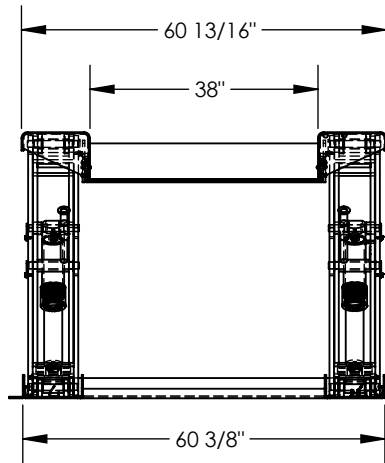
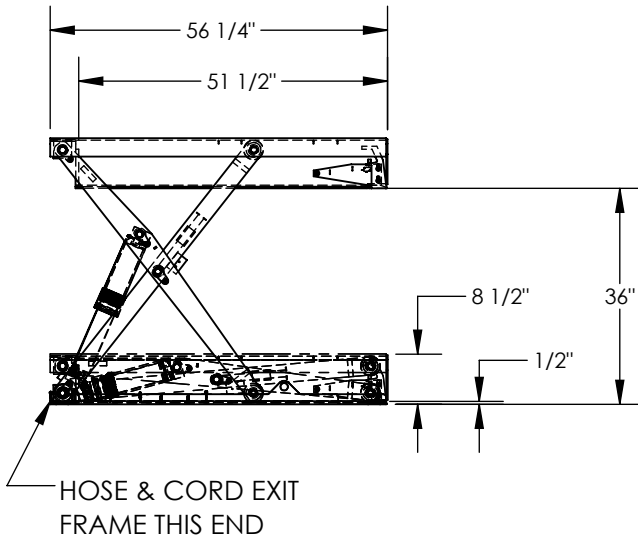

AVERAGE REACH  
(W/O BENDING AT  
WAIST)

6" HIGH  
BACK PLATE

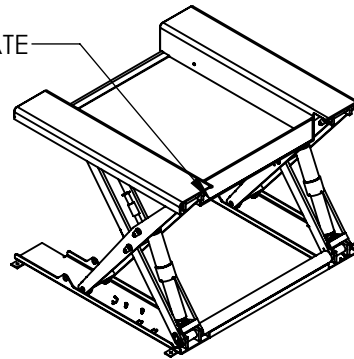

REMOTE POWER UNIT  
 32 1/2" x 12" 12 1/2" (L x W x H)  
 WITH 8' HOSE & CABLE

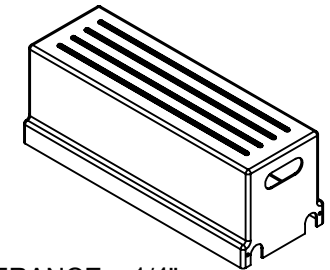

DIMENSION TOLERANCE ± 1/4"

## STANDARD FEATURES

MODEL NUMBER IS: EHLTG-3850-4-36  
 PLATFORM WIDTH (USABLE): 38"  
 PLATFORM LENGTH (USABLE): 51 1/2"  
 OVERALL WIDTH: 60 13/16"  
 OVERALL LENGTH: 56 1/4"  
 PLATFORM RAISED HEIGHT: 36"  
 PLATFORM LOWERED HEIGHT: 1/2"  
 EXTERNAL POWER UNIT  
 CAPACITY: 4,000 LBS.  
 DURABLE LIQUID PAINT BLUE FINISH  
 CONTROL IS FOOT SWITCH, 2 PEDAL, NEMA 1  
 WITH MINIMUM USABLE 8' STRAIGHT CORD

## PLEASE CIRCLE SPECIFICATIONS:

POWER	<input checked="" type="checkbox"/> AC	<input type="checkbox"/> DC (12V)	<input type="checkbox"/> AIR/OIL
MOTOR VOLTAGE	<input type="checkbox"/> 115	<input type="checkbox"/> 200	<input checked="" type="checkbox"/> 230 <input type="checkbox"/> 460
DEDICATED CIRCUIT REQUIRED 60Hz			
MOTOR PHASE	<input type="checkbox"/> SINGLE	<input checked="" type="checkbox"/> THREE	
CONTROL	<input type="checkbox"/> HAND	<input checked="" type="checkbox"/> FOOT	

## SPECIAL FEATURES

NONE

APPROVAL

I, THE UNDERSIGNED, AGREE THAT THE PRODUCT AS REPRESENTED SATISFIES DESIGN AND DIMENSION REQUIREMENTS. I ALSO ACKNOWLEDGE MY DUTY TO CONFIRM PRODUCT AND INSTALLATION COMPLIANCE WITH ALL APPLICABLE FEDERAL, STATE AND LOCAL REGULATIONS AND STANDARDS.  
**UNITS REQUIRING APPROVAL DRAWINGS OR MODIFIED ARE NON-RETURNABLE**

[ ] As drawn [ ] As marked

Signed: \_\_\_\_\_ Date: \_\_\_\_\_

Printed Name: \_\_\_\_\_

LEAD TIME WILL START UPON RECEIPT OF SIGNED APPROVAL DRAWING

DISTRIBUTOR'S NAME:		P.O.#	
VESTIL MANUFACTURING		X	
DRAWN BY: JWW		DATE: 10/02/2013	W.O.#
REFERENCE: X		SCALE: 1:32	X
QUOTED LEAD TIME: X		QUOTE #	SALES: X
		X	FILE NAME:
			04-007-102