

GROUND LIFT SCISSOR TABLE - EHLTG-3850-2-36

APPROX WEIGHT: 1236.31 lbs.
DOES NOT INCLUDE WEIGHT OF POWER OR PACKAGING!!!

*** ANY ADDITIONS, DELETIONS, OR OMISSIONS MUST BE CORRECTED ON THIS DRAWING AS THIS DRAWING WILL BE CONSIDERED ALL INCLUSIVE ***

ALL GRAPHICS PROVIDED ARE FOR REFERENCE ONLY. IF CERTAIN DIMENSIONS ARE CRITICAL PLEASE VERIFY THOSE DIMENSIONS WITH YOUR SALESPERSON

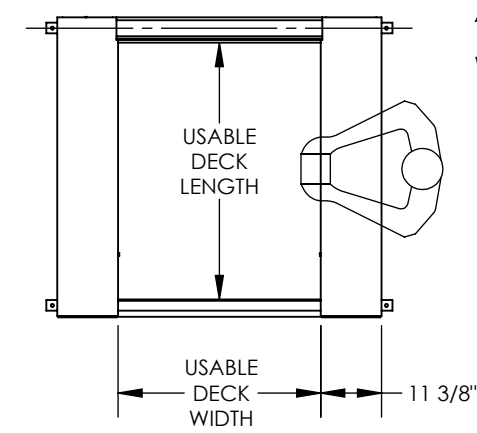
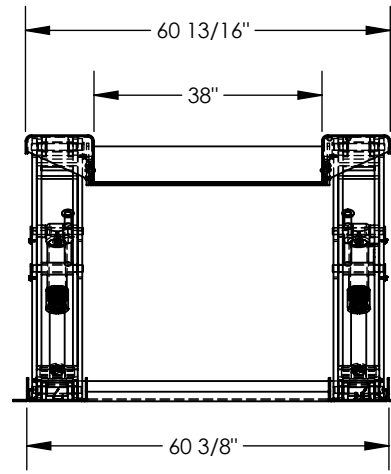
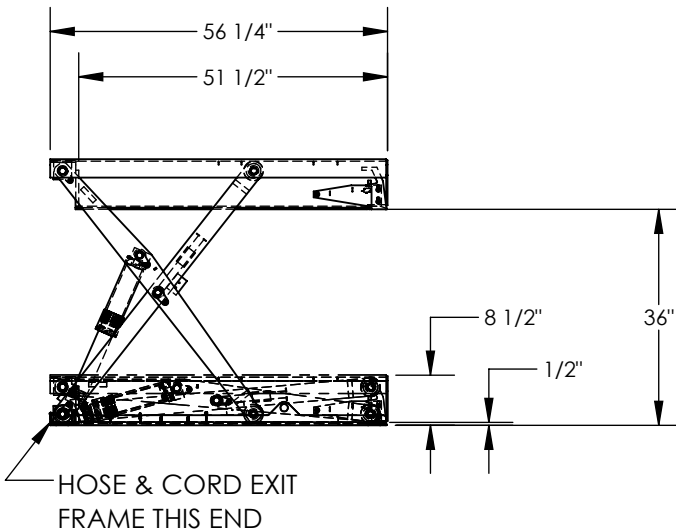

AVERAGE REACH
(W/O BENDING AT
WAIST)

6" HIGH
BACK PLATE

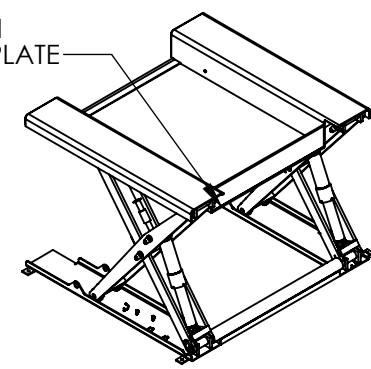

REMOTE POWER UNIT
32 1/2" x 12" 12 1/2" (L x W x H)
WITH 8' HOSE & CABLE

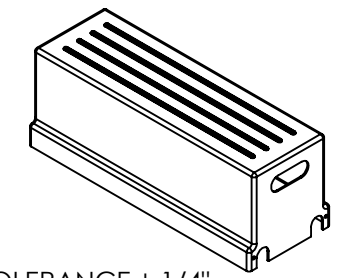

DIMENSION TOLERANCE ± 1/4"

STANDARD FEATURES

MODEL NUMBER IS: EHLTG-3850-2-36
 PLATFORM WIDTH (USABLE): 38"
 PLATFORM LENGTH (USABLE): 51 1/2"
 OVERALL WIDTH: 60 13/16"
 OVERALL LENGTH: 56 1/4"
 PLATFORM RAISED HEIGHT: 36"
 PLATFORM LOWERED HEIGHT: 1/2"
 EXTERNAL POWER UNIT
 CAPACITY: 2,000 LBS.
 DURABLE LIQUID PAINT BLUE FINISH
 CONTROL IS FOOT SWITCH, 2 PEDAL, NEMA 1
 WITH MINIMUM USABLE 8' STRAIGHT CORD

PLEASE CIRCLE SPECIFICATIONS:

POWER	<input checked="" type="checkbox"/> AC	<input type="checkbox"/> DC (12V)	<input type="checkbox"/> AIR/OIL
MOTOR VOLTAGE	<input type="checkbox"/> 115	<input type="checkbox"/> 208	<input checked="" type="checkbox"/> 230 460
DEDICATED CIRCUIT REQUIRED 60Hz			
MOTOR PHASE	<input type="checkbox"/> SINGLE	<input checked="" type="checkbox"/> THREE	
CONTROL	<input type="checkbox"/> HAND	<input checked="" type="checkbox"/> FOOT	

SPECIAL FEATURES
NONE

APPROVAL

I, THE UNDERSIGNED, AGREE THAT THE PRODUCT AS REPRESENTED SATISFIES DESIGN AND DIMENSION REQUIREMENTS. I ALSO ACKNOWLEDGE MY DUTY TO CONFIRM PRODUCT AND INSTALLATION COMPLIANCE WITH ALL APPLICABLE FEDERAL, STATE AND LOCAL REGULATIONS AND STANDARDS.

UNITS REQUIRING APPROVAL DRAWINGS OR MODIFIED ARE NON-RETURNABLE

[] As drawn [] As marked

Signed: _____ Date: _____

Printed Name: _____

LEAD TIME WILL START UPON RECEIPT OF SIGNED APPROVAL DRAWING

DISTRIBUTOR'S NAME:		P.O.#
VESTIL MANUFACTURING		X
DRAWN BY: JWW	DATE: 10/02/2013	W.O.#
REFERENCE: X	SCALE: 1:32	X
QUOTED LEAD TIME: X	QUOTE #	SALES: X
	X	FILE NAME:
		04-007-101