

# ELECTRIC HYDRAULIC SCISSOR LIFT TABLE - EHLT-4848-4-43-QS

APPROX WEIGHT: 758.77 lbs.  
DOES NOT INCLUDE WEIGHT OF POWER OR PACKAGING!!!

\*\*\* ANY ADDITIONS, DELETIONS, OR OMISSIONS MUST BE CORRECTED ON THIS DRAWING AS THIS DRAWING WILL BE CONSIDERED ALL INCLUSIVE \*\*\*  
ALL GRAPHICS PROVIDED ARE FOR REFERENCE ONLY. IF CERTAIN DIMENSIONS ARE CRITICAL PLEASE VERIFY THOSE DIMENSIONS WITH YOUR SALESPERSON

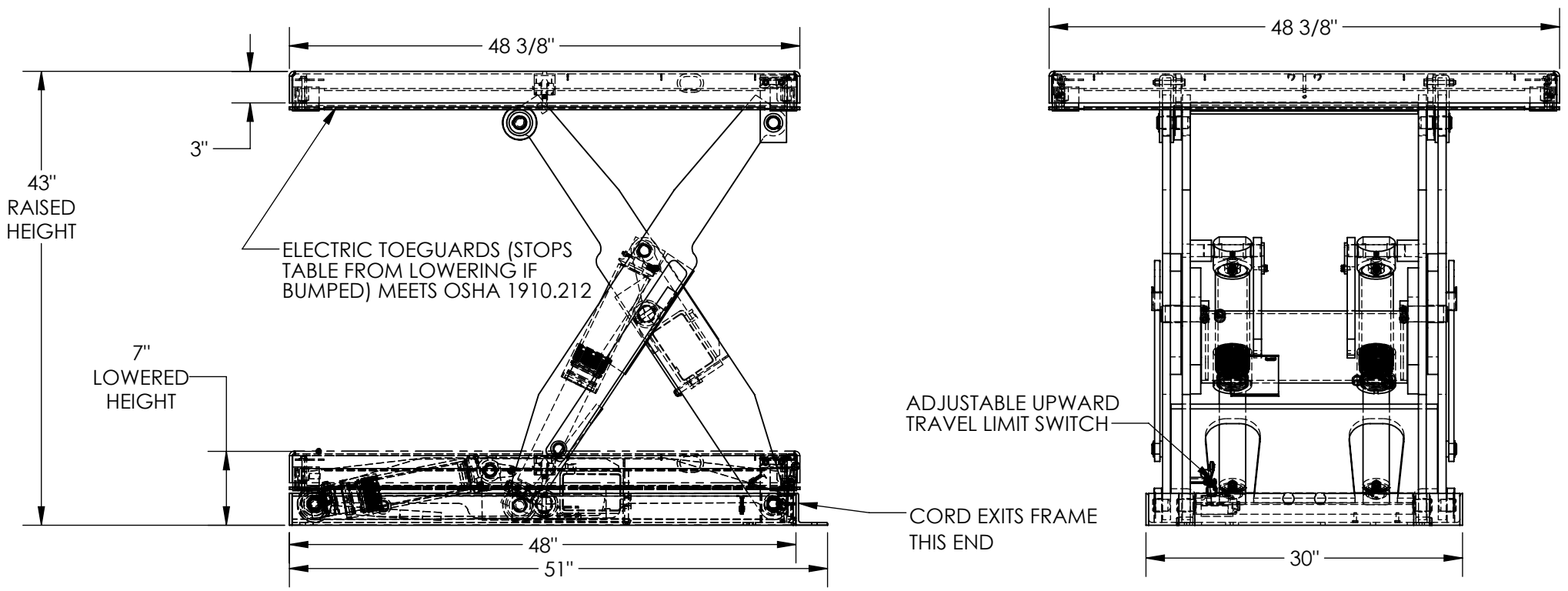

DECK TOLERANCE ± 1/2"  
TABLE HEIGHT TOLERANCE ± 1/2"  
DECK FLATNESS ± 1/4"

DIMENSION TOLERANCE ± 1/4"

## STANDARD FEATURES

- MODEL NUMBER IS EHLT-4848-4-43-QS
- PLATFORM WIDTH IS 48 3/8"
- PLATFORM LENGTH IS 48 3/8"
- OVERALL LENGTH IS 51"
- PLATFORM RAISED HEIGHT IS 43"
- PLATFORM LOWERED HEIGHT IS 7"
- TABLE CAPACITY (EVENLY DISTRIBUTED) LOAD IS 4,000 LBS
- CONTROL IS HANDHELD, 2 BUTTON, NEMA 4 PENDANT WITH MINIMUM 8' USABLE COIL CORD
- SAFETY MAINTENANCE PROPS, DISPLACEMENT STYLE CYLINDERS INSTALLED ROD DOWN
- EMERGENCY SAFETY STOP HYDRAULIC FUSES IN ALL CYLINDER UNITS HAVE 2' TEST LEAD AND PIG TAIL
- DURABLE LIQUID PAINT BLUE FINISH
- INTERNAL POWER UNIT

## SPECIAL FEATURES

NONE

## PLEASE CIRCLE SPECIFICATIONS:

POWER	AC	<del>DC (12V)</del>	<del>AIR/OIL</del>
MOTOR VOLTAGE	<del>115</del>	<del>208</del>	<del>230</del> 460
DEDICATED CIRCUIT REQUIRED 60Hz			
MOTOR PHASE	<del>SINGLE</del>	THREE	
CONTROL	HAND	<del>FOOT</del>	

**APPROVAL**

I, THE UNDERSIGNED, AGREE THAT THE PRODUCT AS REPRESENTED SATISFIES DESIGN AND DIMENSION REQUIREMENTS. I ALSO ACKNOWLEDGE MY DUTY TO CONFIRM PRODUCT AND INSTALLATION COMPLIANCE WITH ALL APPLICABLE FEDERAL, STATE AND LOCAL REGULATIONS AND STANDARDS.

**UNITS REQUIRING APPROVAL DRAWINGS OR MODIFIED ARE NON-RETURNABLE**

As drawn       As marked

Signed: \_\_\_\_\_ Date: \_\_\_\_\_

Printed Name: \_\_\_\_\_

*LEAD TIME WILL START UPON RECEIPT OF SIGNED APPROVAL DRAWING*

DISTRIBUTOR'S NAME:		P.O.#
VESTIL MANUFACTURING		X
DRAWN BY: BCN	DATE: 3/16/2019	W.O.#
REFERENCE: X	SCALE: 1:14	X
QUOTED LEAD TIME: X	QUOTE #	SALES: X
	X	FILE NAME:
		24-007-632