

ELECTRIC HYDRAULIC SCISSOR LIFT TABLE, PARTIAL STAINLESS STEEL - EHLT-4848-2-43-PSS

APPROX WEIGHT: 726.38 lbs.
DOES NOT INCLUDE WEIGHT OF POWER OR PACKAGING!!!

*** ANY ADDITIONS, DELETIONS, OR OMISSIONS MUST BE CORRECTED ON THIS DRAWING AS THIS DRAWING WILL BE CONSIDERED ALL INCLUSIVE ***
ALL GRAPHICS PROVIDED ARE FOR REFERENCE ONLY. IF CERTAIN DIMENSIONS ARE CRITICAL PLEASE VERIFY THOSE DIMENSIONS WITH YOUR SALESPERSON

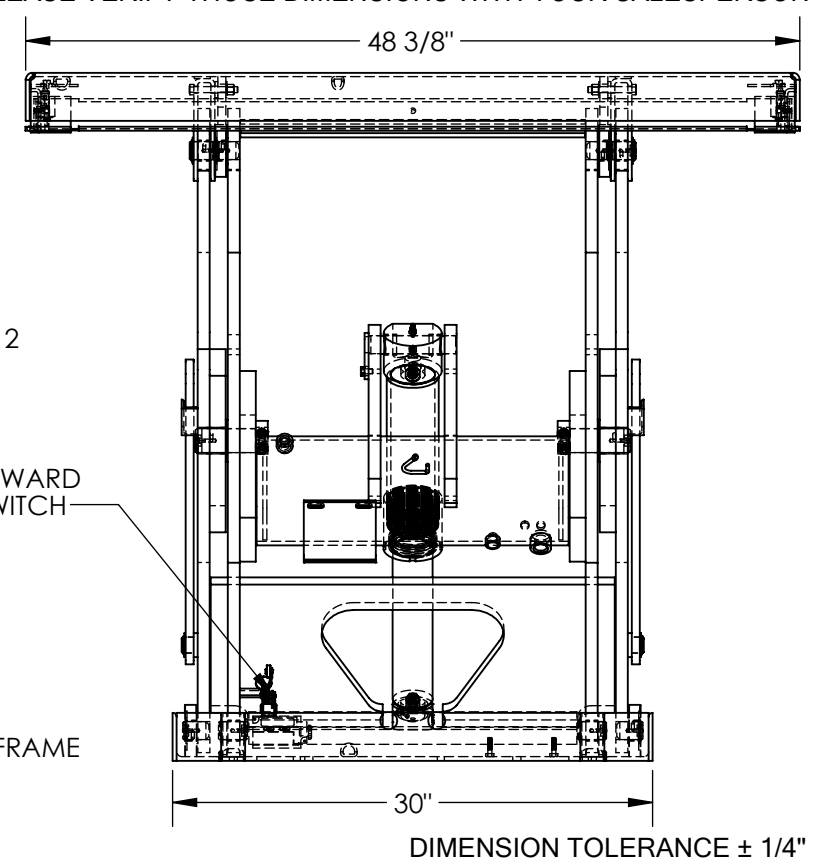
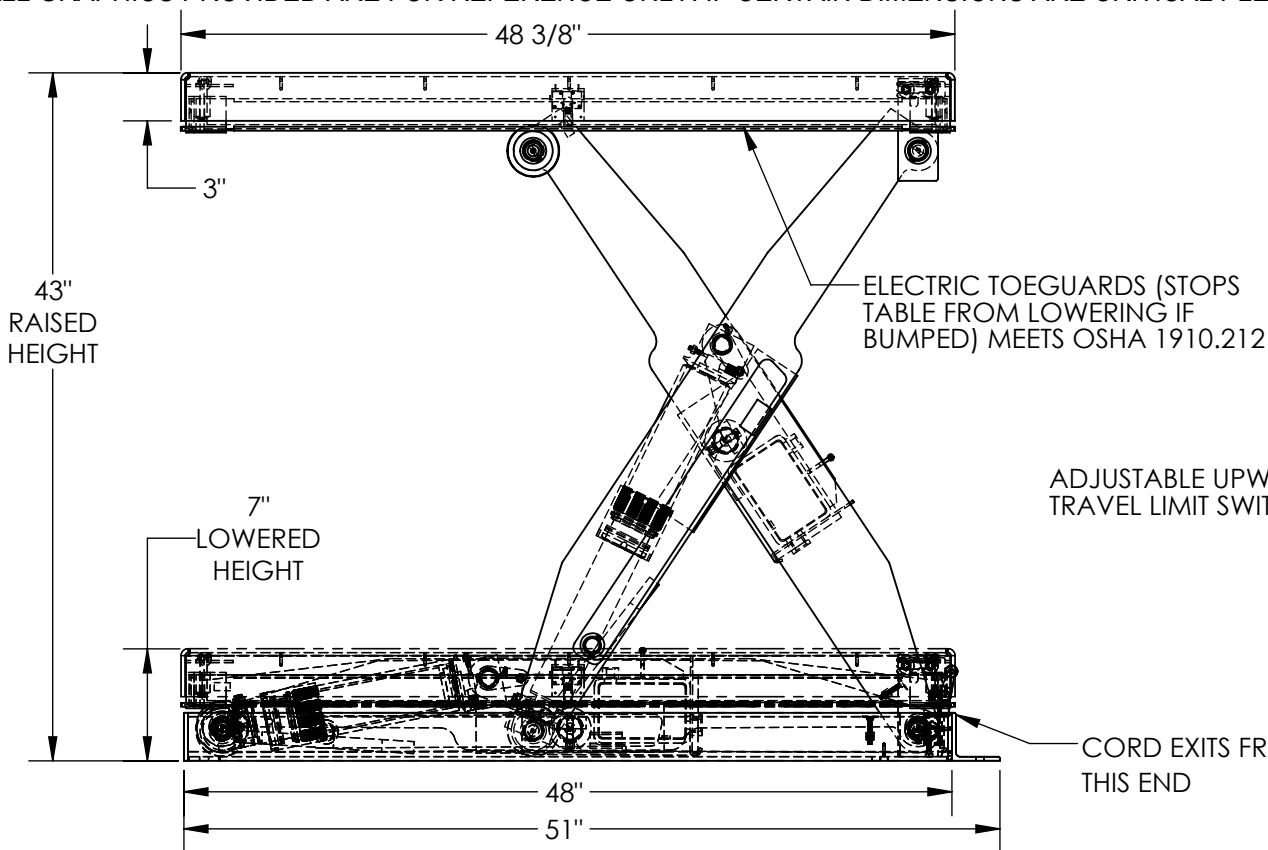

STANDARD FEATURES

MODEL NUMBER IS EHLT-4848-2-43-PSS
 PLATFORM WIDTH IS 48 3/8"
 PLATFORM LENGTH IS 48 3/8"
 OVERALL LENGTH IS 51"
 PLATFORM RAISED HEIGHT IS 43"
 PLATFORM LOWERED HEIGHT IS 7"
 TABLE CAPACITY (EVENLY DISTRIBUTED)
 LOAD IS 2,000 LBS
 INTERNAL POWER UNIT
 CONTROL IS HANDHELD, 2 BUTTON, NEMA 4
 PENDANT WITH MINIMUM 8' USABLE COIL CORD
 SAFETY MAINTENANCE PROPS, DISPLACEMENT
 STYLE CYLINDERS INSTALLED ROD DOWN
 EMERGENCY SAFETY STOP HYDRAULIC FUSES
 IN ALL CYLINDER. UNITS HAVE 2' TEST LEAD
 AND PIG TAIL
 FRAME AND DECK - MILL FINISH 304 STAINLESS STEEL
 GREASABLE PINS AND ROLLERS - 17-4 STAINLESS STEEL
 SCISSOR LEGSET - CARBON STEEL WITH
 TOUGH BAKED IN POWDER COATED WHITE FINISH
 STAINLESS STEEL COMPONENTS HAVE AN UNPOLISHED (MILL) FINISH

PLEASE CIRCLE SPECIFICATIONS:

POWER	AC	DC (12V)	AIR/OIL
MOTOR VOLTAGE	115	208	230 460
DEDICATED CIRCUIT REQUIRED 60Hz			
MOTOR PHASE	SINGLE	THREE	
CONTROL	HAND	FOOT	

DECK TOLERANCE ± 1/2"
 TABLE HEIGHT TOLERANCE ± 1/2"
 DECK FLATNESS ± 1/4"

APPROVAL

I, THE UNDERSIGNED, AGREE THAT THE PRODUCT AS REPRESENTED SATISFIES DESIGN AND DIMENSION REQUIREMENTS. I ALSO ACKNOWLEDGE MY DUTY TO CONFIRM PRODUCT AND INSTALLATION COMPLIANCE WITH ALL APPLICABLE FEDERAL, STATE AND LOCAL REGULATIONS AND STANDARDS.
UNITS REQUIRING APPROVAL DRAWINGS OR MODIFIED ARE NON-RETURNABLE
 As drawn As marked

Signed: _____ Date: _____

Printed Name: _____

LEAD TIME WILL START UPON RECEIPT OF SIGNED APPROVAL DRAWING

DISTRIBUTOR'S NAME:		P.O.#
VESTIL MANUFACTURING		X
DRAWN BY: BCN		W.O.#
DATE: 8/30/2017		X
REFERENCE: X	SCALE: 1:12	SALES: X
QUOTED LEAD TIME: X	QUOTE #	FILE NAME:
	X	24-007-045-001

SPECIAL FEATURES

NONE