

ELECTRIC HYDRAULIC DOCKLEVELER - EH-68-50

APPROX WEIGHT: 2344 lbs.
 DOES NOT INCLUDE WEIGHT OF POWER OR PACKAGING!!!

*** ANY ADDITIONS, DELETIONS, OR OMISSIONS MUST BE CORRECTED ON THIS DRAWING AS THIS DRAWING WILL BE CONSIDERED ALL INCLUSIVE ***
 ALL GRAPHICS PROVIDED ARE FOR REFERENCE ONLY. IF CERTAIN DIMENSIONS ARE CRITICAL PLEASE VERIFY THOSE DIMENSIONS WITH YOUR SALESPERSON

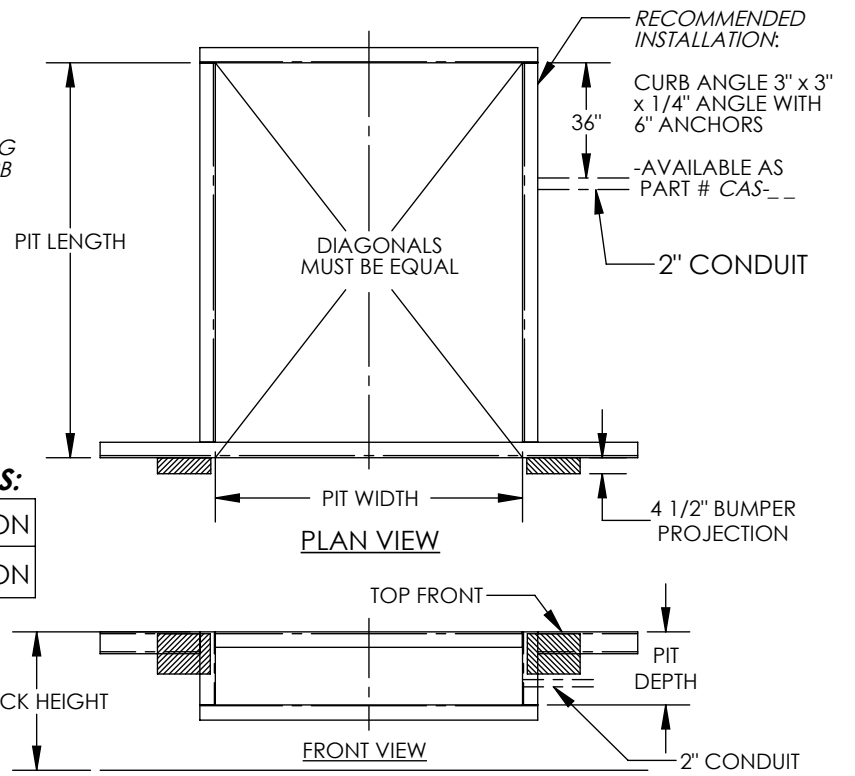
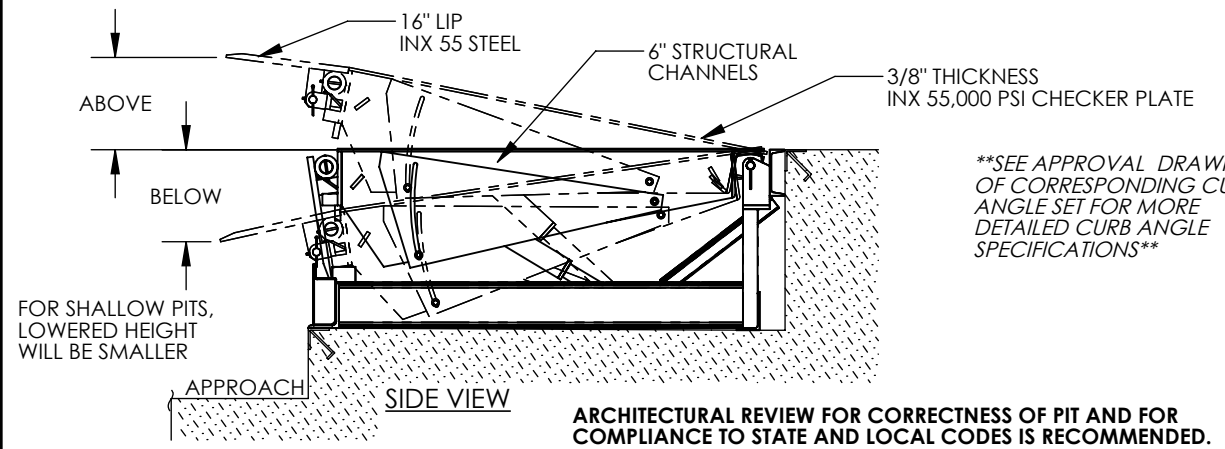

STANDARD FEATURES

- DOCKLEVELER MODEL NUMBER: EH-68-50
- PIT WIDTH IS 74 INCHES
- PIT LENGTH IS 86 INCHES
- PIT DEPTH IS 24 INCHES AT FRONT, 23 3/4 INCHES AT BACK
- DOCK HEIGHT IS 48 INCHES (48 INCHES STANDARD)
- DOCKLEVELER CAPACITY (GROSS ROLLING LOAD) IS 50,000 LBS.
- VERTICAL SERVICE RANGE IS 12 INCHES ABOVE AND 12 INCHES BELOW DOCK
- INCLUDES (2) 1014-4.5 LAMINATED DOCK BUMPERS
- DURABLE LIQUID PAINT BROWN FINISH WITH YELLOW DECK SIDES & TOE GUARDS
- ***SINGLE AXLE CAPACITY NOT TO EXCEED 70% OF LOAD***

PLEASE CIRCLE SPECIFICATIONS:

NEW	(PIT) CONSTRUCTION
EXISTING	(PIT) CONSTRUCTION

ALL STRUCTURAL STEEL CONSTRUCTION WELDING MEETS AWS. DESIGN, ENGINEERING, AND FABRICATION COMPLIES WITH OSHA & ANSI MH30.1

- REFER TO THE UNIT'S ELECTRICAL DIAGRAM FOR ELECTRICAL SERVICE REQUIREMENTS.
- INSTALL TO MEET ALL APPLICABLE STATE & LOCAL CODES FOR YOUR AREA!
- NOTE: ONE 18/2 STD AND 14/3 (FOR 1 PHASE) OR 14/4 (FOR 3 PHASE) STD CABLE (OR EQUIVALENT) MUST BE PROVIDED BY THE INSTALLER IN ORDER TO COMPLETE THE INSTALLATION.

SPECIAL FEATURES

NONE

FOR INTERNAL USE ONLY
 PROJECT SIGN OFF

SALES	
ENG.	
FAB.	
POWER	

PLEASE CIRCLE SPECIFICATIONS:

POWER	<input checked="" type="checkbox"/> AC	<input type="checkbox"/> * DC	<input type="checkbox"/> * AIR/OIL	
MOTOR VOLTAGE	<input type="checkbox"/> 115	<input type="checkbox"/> 208	<input checked="" type="checkbox"/> 230	<input type="checkbox"/> 460
DEDICATED CIRCUIT REQUIRED				
MOTOR PHASE	<input type="checkbox"/> SINGLE	<input checked="" type="checkbox"/> THREE		
CONTROL	<input checked="" type="checkbox"/> HAND	<input type="checkbox"/> * FOOT		
~ ALL BATTERY CHARGERS ARE 115V AC ~				
* BATTERY CHRG.	<input type="checkbox"/> REMOTE	<input checked="" type="checkbox"/> ON-BOARD		
* CHRG. INDICATOR	<input checked="" type="checkbox"/> YES	<input type="checkbox"/> NO		

* AVAILABLE AT ADDITIONAL COST

SEE DRAWING NUMBERS EH-1 THRU EH-4 FOR MORE INSTALLATION INFO

DIMENSION TOLERANCE ± 1/4"

A P P R O V A L

I, THE UNDERSIGNED, AGREE THAT THE PRODUCT AS REPRESENTED SATISFIES DESIGN AND DIMENSION REQUIREMENTS. I ALSO ACKNOWLEDGE MY DUTY TO CONFIRM PRODUCT AND INSTALLATION COMPLIANCE WITH ALL APPLICABLE FEDERAL, STATE AND LOCAL REGULATIONS AND STANDARDS.

ANY MODIFIED UNITS ARE NON-RETURNABLE

[] As drawn [] As marked

Signed: _____ Date: _____

Printed Name: _____

LEAD TIME WILL START UPON RECEIPT OF SIGNED APPROVAL DRAWING

DISTRIBUTOR'S NAME:		P.O.#
VESTIL MANUFACTURING		X
DRAWN BY: TJM		W.O.#
DATE: 05/18/11		X
SALES: X	SCALE: NTS	FILE NAME:
REFERENCE: X		06-007-034
QUOTED LEAD TIME: X	QUOTE #	
	X	