

MANUAL DRUM LIFTER/ROTATOR - DRUM-LRT

ANY ADDITIONS, DELETIONS, OR OMISSIONS MUST BE CORRECTED ON THIS DRAWING AS THIS DRAWING WILL BE CONSIDERED ALL INCLUSIVE

STANDARD FEATURES

MODEL # DRUM-LRT
 CAPACITY: 550 LBS.
 LIFT HEIGHT: 62"
 MAST: SINGLE
 SAFETY SHIELD: YES
 OVERALL MAST HEIGHT: 85 7/16"
 STEERING WHEEL: Ø7 X 2"
 FRONT WHEEL: Ø7X2"
 HYDRAULIC HAND PUMP
 NUMBER OF PUMPS TO RAISE THE DRUM TO MAXIMUM HEIGHT: 71 PUMPS
 NUMBER OF TURNS TO ROTATE THE DRUM 360°: 42
 DOWN TIME: 24.28 SECS.
 GEAR RATIO: 1:42
 TOUGH BAKED IN POWDER COATED BLACK & YELLOW FINISH

ALL GRAPHICS PROVIDED ARE FOR REFERENCE ONLY. IF CERTAIN DIMENSIONS ARE CRITICAL PLEASE VERIFY THOSE DIMENSIONS WITH YOUR SALESPERSON

SPECIAL FEATURES

NONE

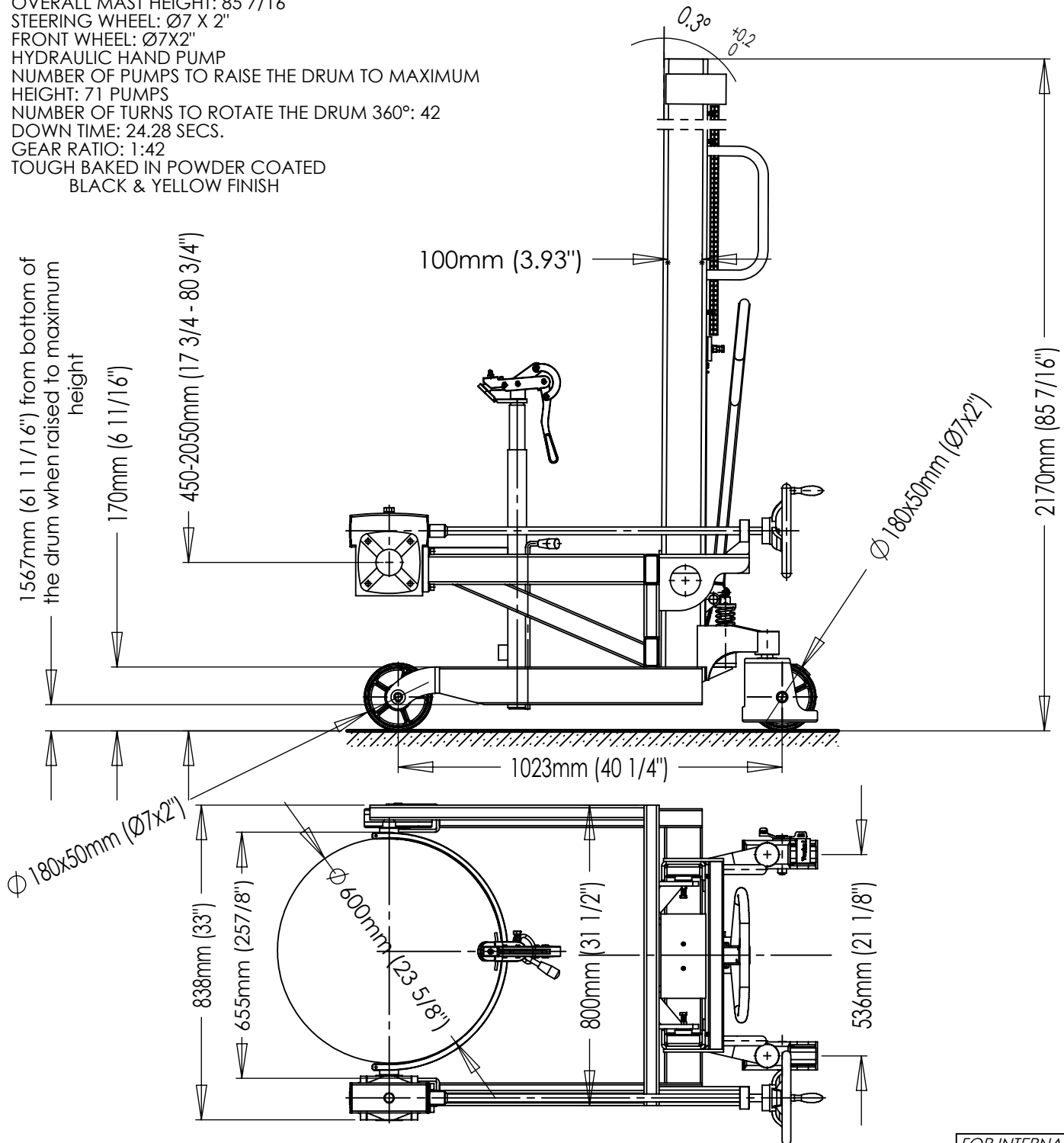

FOR INTERNAL USE ONLY
 PROJECT SIGN OFF

SALES	
ENG.	
FAB.	
POWER	

APPROVAL

I, THE UNDERSIGNED, AGREE THAT THE PRODUCT AS REPRESENTED SATISFIES DESIGN AND DIMENSION REQUIREMENTS. I ALSO ACKNOWLEDGE MY DUTY TO CONFIRM PRODUCT AND INSTALLATION COMPLIANCE WITH ALL APPLICABLE FEDERAL, STATE AND LOCAL REGULATIONS AND STANDARDS.

UNITS REQUIRING APPROVAL DRAWINGS OR MODIFIED ARE NON-RETURNABLE

[] As drawn [] As marked

Signed: _____ Date: _____

Printed Name: _____

LEAD TIME WILL START UPON RECEIPT OF SIGNED APPROVAL DRAWING

DISTRIBUTOR'S NAME:		P.O.#	X
VESTIL MANUFACTURING		W.O.#	X
DRAWN BY:	SJG	DATE:	7/31/2018
REFERENCE:	X	SCALE:	NTS
QUOTED LEAD TIME:	X	QUOTE #	X
			SALES:
			X
			FILE NAME:
			DRUM-LRT