

ERGO-HANDLE CART - DH-PH4-3460

APPROX WEIGHT: 257.96 lbs.
 DOES NOT INCLUDE WEIGHT OF POWER OR PACKAGING!!!

*** ANY ADDITIONS, DELETIONS, OR OMISSIONS MUST BE CORRECTED ON THIS DRAWING AS THIS DRAWING WILL BE CONSIDERED ALL INCLUSIVE ***

ALL GRAPHICS PROVIDED ARE FOR REFERENCE ONLY. IF CERTAIN DIMENSIONS ARE CRITICAL PLEASE VERIFY THOSE DIMENSIONS WITH YOUR SALESPERSON

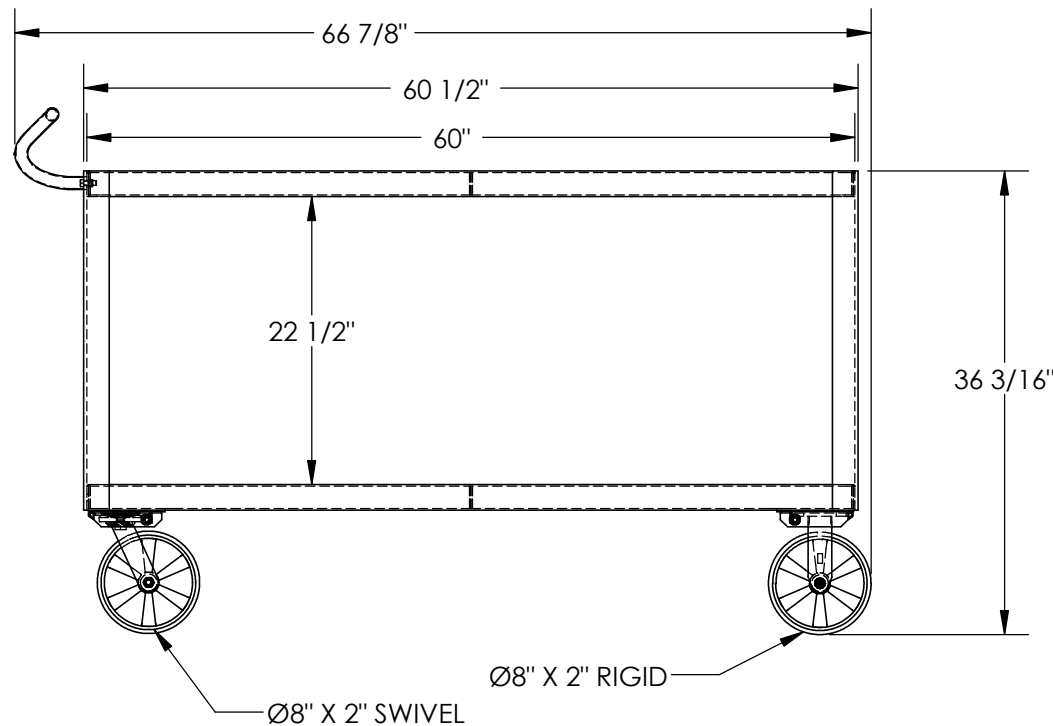
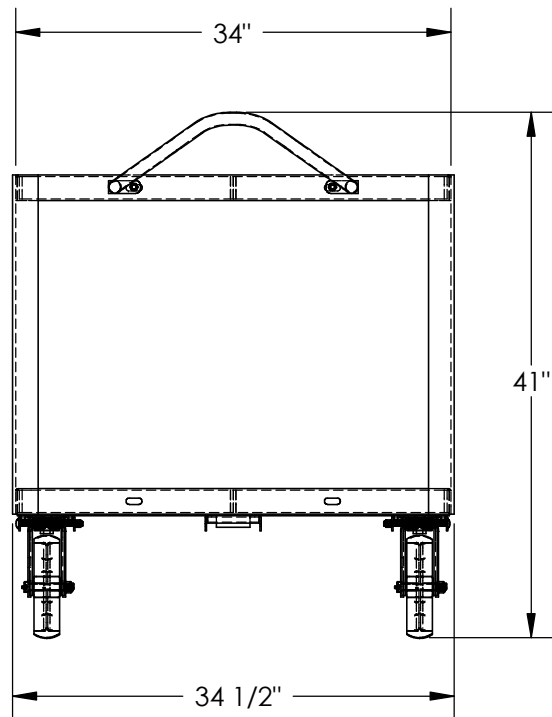

FOR INTERNAL USE ONLY PROJECT SIGN OFF	
SALES	
ENG.	
FAB.	
POWER	

STANDARD FEATURES

- MODEL NUMBER IS DH-PH4-3460
- MAXIMUM CART CAPACITY IS 4,000 LBS.
- MAXIMUM SHELF CAPACITY IS 2,000 LBS.
- NOT TO EXCEED MAXIMUM CAPACITY OF THE CART
- OVERALL WIDTH IS: 34 1/2"
- USABLE WIDTH IS: 34"
- OVERALL LENGTH IS: 66 7/8"
- USABLE LENGTH IS: 60"
- OVERALL HEIGHT IS: 41"
- SHELF CLEARANCE IS: 22 1/2"
- 2 RIGID 8" x 2" GLASS FILLED NYLON CASTERS
- 2 SWIVEL 8" x 2" GLASS FILLED NYLON CASTERS
- STEEL CONSTRUCTION

SPECIAL FEATURES

NONE

DIMENSION TOLERANCE ± 1/4"

APPROVAL	I, THE UNDERSIGNED, AGREE THAT THE PRODUCT AS REPRESENTED SATISFIES DESIGN AND DIMENSION REQUIREMENTS. I ALSO ACKNOWLEDGE MY DUTY TO CONFIRM PRODUCT AND INSTALLATION COMPLIANCE WITH ALL APPLICABLE FEDERAL, STATE AND LOCAL REGULATIONS AND STANDARDS.	
	ANY MODIFIED UNITS ARE NON-RETURNABLE	
	[] As drawn [] As marked	
	Signed: _____	Date: _____
Printed Name: _____		
LEAD TIME WILL START UPON RECEIPT OF SIGNED APPROVAL DRAWING		

DISTRIBUTOR'S NAME:		P.O.#
VESTIL MANUFACTURING		X
DRAWN BY: T.MOORE		W.O.#
DATE: 08/20/10		X
REFERENCE: X	SCALE: 1:15	SALES: X
QUOTED LEAD TIME: X	QUOTE #	FILE NAME:
	X	16-007-068