

# ERGO-HANDLE CART - DH-PH4-3060

APPROX WEIGHT: 238.57 lbs.  
 DOES NOT INCLUDE WEIGHT OF POWER OR PACKAGING!!!

\*\*\* ANY ADDITIONS, DELETIONS, OR OMISSIONS MUST BE CORRECTED ON THIS DRAWING AS THIS DRAWING WILL BE CONSIDERED ALL INCLUSIVE \*\*\*

ALL GRAPHICS PROVIDED ARE FOR REFERENCE ONLY. IF CERTAIN DIMENSIONS ARE CRITICAL PLEASE VERIFY THOSE DIMENSIONS WITH YOUR SALESPERSON

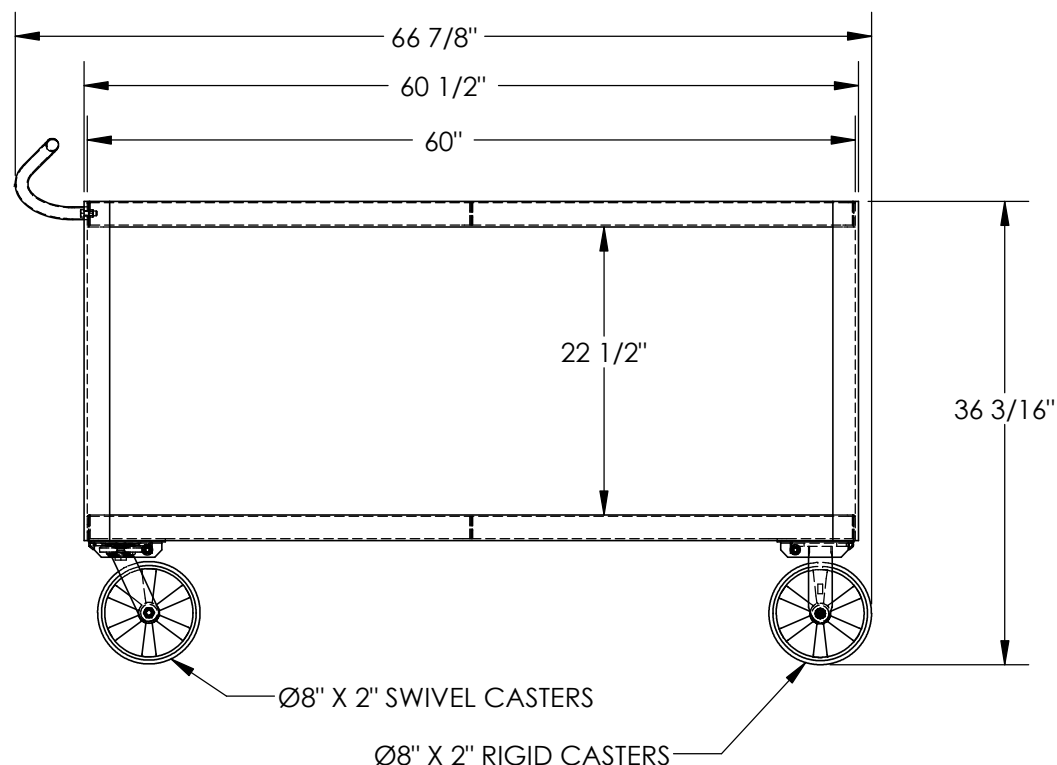
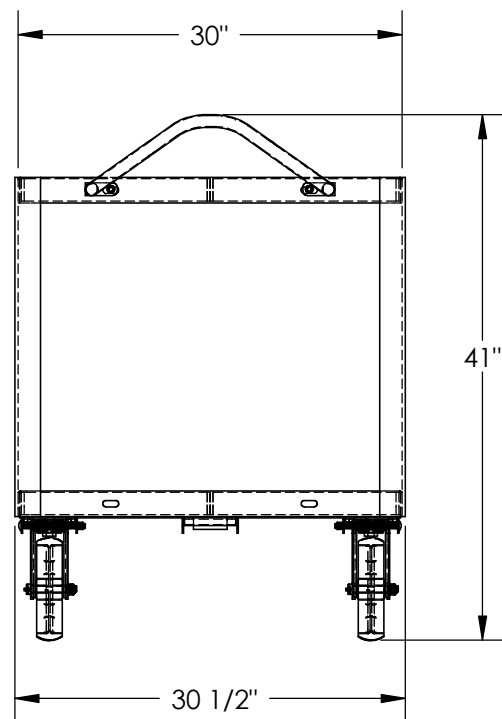

## STANDARD FEATURES

- MODEL NUMBER IS DH-PH4-3060
- MAXIMUM CART CAPACITY IS 4,000 LBS.
- MAXIMUM SHELF CAPACITY IS 2,000 LBS.
- NOT TO EXCEED MAXIMUM CAPACITY OF THE CART
- OVERALL WIDTH IS: 30 1/2"
- USABLE WIDTH IS: 30"
- OVERALL LENGTH IS: 66 7/8"
- USABLE LENGTH IS: 60"
- OVERALL HEIGHT IS: 41"
- SHELF CLEARANCE IS: 22 1/2"
- 2 RIGID 8" x 2" GLASS FILLED NYLON CASTERS
- 2 SWIVEL 8" x 2" GLASS FILLED NYLON CASTERS
- STEEL CONSTRUCTION

## STANDARD FEATURES

NONE

DIMENSION TOLERANCE ± 1/4"

FOR INTERNAL USE ONLY PROJECT SIGN OFF	
SALES	
ENG.	
FAB.	
POWER	

**APPROVAL**

I, THE UNDERSIGNED, AGREE THAT THE PRODUCT AS REPRESENTED SATISFIES DESIGN AND DIMENSION REQUIREMENTS. I ALSO ACKNOWLEDGE MY DUTY TO CONFIRM PRODUCT AND INSTALLATION COMPLIANCE WITH ALL APPLICABLE FEDERAL, STATE AND LOCAL REGULATIONS AND STANDARDS.

**ANY MODIFIED UNITS ARE NON-RETURNABLE**

[ ] As drawn [ ] As marked

Signed: \_\_\_\_\_ Date: \_\_\_\_\_

Printed Name: \_\_\_\_\_

LEAD TIME WILL START UPON RECEIPT OF SIGNED APPROVAL DRAWING

DISTRIBUTOR'S NAME:		P.O.#
VESTIL MANUFACTURING		X
DRAWN BY: T.MOORE		DATE: 08/20/2010
REFERENCE: X		SCALE: 1:15
QUOTED LEAD TIME: X		QUOTE # X
		FILE NAME: 16-007-070
		SALES: X
		W.O.#
		X