

ERGO-HANDLE CART - DH-PH4-3060-3

APPROX WEIGHT: 318.16 lbs.
DOES NOT INCLUDE WEIGHT OF POWER OR PACKAGING!!!

*** ANY ADDITIONS, DELETIONS, OR OMISSIONS MUST BE CORRECTED ON THIS DRAWING AS THIS DRAWING WILL BE CONSIDERED ALL INCLUSIVE ***

ALL GRAPHICS PROVIDED ARE FOR REFERENCE ONLY. IF CERTAIN DIMENSIONS ARE CRITICAL PLEASE VERIFY THOSE DIMENSIONS WITH YOUR SALESPERSON

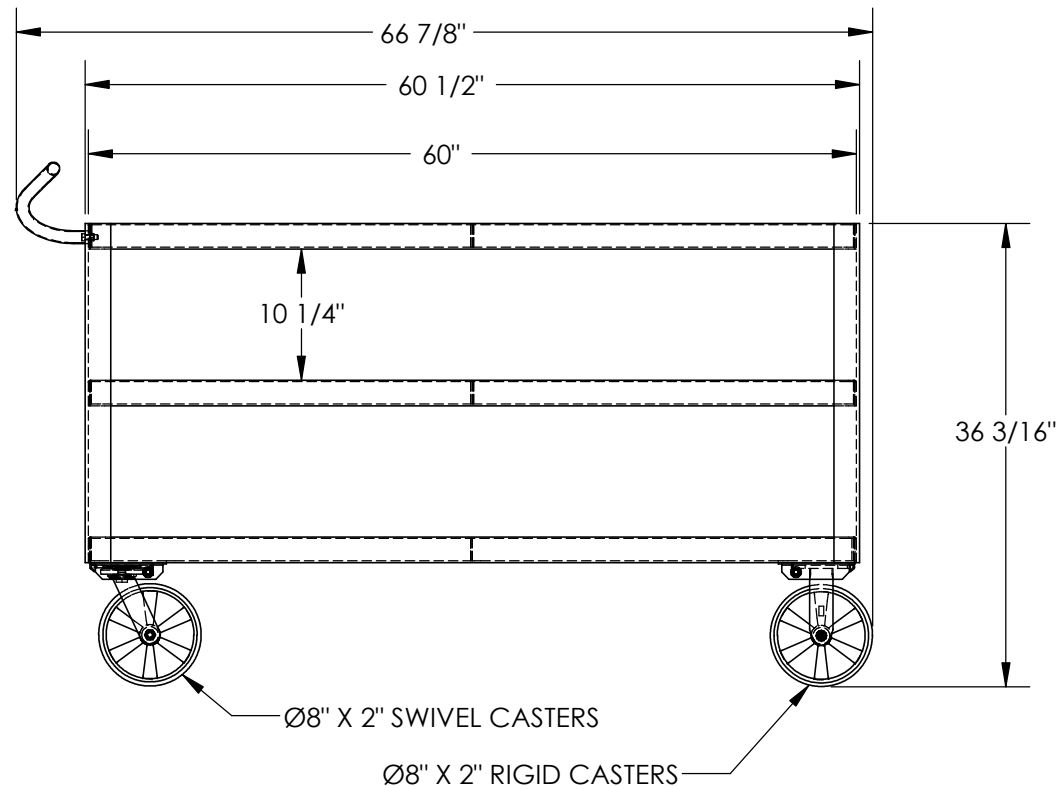
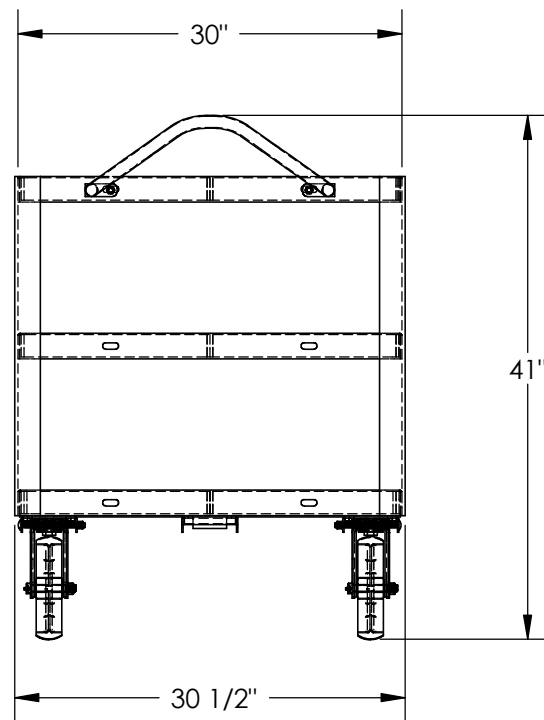

STANDARD FEATURES

- MODEL NUMBER IS DH-PH4-3060-3
- MAXIMUM CART CAPACITY IS 4,000 LBS.
- MAXIMUM SHELF CAPACITY IS 2,000 LBS.
- NOT TO EXCEED MAXIMUM CAPACITY OF THE CART
- OVERALL WIDTH IS: 30 1/2"
- USABLE WIDTH IS: 30"
- OVERALL LENGTH IS: 66 7/8"
- USABLE LENGTH IS: 60"
- OVERALL HEIGHT IS: 41"
- SHELF CLEARANCE IS: 10 1/4"
- 2 RIGID 8" x 2" GLASS FILLED NYLON CASTERS
- 2 SWIVEL 8" x 2" GLASS FILLED NYLON CASTERS
- STEEL CONSTRUCTION

SPECIAL FEATURES

NONE

DIMENSION TOLERANCE ± 1/4"

APPROVAL	I, THE UNDERSIGNED, AGREE THAT THE PRODUCT AS REPRESENTED SATISFIES DESIGN AND DIMENSION REQUIREMENTS. I ALSO ACKNOWLEDGE MY DUTY TO CONFIRM PRODUCT AND INSTALLATION COMPLIANCE WITH ALL APPLICABLE FEDERAL, STATE AND LOCAL REGULATIONS AND STANDARDS.	
	ANY MODIFIED UNITS ARE NON-RETURNABLE	
	[] As drawn [] As marked	
	Signed: _____	Date: _____
Printed Name: _____		
LEAD TIME WILL START UPON RECEIPT OF SIGNED APPROVAL DRAWING		

FOR INTERNAL USE ONLY PROJECT SIGN OFF	
SALES	
ENG.	
FAB.	
POWER	

DISTRIBUTOR'S NAME:		P.O.#
VESTIL MANUFACTURING		X
DRAWN BY: T.MOORE		W.O.#
DATE: 08/20/2010		X
REFERENCE: X	SCALE: 1:15	SALES: X
QUOTED LEAD TIME: X	QUOTE #	FILE NAME:
	X	33-007-085