

ERGO-HANDLE CART - DH-PH4-2472

APPROX WEIGHT: 234.85 lbs.
DOES NOT INCLUDE WEIGHT OF POWER OR PACKAGING!!!

*** ANY ADDITIONS, DELETIONS, OR OMISSIONS MUST BE CORRECTED ON THIS DRAWING AS THIS DRAWING WILL BE CONSIDERED ALL INCLUSIVE ***

ALL GRAPHICS PROVIDED ARE FOR REFERENCE ONLY. IF CERTAIN DIMENSIONS ARE CRITICAL PLEASE VERIFY THOSE DIMENSIONS WITH YOUR SALESPERSON

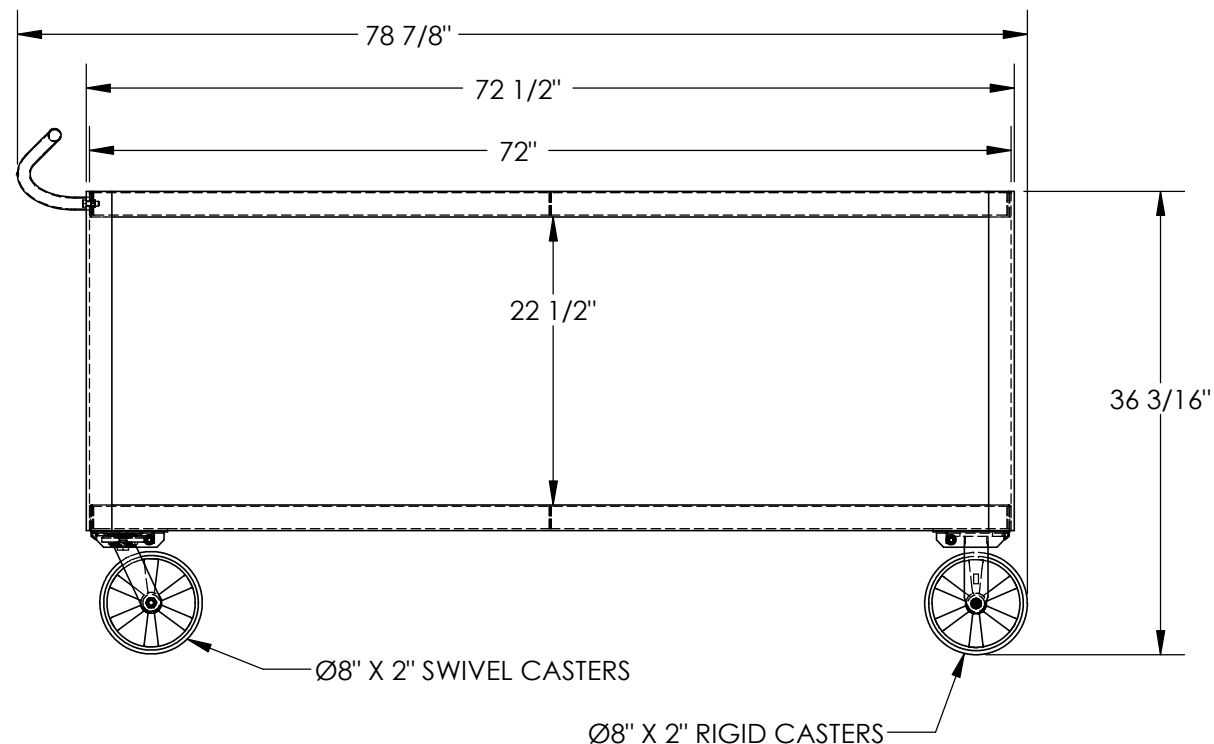
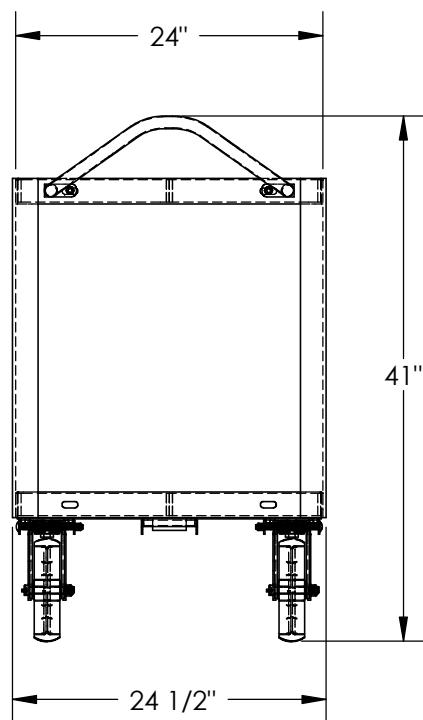

STANDARD FEATURES

- MODEL NUMBER IS DH-PH4-2472
- MAXIMUM CART CAPACITY IS 4,000 LBS.
- MAXIMUM SHELF CAPACITY IS 2,000 LBS.
- NOT TO EXCEED MAXIMUM CAPACITY OF THE CART
- OVERALL WIDTH IS: 24 1/2"
- USABLE WIDTH IS: 24"
- OVERALL LENGTH IS: 78 7/8"
- USABLE LENGTH IS: 72"
- OVERALL HEIGHT IS: 41"
- SHELF CLEARANCE IS: 22 1/2"
- 2 RIGID 8" x 2" GLASS FILLED NYLON CASTERS
- 2 SWIVEL 8" x 2" GLASS FILLED NYLON CASTERS
- STEEL CONSTRUCTION

SPECIAL FEATURES

NONE

FOR INTERNAL USE ONLY PROJECT SIGN OFF	
SALES	
ENG.	
FAB.	
POWER	

DIMENSION TOLERANCE ± 1/4"

APPROVAL

I, THE UNDERSIGNED, AGREE THAT THE PRODUCT AS REPRESENTED SATISFIES DESIGN AND DIMENSION REQUIREMENTS. I ALSO ACKNOWLEDGE MY DUTY TO CONFIRM PRODUCT AND INSTALLATION COMPLIANCE WITH ALL APPLICABLE FEDERAL, STATE AND LOCAL REGULATIONS AND STANDARDS.

ANY MODIFIED UNITS ARE NON-RETURNABLE

[] As drawn [] As marked

Signed: _____ Date: _____

Printed Name: _____

LEAD TIME WILL START UPON RECEIPT OF SIGNED APPROVAL DRAWING

DISTRIBUTOR'S NAME:		P.O.#
VESTIL MANUFACTURING		X
DRAWN BY: T.MOORE		DATE: 08/20/2010
REFERENCE: X		SCALE: 1:15
QUOTED LEAD TIME: X		QUOTE # X
		FILE NAME: 16-007-066