

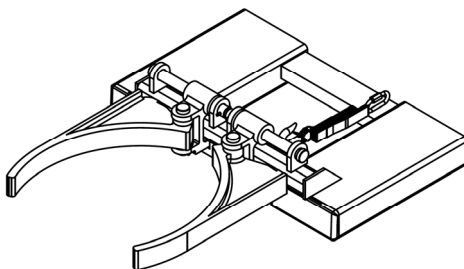

Vestil Manufacturing Corp.
 2999 North Wayne Street, P.O. Box 507, Angola, IN 46703
 Telephone: (260) 665-7586 -or- Toll Free (800) 348-0868
 Fax: (260) 665-1339
www.vestilmfg.com Email: info@vestil.com

DGS-A, DGD-A, & DGS-AG Fork-Mounted Drum Lifters Use and Maintenance Manual



DGS-A

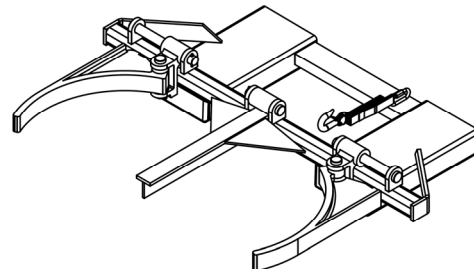

DGD-A

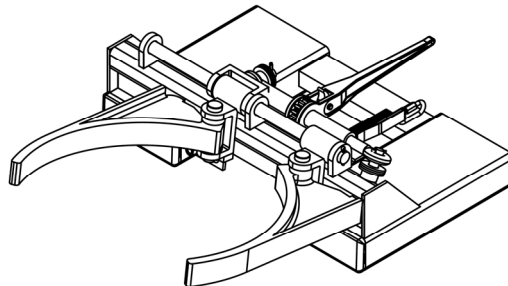

DGS-AG

Receiving instructions:

After delivery, remove the packaging from the product. Inspect the product closely to determine whether it sustained damage during transport. If damage is discovered, record a complete description of it on the bill of lading. If the product is undamaged, discard the packaging.

NOTE:

The end-user is solely responsible for confirming that product design, installation, use, and maintenance comply with laws, regulations, codes, and mandatory standards applied where the product is used.

Table of Contents

Signal Words.....	2
Hazards of Improper Use.....	2
DGS-A Parts Diagram, Bill of Materials, and Specifications.....	3
DGS-AG Parts Diagram, Bill of Materials, and Specifications.....	4
DGD-A Parts Diagram, Bill of Materials, and Specifications.....	5
Using the Drum Carrier.....	6
Inspections & Maintenance.....	7
Labeling Diagram.....	7
Limited Warranty.....	8

Signal Words:

This manual uses SIGNAL WORDS to direct the reader's attention to statements about uses of the product that could result in personal injury or property damage. Each signal word correlates with a specific hazard level.



Identifies a hazardous situation which, if not avoided, **WILL** result in **DEATH** or **SERIOUS INJURY**. Use of this signal word is limited to the most extreme situations.



Identifies a hazardous situation which, if not avoided, **COULD** result in **DEATH** or **SERIOUS INJURY**.



Identifies practices likely to result in product/property damage, such as operation that might damage the drum lifter.

Hazards of Improper Use:

Vestil strives to identify all hazards that could arise while using its products. However, material handling is dangerous. No manual can address every conceivable risk. Ultimately, the most effective way to avoid injury is to apply sound judgment whenever using this device.



Improper or careless use of this product might result in serious personal injury.

- DO NOT exceed the maximum rated load of your lifter (see Label 287 on product; "Labeling diagram" on p. 7; "Specifications" on pp. 3-5).
- Inspect the lifter before each use—before mounting it to your fork lift. DO NOT use this drum lifter unless it is in normal condition! "Normal condition" is defined in "Inspections & Maintenance" on p. 7. DO NOT use the drum lifter until it is restore to normal condition.
- Inspect the drum before using the carrier to transport it. Make sure that the drum (particularly the rim and rolling hoops) is in good condition. DO NOT attempt to lift or transport a damaged drum with the carrier.
- Stay clear of the drum and carrier! No part of your body should ever be beneath any part of the lifter or drum.
- ONLY use this device to move the type of drum(s) that is/are compatible with your carrier model (steel, plastic, and fiber). Compatibility is indicated in the "Specifications" information on pages 3-5.
- When transporting a drum, only raise it a few inches above the ground.
- Transport drums slowly. Avoid rough terrain when transporting drums. Jostling might disrupt the grasp on the rim.
- Avoid sudden stops when transporting drums. Brake gradually. Sudden stops could cause the carrier to slide on the forks and could damage the safety strap, hook, and/or quick link. Turn slowly. Sharp, quick turns could disrupt the clamp on the drum and damage the carrier.
- DO NOT modify the product in any way without first obtaining written approval from Vestil. Unapproved modifications automatically void the Limited Warranty (p. 8) and might make the carrier unsafe to use.
- DO NOT use the lifter UNLESS all labels (see "Labeling diagram" on p. 7) are in place, readable, and undamaged.
- The safety strap must be used every time the unit is mounted on a fork truck. Wrap the free end of the strap around the fork carriage; then fasten the hook to the strap or carriage **without slack (strap must be taut)**.

DGS-A parts diagram and bill of materials

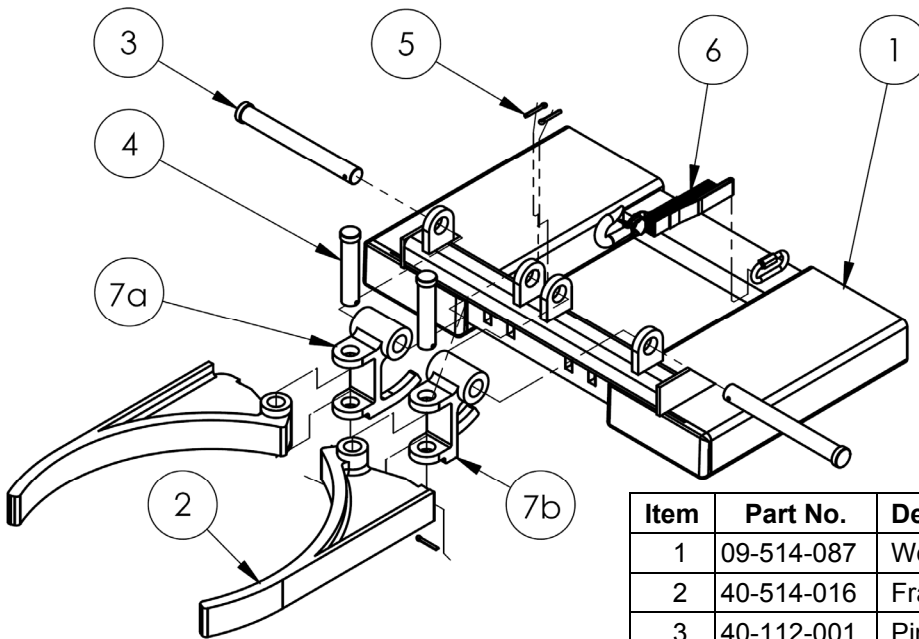

Item	Part No.	Description	Qty.
1	09-514-087	Weldment, frame	1
2	40-514-016	Frame, casting, arm	2
3	40-112-001	Pin, main, clevis	2
4	15-112-014	Pin, clevis, 1" x 4 1/2"	2
5	65125	Cotter pin, zinc plated, 3/16" x 1 1/2"	4
6	08-145-028	Restraining/safety strap	1
7a	40-012-010	Hinge, casting, arm, right	1
7b	40-012-011	Hinge, casting, arm, left	1

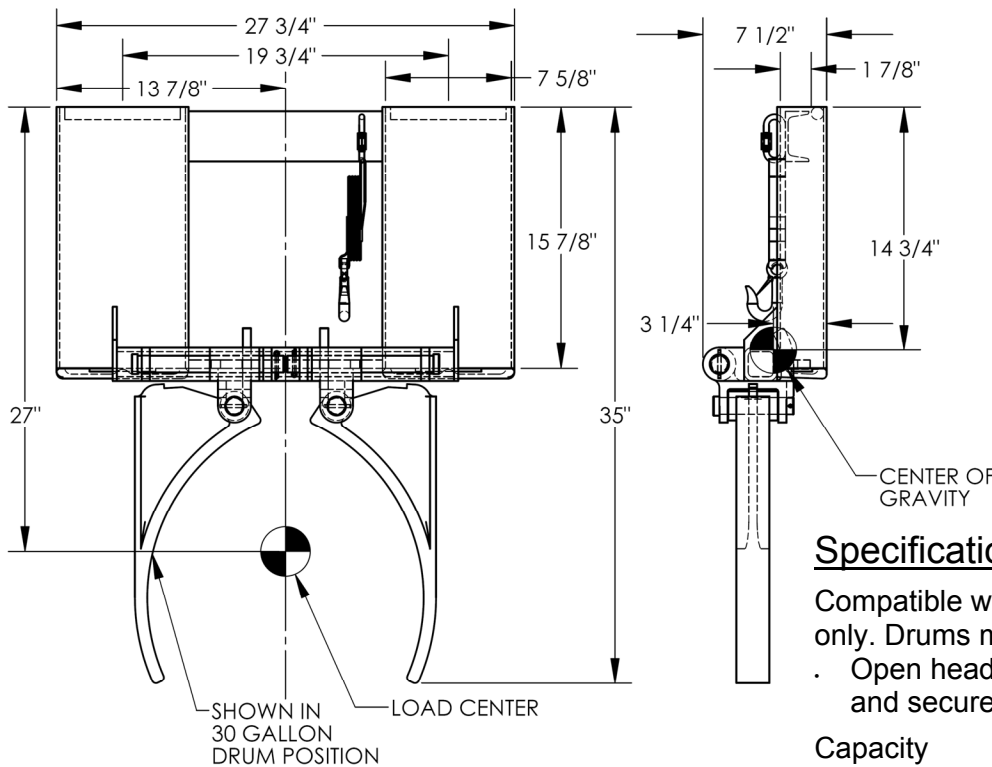

Specifications:

Compatible with 30gal. and 50gal. steel drums only. Drums may be open or closed head.

- Open head drums must have lids properly and securely fastened.

Capacity = 800 lb. (363.6 kg)

Net weight = 109 lb. (49.4 kg)

Arms pivot about a horizontal axis to fold onto the frame for storage.

Distance between fork tube centers = 19 3/4"

Usable fork tube dimensions = 7 5/8" W x 1 7/8" H

DGS-AG parts diagram & bill of materials

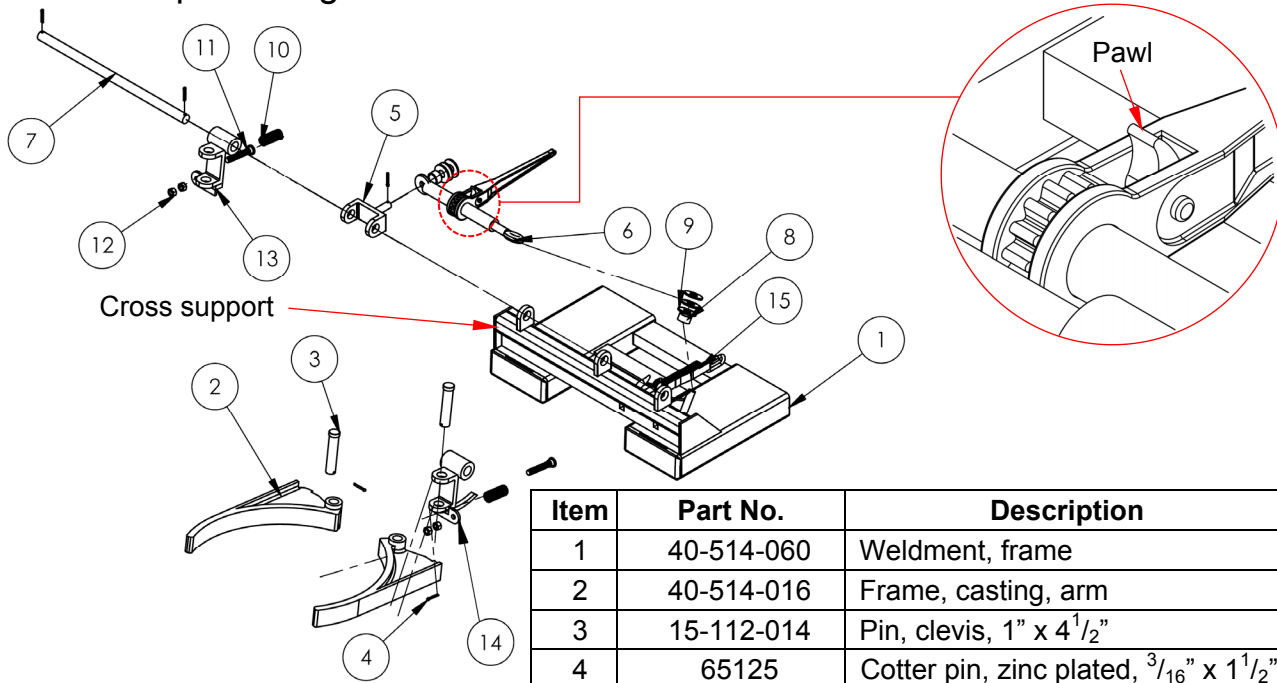

Item	Part No.	Description	Qty.
1	40-514-060	Weldment, frame	1
2	40-514-016	Frame, casting, arm	2
3	15-112-014	Pin, clevis, 1" x 4 1/2"	2
4	65125	Cotter pin, zinc plated, 3/16" x 1 1/2"	6
5	40-514-059	Weldment, gripper bracket	1
6	30-001-213-001	Load binder without hooks	1
7	40-112-013	Pin, gripper guide	1
8	40-113-009	Spacer	2
9	33018	USS flat washer, zinc plated, 3/4"	6
10	40-146-003	Spring, compression	2
11	40-537-007	Weldment, spring stopper	2
12	36109	Hex nut, gr. A, plain finish, 1/2"-13	4
13	40-516-009	Hinge, casting, gripper, left	1
14	40-516-010	Hinge, casting, gripper, right	1
15	08-145-028	Restraining/safety strap	1

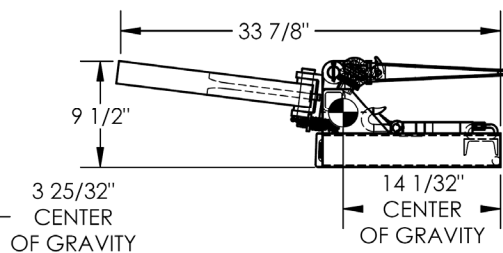
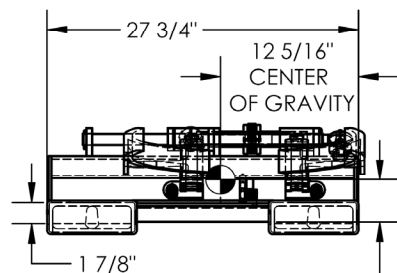
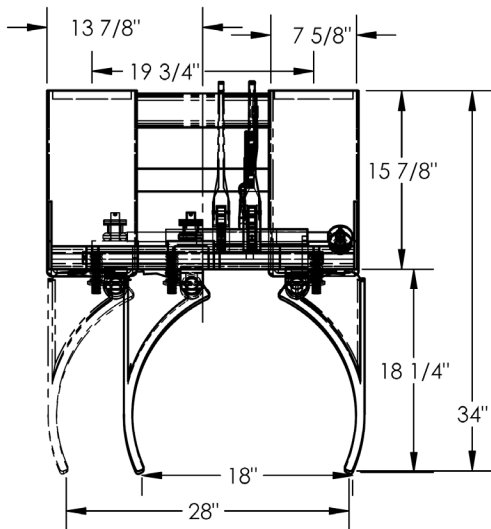

Specifications:

Manual, ratcheting drum clamp mechanism

Compatible with open and closed head drums made of steel and plastic. Open head drums must have lids properly & securely attached.

Capacity varies with drum material:

Steel = 1,500 lb. (681.8 kg)

Plastic = 1,000 lb. (454.5 kg)

Arm spacing adjustable from 18" to 28"

Arms pivot about a horizontal axis to fold onto the frame for storage

Distance between fork tube centers = 19 3/4"

Usable fork tube dimensions = 7 5/8" W x 1 7/8" H

DGD-A parts diagram and bill of materials

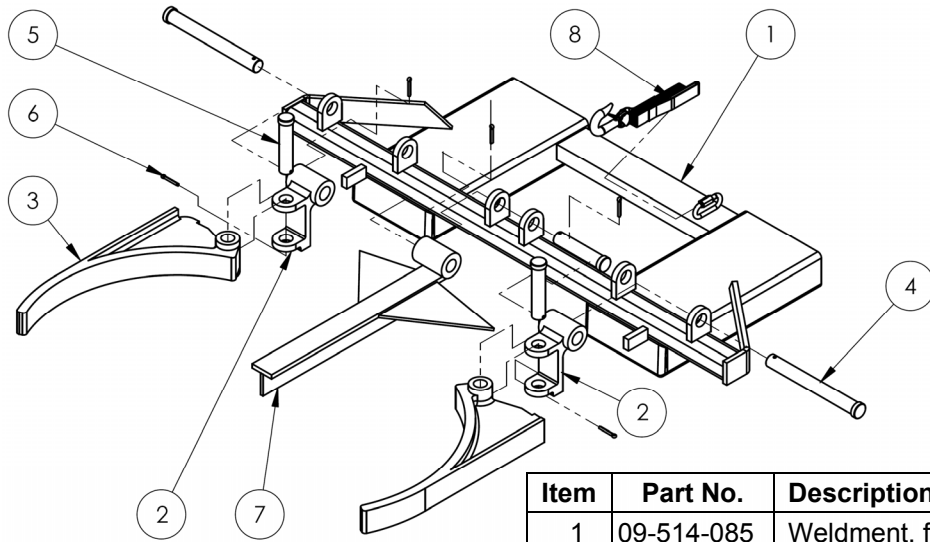

Item	Part No.	Description	Qty.
1	09-514-085	Weldment, frame, base	1
2	40-012-012	Hinge, casting, arm	2
3	40-514-016	Frame, casting, arm	2
4	40-112-001	Pin, main, clevis	2
5	15-112-014	Pin, clevis, 1" x 4 ¹ / ₂ "	3
6	65125	Cotter pin, zinc plated, ³ / ₁₆ " x 1 ¹ / ₂ "	5
7	09-514-086	Frame, weldment, middle attachment	1
8	08-145-028	Restraining/safety strap	1

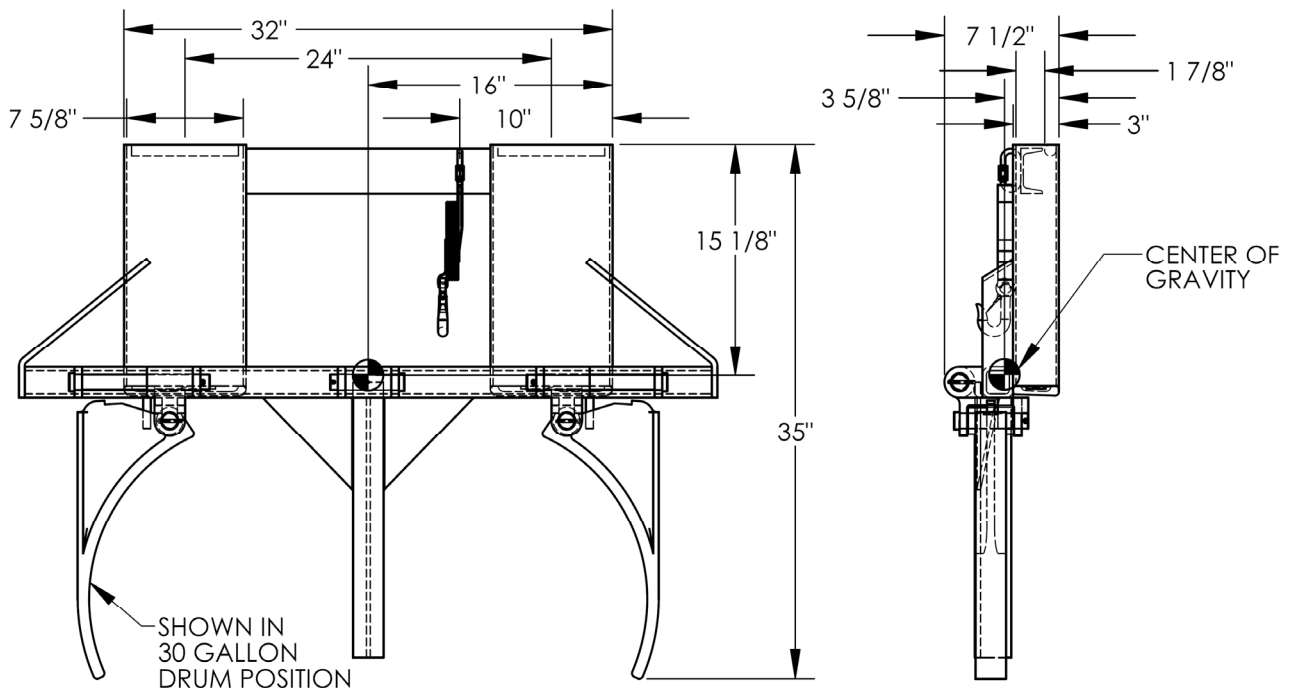

Specifications:

Compatible with 30gal. and 50gal. steel drums only.
 Drums may be open or closed head. Open head drums must have lids properly and securely fastened.

Capacity = 1,500 lb. (681.8 kg)

Arms pivot about a horizontal axis to fold onto the frame for storage.

Distance between fork tube centers = 24"

Usable fork tube dimensions = 7⁵/₈"W x 1⁷/₈"H

Using the drum carrier:

Standard DGS and DGD model drum carriers are designed to be used in non-classified, general industry locations. They should not be used to transport hazardous wastes.

Step 1: Adjust the positions of the forks on the carriage of your lift truck to match the fork tubes. Drive the forks into the fork tubes. Mount the drum lifter on the forks of your lift truck by slowly driving forward until the forks contact the ends of the pockets. Wrap the free end of the strap around the fork carriage. Attach the hook either to the strap or to the carriage. There must be no slack in the strap. Slack in the strap could allow the lifter to slide off the forks if, for instance, you brake suddenly. The strap must not be able to disconnect from the carriage.

Step 2: Open the arms of the carrier.

a) DGS-A & DSD-A: Raise the forks and tilt the mast forward to spread the arms slightly. Rim

b) DGS-AG: Raise the forks. Adjust the mast tilt to make the gripper arms parallel to the floor. The left and right gripper hinges (see items 13 and 14 on p. 4) must not touch the cross support. Adjust mast tilt, if necessary. Move the ratchet handle back-and-forth a few times. Grasp one of the receivers during the back stroke to allow the handle to ratchet backwards. If the arms are moving closer together, then press down the top of the pawl to reverse directions. Move the handle back-and-forth until the arms are wide apart enough to fit around the drum.

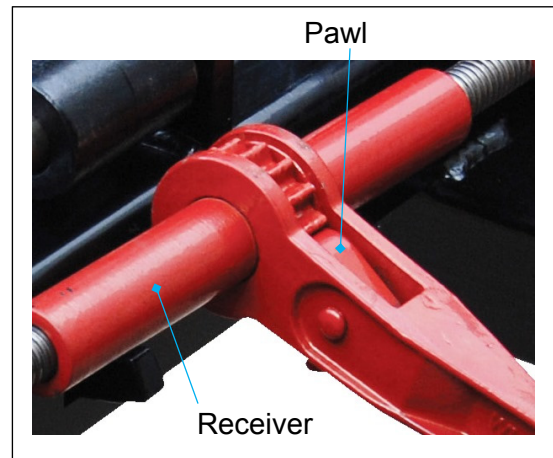

Step 3: Engage the drum.

a) DGS-A & DGD-A: Elevate the forks and adjust position so that the gripper arms are above the drum. Slowly lower the forks to bring the gripper arms over the top of the drum. Continue lowering the forks. The gripper arms will slide down the side of the drum. Position the arms below the first rolling hoop.

b) DGS-AG: Make sure that the arms are far enough apart to fit around the drum. Drive toward the drum with the drum between the arms. Stop when the drum contacts the back of the gripper arms. Adjust the height of the forks to bring the top sides of the arms into contact with the top rolling hoop (of the drum). Park the fork lift. Move the handle back-and-forth to bring the gripper arms into firm contact with the side of the drum. **NOTE: Do not overtighten the arms, particularly when clamping plastic and fiber drums.**

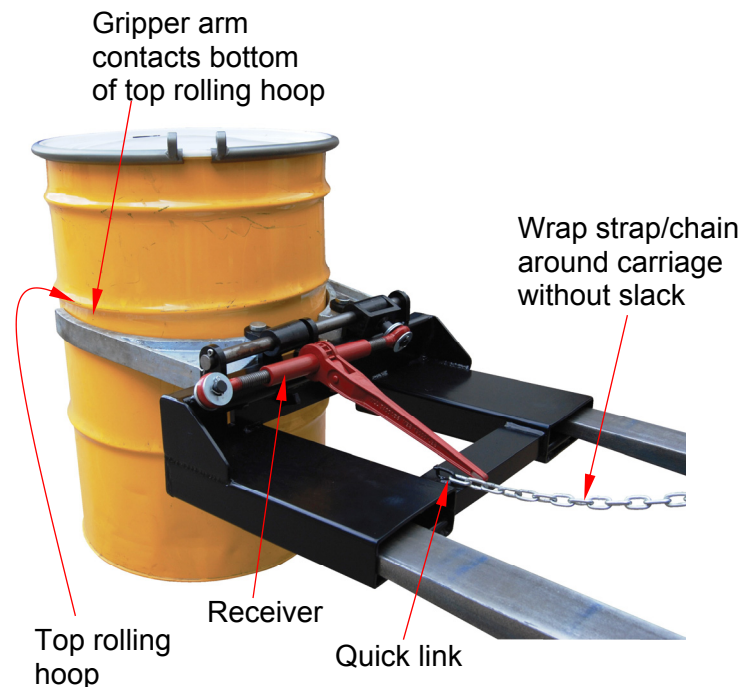

Step 4: Raise the forks.

a) DGS-A & DGD-A: Elevate the drum just a few inches above the ground. Tilt the mast back slightly.

b) DGS-AG: Elevate the forks sufficiently to raise the drum a few inches above the ground.

Step 5: Transport the drum to the necessary location. Turn slowly and brake gradually. Stopping suddenly might cause the carrier to slide on the forks or disrupt the clamp on the drum.

Step 6: Release the drum.

a) DGS-A & DGD-A: Tilt the mast forward. Slowly lower the forks until the entire bottom drum rim rests on the ground. Carefully back away from the drum until the gripper arms are completely free of the drum.

b) DGS-AG: Lower the forks until the entire lower drum rim rests on the ground. Reverse the pawl. Move the handle back-and-forth to release the clamp on the drum. Grasp one of the receivers during each backstroke.

Inspections & Maintenance:

Regular inspections and maintenance are necessary for the drum carrier to remain in normal condition. Before using it for the first time, create a written description of the appearance of the drum grippers, hinges, ratchet mechanisms (DGS-AG only) pins, fork pockets, the safety strap and quick link, and the frame. Install the lifter on the forks of your forklift and lift a drum. Record your observations about how the gripping mechanism engages the drum. Lower the drum and record your observations. This written record establishes “normal condition”. When conducting future inspections compare those observations to the written record to determine whether a component is in normal condition.

Before each use, inspect the following components. Replace any component that is not in normal condition before returning the carrier to service.

1. Safety strap, quick link, and hook (attached to the free end of the safety chain): confirm that the quick link is undamaged and welded securely to the frame. The hook should not be bent, stretched, cracked, or otherwise damaged. Check the strap for cuts, tears, etc.
2. Gripper arms and hinge castings: confirm that both arms and hinge castings are not cracked or warped. Hinge castings should rotate smoothly to allow the arms to fold onto the frame for compact storage.
3. Labels: all labels should be readable and located as shown in “Labeling diagram” (below). If a label is unreadable or missing, contact Vestil to order a replacement.
4. Fasteners (hardware): examine all bolts, nuts, washers, pins, and cotter pins.
5. Frame and fork tubes: confirm that each pocket is structurally sound, i.e. free of significant rusting/corrosion. Confirm that all welds are intact. The frame should be square and rigid and free of rust and corrosion. Remove rust with steel wool. Clean the affected area and apply touchup paint. Remove dirt and debris.

Labeling diagram:

The drum lifter should always be labeled as shown in the diagram below. Replace any label that is missing, damaged, or not easily readable (faded, for example).

NOTE: Labels and label locations are subject to change without notice.

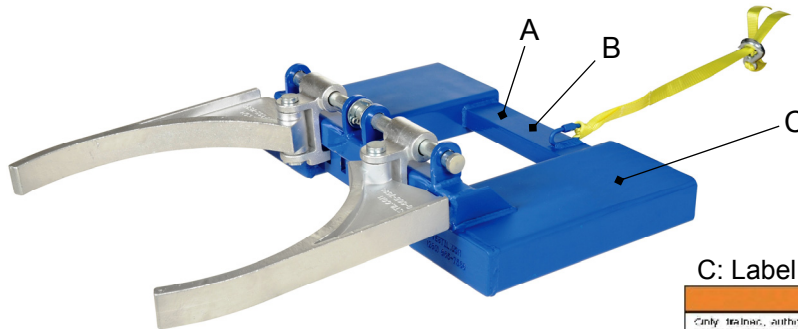

A: Label 218 (on fork pocket)

⚠ WARNING	⚠ ADVERTENCIAS
Improper use might result in death or serious personal injury. Attach device to fork carriage with safety chain/strap. <ul style="list-style-type: none"> • Drive lift truck forward until forks contact ends of fork pockets • Chain/straps must not be able to disconnect (slide free) from carriage. • Safety chain/strap must be taut. Connect chain/strap to carriage via shortest line. 	El uso inapropiado puede resultar en muerte o heridas personales. Atar aparato al mástil del montacargas con cadenas/correas. <ul style="list-style-type: none"> • Maneje el montacargas para adelante hasta que las cuñas hagan contacto con la orilla del bolsillo de las cuñas. • La cadenas y correas no deben de deslizarse (soltarse) del mástil del montacargas. • La cadena/correa de seguridad debe de estar apretado. Asegure la cadena/correa al mástil vía la ruta mas corta.

B: Label 287 (on fork pocket)

MODEL/MODÉLO/MODÈLE _____
STATIC CAPACITY (evenly distributed) _____ lbs.
LA CAPACIDAD CONSTANTE (distribuida uniformemente) _____ kgs.
CAPACITÉ STATIQUE (distribuée régulièrement) _____ kgs.
SERIAL/SERIE/SÉRIE _____
287 REV 0812

C: Label 527

⚠ WARNING

Only trained, authorized persons should operate this device. Improper operation might result in death or serious injury. Consulted by the truck operator and/or bystanders. Operators must observe the following safety instructions:

- **BEFORE** operating, inspect mast, carriage, forks/deck, cab/chain, wheels, and brakes for damage. **DO NOT** use if damaged.
- **ALWAYS** walk away path before using truck to identify hazards.
 - ✓ **DO NOT** contact electrical lines or overhead objects with device or load.
 - ✓ **DO NOT** travel up/down inclines if an alternate route is available.
 - ✓ **DO NOT** travel over debris.
- **ONLY** travel with forks/deck in lowest position appropriate for conditions.
- **ALWAYS** center and evenly distribute loads on forks/deck.
- **ALWAYS** secure load to forks/deck.
- **ONLY** drive on operator side/furthest from operator position.
- **DO NOT** exceed maximum rated load (capacity).
- **DO NOT** allow people to ride on device.
- **DO NOT** lift loads over people. **DO NOT** permit people to walk beneath the forks/deck when raised (loaded or unloaded).
- **DO NOT** leave unattended UNTIL fully closed AND unloaded.
- **DO NOT** modify device in any way.

⚠ ADVERTENCIA

Solo personas entrenadas y autorizadas deben operar este equipo. Las operaciones inadecuadas podría resultar en casos serios al operador o del camión y/o a los transeúntes. Los operadores deben observar y seguir las siguientes instrucciones de seguridad:

- **ANTES** de usar, inspeccionar el mástil, el equipo, las horcas, el platón/mástil, cables/cadenas, ruedas y frenos por daños. **NO** usar si se observan daños.
- **SIEMPRE** caminar el trayecto de viaje antes de usar el camión para identificar riesgos:
 - ✓ **NO** tocar las líneas eléctricas u objetos altos con el dispositivo o la carga.
 - ✓ **NO** viajar un inclinador ni hacia arriba ni bajado, si hay otra ruta alternativa.
 - ✓ **NO** viajar sobre escombros.
- **NO** viajar con las horcas/deck elevadas en la posición adecuada para las condiciones para las condiciones.
- **SIEMPRE** centrar y distribuir las cargas uniformemente en las horcas/deck/platón/mástil.
- **SIEMPRE** asegurar la carga a las horcas/deck/platón/mástil.
- **SOLO** conducir u operar las funciones del camión desde la posición del operador.
- **NO** exceder la capacidad máxima basada de carga.
- **NO** permitir que le gente se monte en el equipo.
- **NO** elevar las cargas sobre la gente. **NO** permitir que la gente camine debajo de las horcas/deck/mástil cuando están elevadas (con carga o sin carga).
- **NO** dejar el equipo desatendido de **HASTA** que esté completamente cerrado y descargado.
- **NO** modificar el equipo de ninguna manera.

VESTIL MANUFACTURING CORPORATION
Phone (250) 667-7886 • www.vestil.com 527-1 Rev 1/18

LIMITED WARRANTY

Vestil Manufacturing Corporation (“Vestil”) warrants this product to be free of defects in material and workmanship during the warranty period. Our warranty obligation is to provide a replacement for a defective original part if the part is covered by the warranty, after we receive a proper request from the warrantee (you) for warranty service.

Who may request service?

Only a warrantee may request service. *You are a warrantee if* you purchased the product from Vestil or from an authorized distributor AND Vestil has been fully paid.

What is an “original part”?

An original part is a part used to make the product as shipped to the warrantee.

What is a “proper request”?

A request for warranty service is proper if Vestil receives: 1) a photocopy of the Customer Invoice that displays the shipping date; AND 2) a written request for warranty service including your name and phone number. Send requests by any of the following methods:

Mail
Vestil Manufacturing Corporation
2999 North Wayne Street, PO Box 507
Angola, IN 46703

Fax
(260) 665-1339
Phone
(260) 665-7586

Email
sales@vestil.com

In the written request, list the parts believed to be defective and include the address where replacements should be delivered.

What is covered under the warranty?

After Vestil receives your request for warranty service, an authorized representative will contact you to determine whether your claim is covered by the warranty. Before providing warranty service, Vestil may require you to send the entire product, or just the defective part or parts, to its facility in Angola, IN. The warranty covers defects in the following original dynamic components: motors, hydraulic pumps, electronic controllers, switches and cylinders. It also covers defects in original parts that wear under normal usage conditions (“wearing parts”), such as bearings, hoses, wheels, seals, brushes, and batteries.

How long is the warranty period?

The warranty period for original dynamic components is 90 days. For wearing parts, the warranty period is 90 days. The warranty periods begin on the date when Vestil ships the product to the warrantee. If the product was purchased from an authorized distributor, the periods begin when the distributor ships the product. Vestil may, at its sole discretion, extend the warranty periods for products shipped from authorized distributors by *up to* 30 days to account for shipping time.

If a defective part is covered by the warranty, what will Vestil do to correct the problem?

Vestil will provide an appropriate replacement for any covered part. An authorized representative of Vestil will contact you to discuss your claim.

What is not covered by the warranty?

1. Labor;
2. Freight;
3. Occurrence of any of the following, which automatically voids the warranty:
 - Product misuse;
 - Negligent operation or repair;
 - Corrosion or use in corrosive conditions;
 - Inadequate or improper maintenance;
 - Damage sustained during shipping;
 - Accidents involving the product;
 - Unauthorized modifications: DO NOT modify the product IN ANY WAY without first receiving written authorization from Vestil. Modification(s) might make the product unsafe to use or might cause excessive and/or abnormal wear.

Do any other warranties apply to the product?

Vestil Manufacturing Corp. makes no other express warranties. All implied warranties are disclaimed to the extent allowed by law. Any implied warranty not disclaimed is limited in scope to the terms of this Limited Warranty.

