

VESTIL MANUFACTURING CORP.
 2999 N. Wayne St., Angola, IN 46703
 Ph: 260-665-7586 · Fax: 260-665-1339
 E-mail: sales@vestil.com · Website: www.vestil.com

OWNER'S MANUAL

DCR-205-XX-DC Powered Drum Rotators

Maintenance, Inspection, & Safety Checks	2	Labeling diagram	5
Operation Instructions	3	Electrical circuit diagram	6
Exploded Parts Diagram/Bill of Materials	4	Limited warranty	7

IMPORTANT NOTES, WARNINGS AND SAFETY INSTRUCTIONS

Ensure that all employees understand and follow the following.

- ☞ Failure to read and understand this owner's manual before using or servicing the drum carrier/rotator constitutes a misuse of the product. All persons who will install, use, or care for this product must be familiar with this material.
- The load must be removed from the drum saddle before any work is performed on the drum carrier/rotator.
- Ensure that all information / safety / warning labels stay in place and are legible.
- Do not use the drum carrier/rotator if any damage, unusual noise, or unusual motion is observed; if it is in need of repairs, or; if it seems to be malfunctioning. Notify your supervisor or maintenance personnel if you notice anything out of the ordinary.
- Always watch the drum it's contents carefully when the drum carrier/rotator is in operation.
- Before transporting the drum carrier/rotator, raise the fork trucks forks high enough that the product and its load are raised off the ground slightly. Transport the drums as close to the ground as is possible without letting them drag.
- The drum carrier/rotator is intended for use only with adequately-rated fork trucks or counterbalanced pallet trucks being operated on improved, compacted, and level surfaces.
- Do not use brake fluid or jack oils in the hydraulic system. If oil is needed, use an anti-wear hydraulic oil with a viscosity grade of 150 SUS at 100°F, (ISO 32 cSt @ 40°C), or Dexron transmission fluid.
- Contact the manufacturer for any needed MSDS information.
- ◆ Do not perform any modifications to the drum carrier/rotator without the manufacturer's approval. Failure to receive authorization for changes to the equipment could void the warranty.
- ◆ Maintenance and repairs are to be done only by personnel qualified to perform the required work. Consideration will not be given for warranty repair charges without prior written authorization by the manufacturer.



ORDERING REPLACEMENT

PARTS:

We take pride in using quality parts on the equipment we manufacture. We are not responsible for equipment problems resulting from the use of unapproved replacement parts.

To order replacement or spare parts for this equipment, contact the factory.

In any communication with the factory please be prepared to provide the machine's serial number, which is indicated on the machine dataplate.

RECEIVING INSTRUCTIONS

It is possible that this product could incur damage during transit.

Inspect the unit closely when it arrives. *If you see evidence of damage or rough handling to either the packaging or to the product when it is being unloaded, **immediately** make a note of it on the Bill Of Lading!*

It is important that you remove the product's packaging upon its arrival to ensure that there is no concealed damage or to enable a timely claim with the carrier for freight damage.

Also verify that the product and its specifications are as ordered.

MAINTENANCE, INSPECTION, & SAFETY CHECKS - DCR-205-XX-DC

- *Warning: Care should be taken to identify all potential hazards and comply with applicable safety procedures before beginning work.*
- *Only individuals qualified to understand the mechanical design aspects and the associated hazards of this type of equipment should attempt to troubleshooting and/or repair it.*

The model DCR-205-xx-DC drum carrier/rotator is equipped with two (2) 12 volt, 35 ampere-hour, sealed, maintenance-free AGM-type batteries to provide a 24 VDC power supply to the rotation system's drive motor and motor control components.

The unit is supplied with an on-board 24V, 3 ampere battery charger which will typically fully recharge the batteries in about eight (8) hours. The charger is powered by attaching the connector end of most any three-prong extension cord to the flanged inlet located in the top of the gray plastic battery department cover. The charger can be left on indefinitely without causing harm to the batteries.

Do not use an extension cord smaller than 18 gauge, or longer than fifty (50) feet, to power the battery charger.

The touchpad located on the front of the gray battery compartment cover indicates the approximate state of charge of the batteries, and is shown as a percentage of full charge based on the batteries' combined voltage.

When the batteries are fully charged, approximately 200 full raise/lower cycles can be expected before the batteries will need to be recharged. Charge the batteries overnight at least every two (2) weeks even if it is not in use.

If it will not be used for several weeks or longer, it is advisable to remove the batteries from the machine.

Inspect daily for:

- 1.) Damage to the product's securing chain or web strap.
- 2.) Damage or structural deformation to the structural members.
- 3.) Unusual noise or binding, or evidence thereof.

Inspect monthly for:

- 1.) Pivot point wear.
- 2.) Looseness and wear of the gears, sprockets, chains, hinge points, component mounts, etc.
- 3.) Integrity of the retaining hardware on all rollers and on all pivot point pins.
- 4.) Proper functioning of drum saddle's locking mechanism.
- 5.) Unusual noises or movement during operation.
- 6.) All the information/safety/warning labels being in place and in good condition.
- 7.) The need to clean off dirt and debris.

Test the battery voltage. In order to get an accurate indication of the batteries' state of charge, the reading must be taken at least two hours after the charger has been turned off after having completed a full (8 hour) charge cycle. The batteries will read 12.65 volts when fully charged.

With the exception of the gearmotor, lubricate all of the gear-train grease fittings once a month with a good grade of industrial grease. Otherwise, periodically lubricate the cradle hinges, the drum saddle's ratchet and pawl mechanism, and the chains.

Yearly inspection:

If possible, test the product with a full load. Afterward, inspect for:

- 1.) Cracks at weld joints.
- 2.) Deformation or bending of any parts, or wrinkled or cracked paint which could indicate the same.

OPERATION INSTRUCTIONS - DCR-205-xx-DC

- Consult ANSI B56.1 for the owner's / user's responsibilities regarding the operation, care, and maintenance of this machine.
- Ensure that all employees involved in the operation of this drum carrier/rotator understand and follow these instructions!

The standard model DCR-205-xx-DC is suitable for transporting standard closed 55-gallon steel drums in most non-Classified indoor and outdoor locations. It is intended to be used to transport and dump non-Classified liquids.

Attaching the drum carrier/rotator to the forks of a lift truck:

The load rating, in pounds, is shown on the machine dataplate located on the frame of the drum carrier/rotator. It indicates the net capacity of the drum carrier/rotator when dumping a full liquid-filled drum. For drums that are only half-full, the net capacity that the unit will rotate drops to 500 lbs.

The truck's forks must be adjusted to have at least 24½" between them, and one fork must be locked in place to the truck mast's fork carriage.

Insert the fork truck's forks into the fork pockets until the ends of the forks contact the drum carrier/rotator's fork tube end caps.

Open the drum carrier/rotator's saddle and secure it open by attaching the hook cradle chain to ????

With its forks near the floor, drive the lift truck forward until the back side of the drum saddle is against the side of the drum. The saddle should be positioned at or just above the center of the drum, but not against one of the drum's rings.

Close the drum saddle's gate and secure the chain to the chain slot. Lock the drum in place by rotating the drum saddle's gate handle 90° clockwise. Grasp and shake the top of the drum to ensure that it is securely held.

Do not exceed a rate of three feet per second (2 mph) when transporting drums with the drum carrier/rotator.

Warning: Do not exceed the drum carrier/rotator's load ratings. Injury to personnel, or permanent damage to the drum carrier/rotator, the drum, or the drum's contents could result from exceeding the listed capacity.

Operation of the drum carrier/rotator:

On a daily basis, inspect the safety chain or web strap that is used to secure the product to the fork truck's mast.

Warning: Keep all personnel clear of the drum carrier/rotator when it is in operation. Be certain no part of any person or object is under any part of the drum before lowering it or dumping its contents.

Caution: Always watch the drum it's contents carefully when the drum carrier/rotator is in operation.

Caution: Do not use the drum carrier/rotator if any damage, unusual noise, or unusual motion is observed; if it is in need of repairs, or; if it seems to be malfunctioning. Notify your supervisor or maintenance personnel if you notice anything out of the ordinary.

The model DCR-205-xx-DC drum carrier/rotator is operated by means of a pushbutton control connected to a coiled retractile cord. The speed is controlled by a touchpad located on the front of the gray plastic battery department cover.

Manual operation: The drum carrier/rotator can also be operated manually using the crank handle that came with the unit. To use the hand crank, the chain connecting the gearmotor to the drive shaft will need to be removed, and the hollow shaft of the crank handle is to be inserted onto the square end of the drive shaft.

Ensure that all information/safety/warning labels stay in place and are legible. Refer to the labels page in this manual.

Exploded part diagram and bill of materials

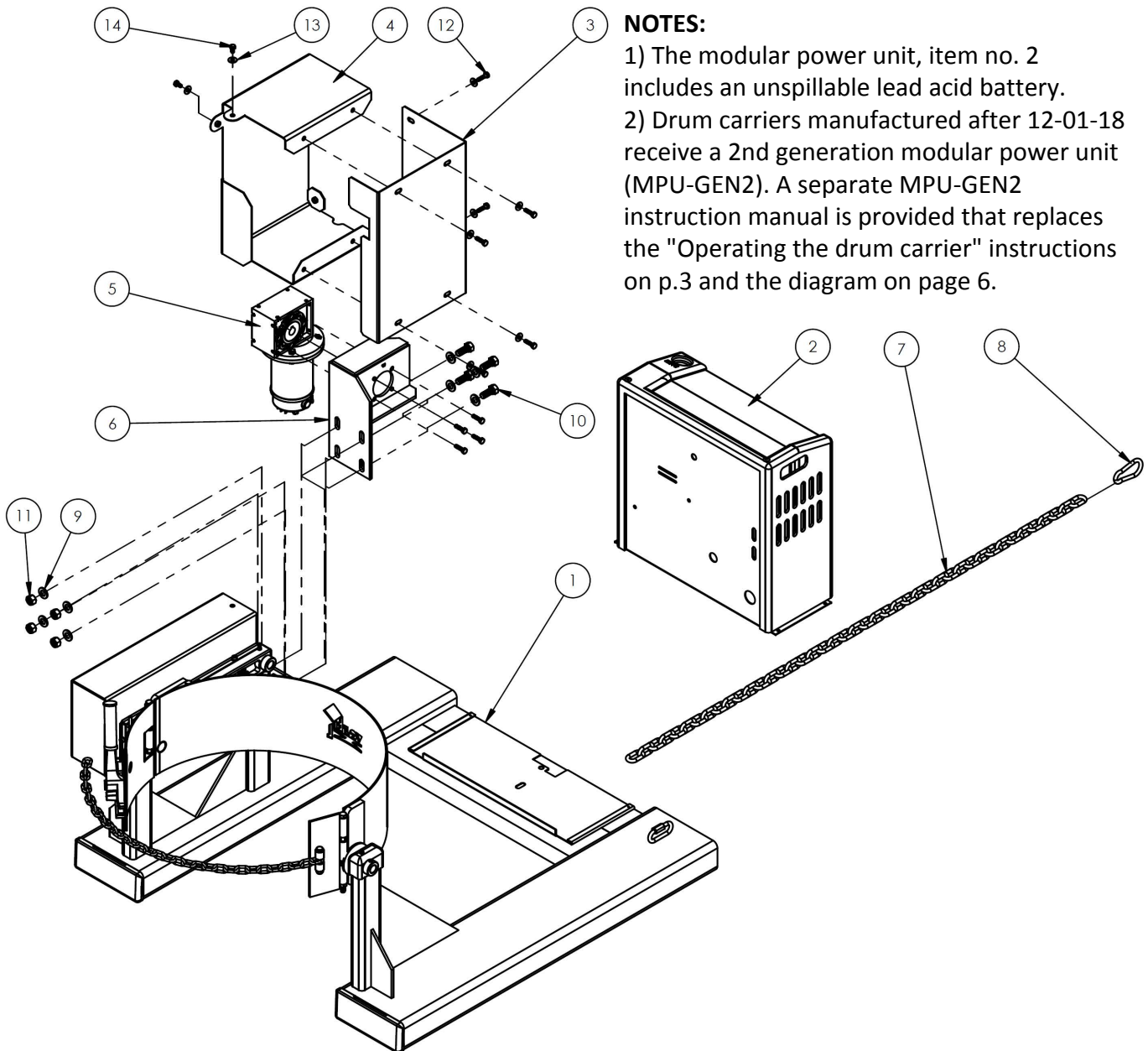
**NOTES:**

- 1) The modular power unit, item no. 2 includes an unspillable lead acid battery.
- 2) Drum carriers manufactured after 12-01-18 receive a 2nd generation modular power unit (MPU-GEN2). A separate MPU-GEN2 instruction manual is provided that replaces the "Operating the drum carrier" instructions on p.3 and the diagram on page 6.

Item	Part	Description	Qty.	Item	Part	Description	Qty.
1	09-514-164	Weldment, frame & saddle	1	8	08-145-041	Snap hook, $\frac{5}{16}$ "	1
2	99-158-001	Modular power unit, DC	1	9	33011	Flat washer, USS, plain finish, $\frac{1}{2}$ "	8
3	09-024-018	Guard, motor shroud, formed	1	10	11207	Bolt, $\frac{1}{2}$ "-13x $\frac{1}{4}$ ", HHCS, #2, zinc-plated	4
4	09-524-003	Guard, weldment, motor shroud	1	11	36110	Hex nut, $\frac{1}{2}$ "-13, zinc-plated	4
5	21-641-005	Motor with gearbox, shaft, & key stock	1	12	11005	Bolt, $\frac{1}{4}$ "-20UNCx1", HHCS, #2, zinc-plated	10
6	09-516-080	Bracket, weldment, motor mount	1	13	33004	Flat washer, USS, zinc-plated, $\frac{1}{4}$ "	8
7	09-145-018	$\frac{5}{16}$ " chain 56"	1	14	11001	Hex bolt, grade A, zinc plated, $\frac{1}{4}$ "-20x $\frac{1}{2}$ "	2

Labeling diagram:

The product should always be labeled as diagrammed below. Replace any label that is missing, damaged, or not easily readable (e.g. faded).

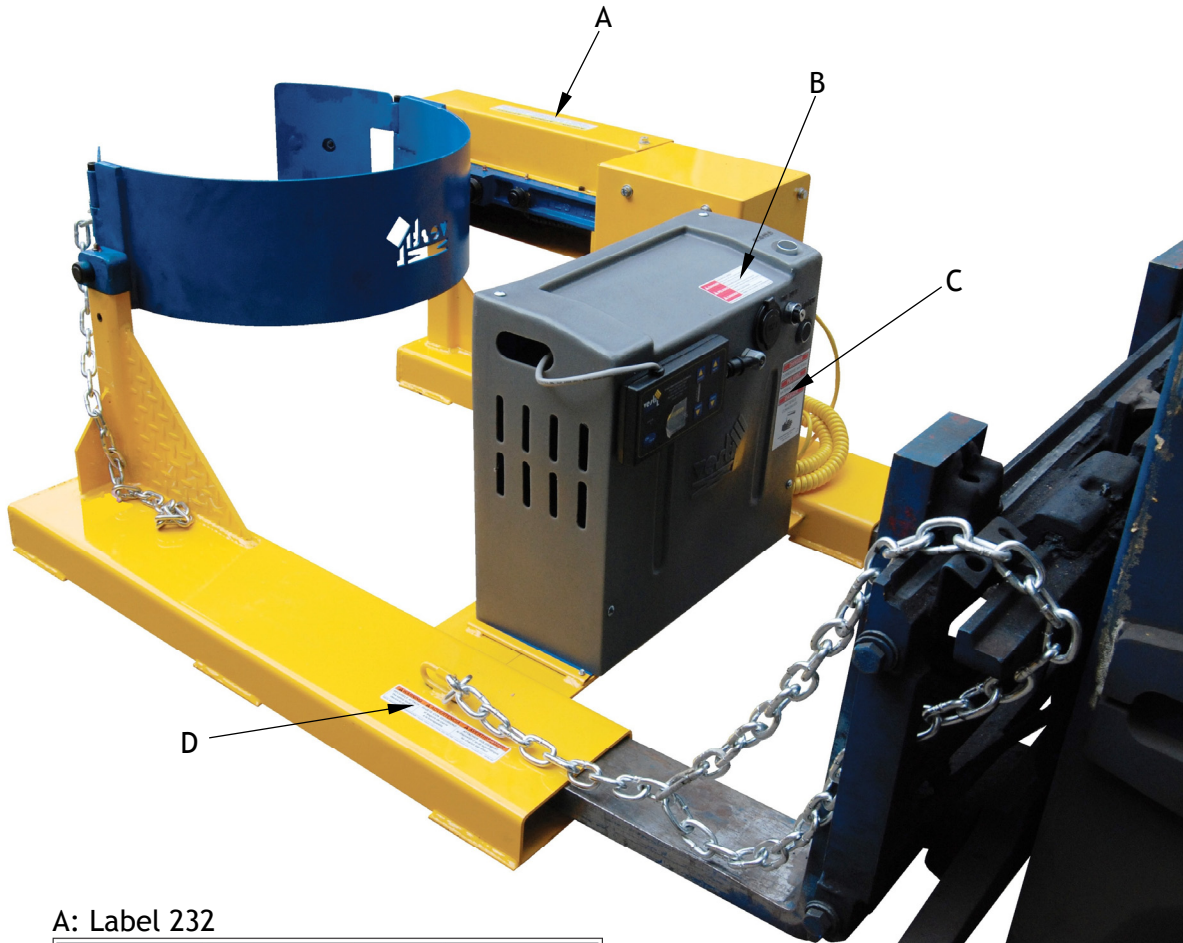

A: Label 232

⚠ CAUTION	⚠ ATENCIÓN	⚠ ATTENTION
DRUM MUST BE IN VERTICAL POSITION WHEN MOVING	EL TAMBOR DEBE DE ESTAR EN LA POSICIÓN VERTICAL CUANDO EN MOVIMIENTO	LE BIDON DOIT ÊTRE EN POSITION VERTICALE LORS D'UN DÉPLACEMENT
VESTIL MANUFACTURING CORPORATION • Phone (200) 665-7586 • Fax (200) 665-1339 • sales@vestil.com • www.vestil.com Revised 03/08		

B: Label 221

⚠ DANGER	ELECTRICAL SHOCK Shut power off and consult owners manual before working on this equipment.	221 Rev 0111
⚠ PELIGRO	EI GOLPE ELECTRICO Corte la corriente consulte el manual de propietario antes de trabajar en este equipo.	
⚠ DANGER	CHOC ELECTRIQUE Couper le courant et consulter le manuel d'utilisation avant de travailler sur cet équipement	

C: Label 295

⚠ WARNING
Enclosed battery contains hazardous chemicals. DO NOT handle enclosed battery UNLESS wearing eye protection and other appropriate personal protective equipment. DO NOT directly contact skin with battery. DO NOT expose to sparks or extreme heat; battery contains explosive gases.
⚠ ADVERTENCIA
La batería incluida contiene materiales peligrosos. NO use la batería incluida A NO SER que lleve protección de ojos y otros equipos de protección apropiados para el personal. NO tenga contacto directo en la piel con la batería. NO exponga a destellos o a calor excesivo, la batería contiene gases explosivos.

295 rev 0111

D: Label 218

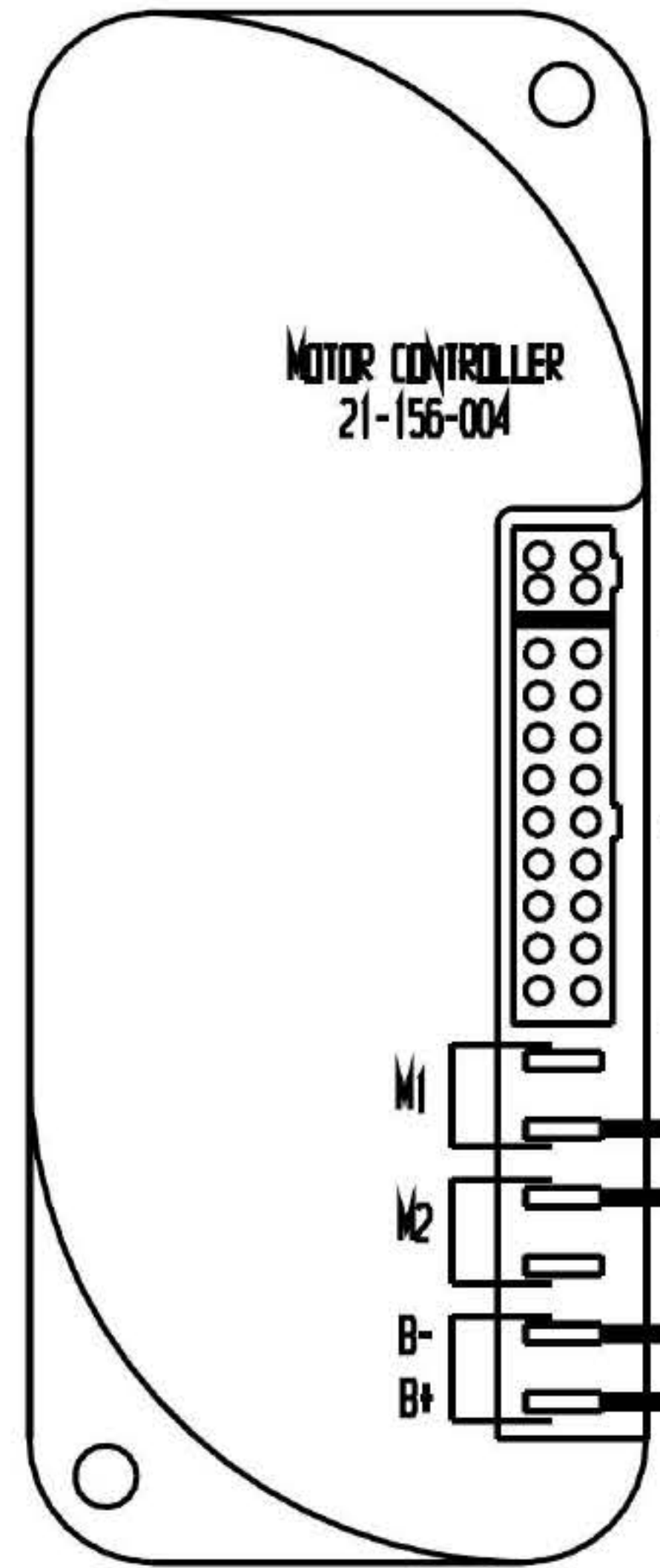
⚠ WARNING	⚠ ADVERTENCIAS
Improper use might result in death or serious personal injury. Attach device to fork carriage with safety chain/strap. <ul style="list-style-type: none"> • Drive lift truck forward until forks contact ends of fork pockets. • Chain/straps must not be able to disconnect (slide free) from carriage. • Safety chain/strap must be taut. Connect chain/strap to carriage via shortest line. 	El uso impropio puede resultar en muerte o heridas personales. Atar aparato al mástil del montacargas con cadenas/correas. <ul style="list-style-type: none"> • Maneje el montacargas para adelante hasta que las cuñas hagan contacto con la orilla del bolsillo de las cuñas. • La cadenas y correas no deben de deslizarse (soltarse) del mástil del montacargas. • La cadena/correa de seguridad debe de estar apretado. Asegure la cadena/correa al mástil via la ruta mas corta.
	218 rev 0910



TOUCHPAD WIRING HARNESS PLUGS INTO MOTOR CONTROLLER AND BATTERY CHARGER.

• LIMIT SWITCH WIRE COLORS -- NOT USED ON THE DCR-205-DC

COMPONENT	WIRE COLORS	
N.C. UPPER LIMIT SW	BLACK / WHITE	BLUE / WHITE
N.C. LOWER LIMIT SW	RED / WHITE	GREEN / WHITE

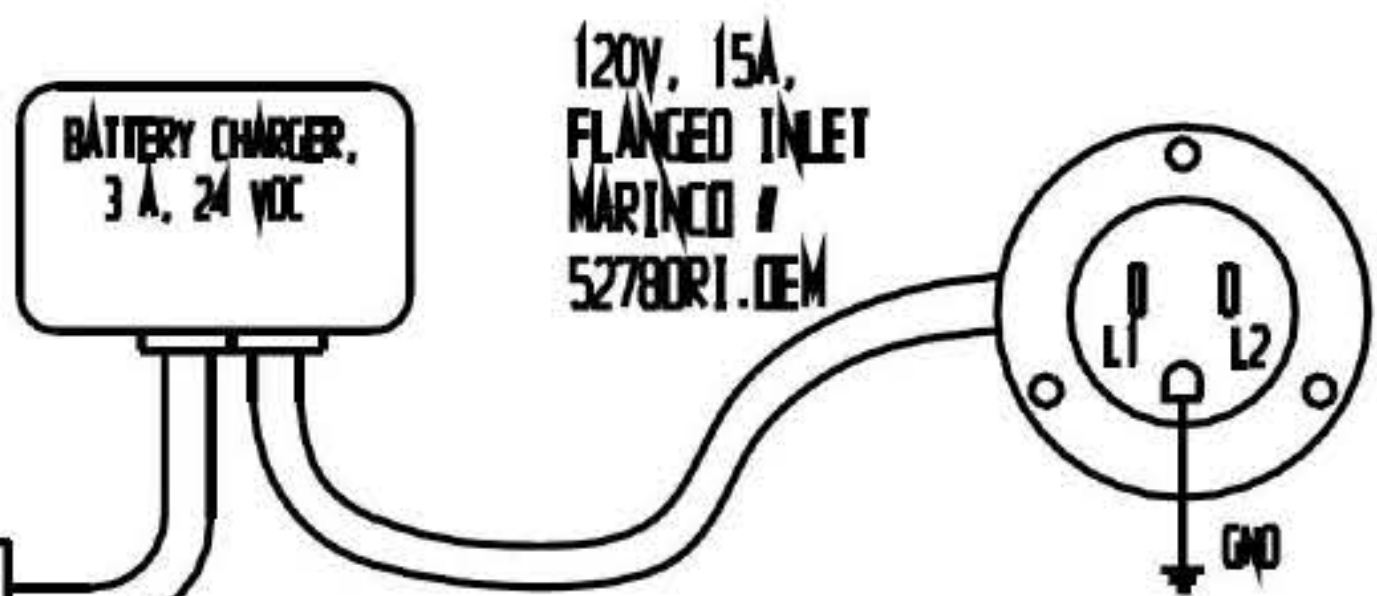

Note:
The touchpad will operate the drum rotator even when '1 KS' key switch is "OFF."

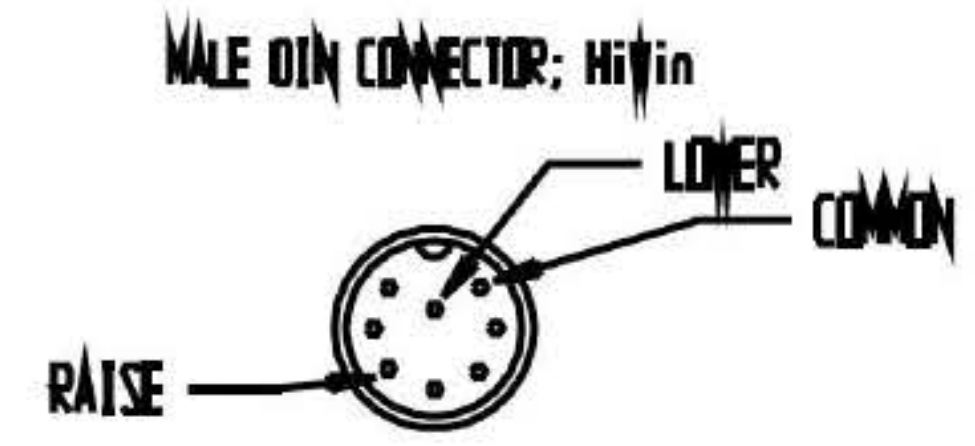
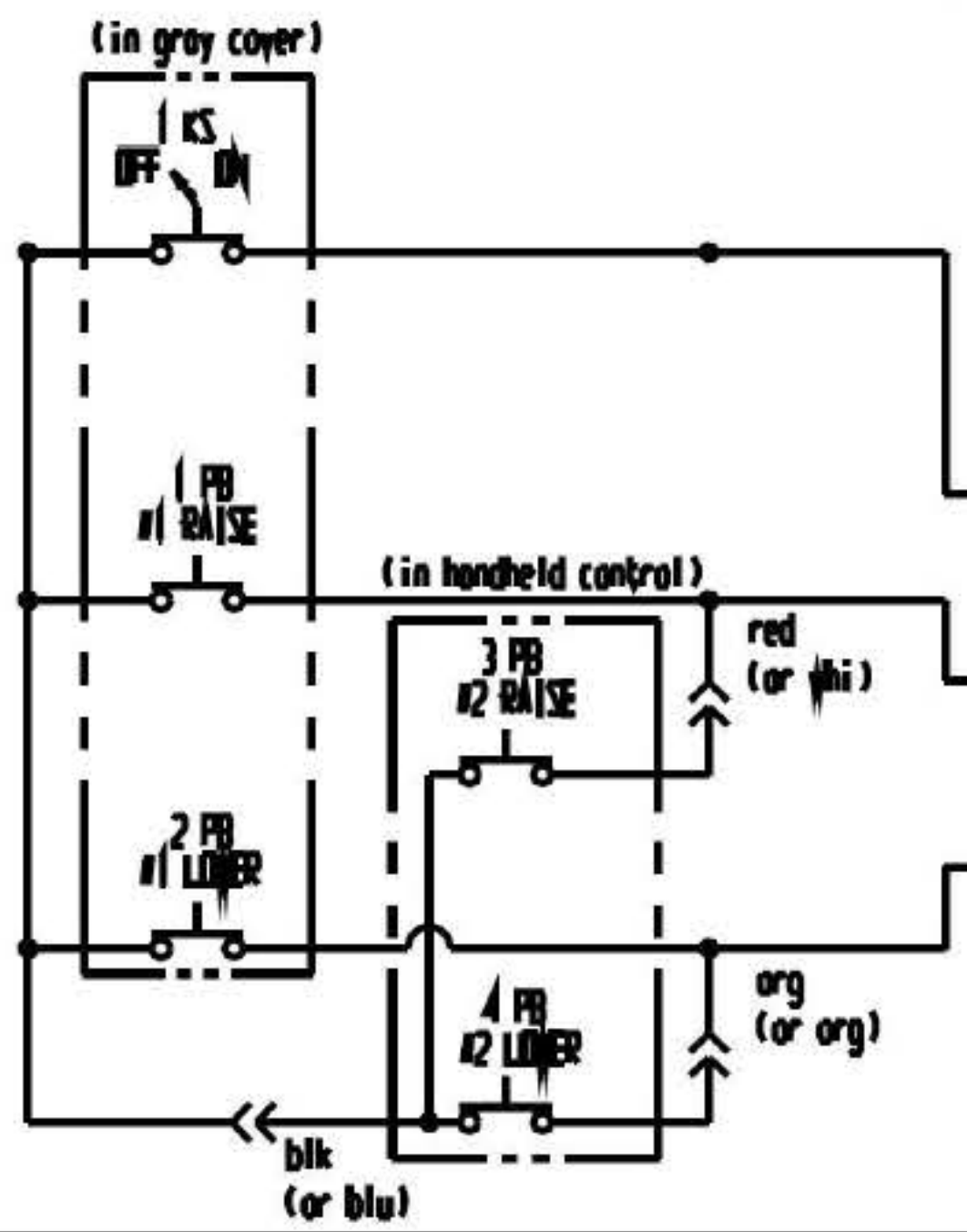
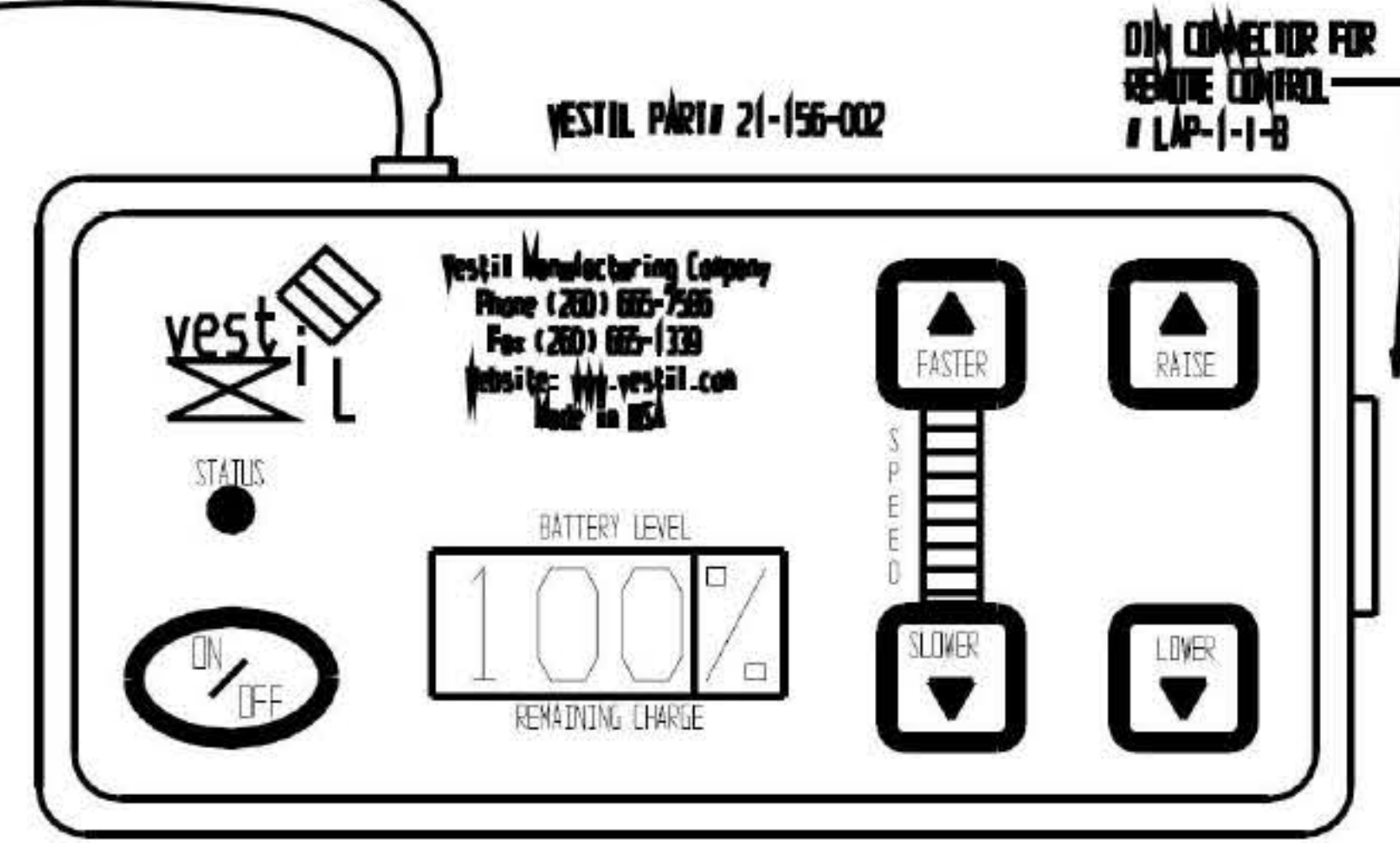
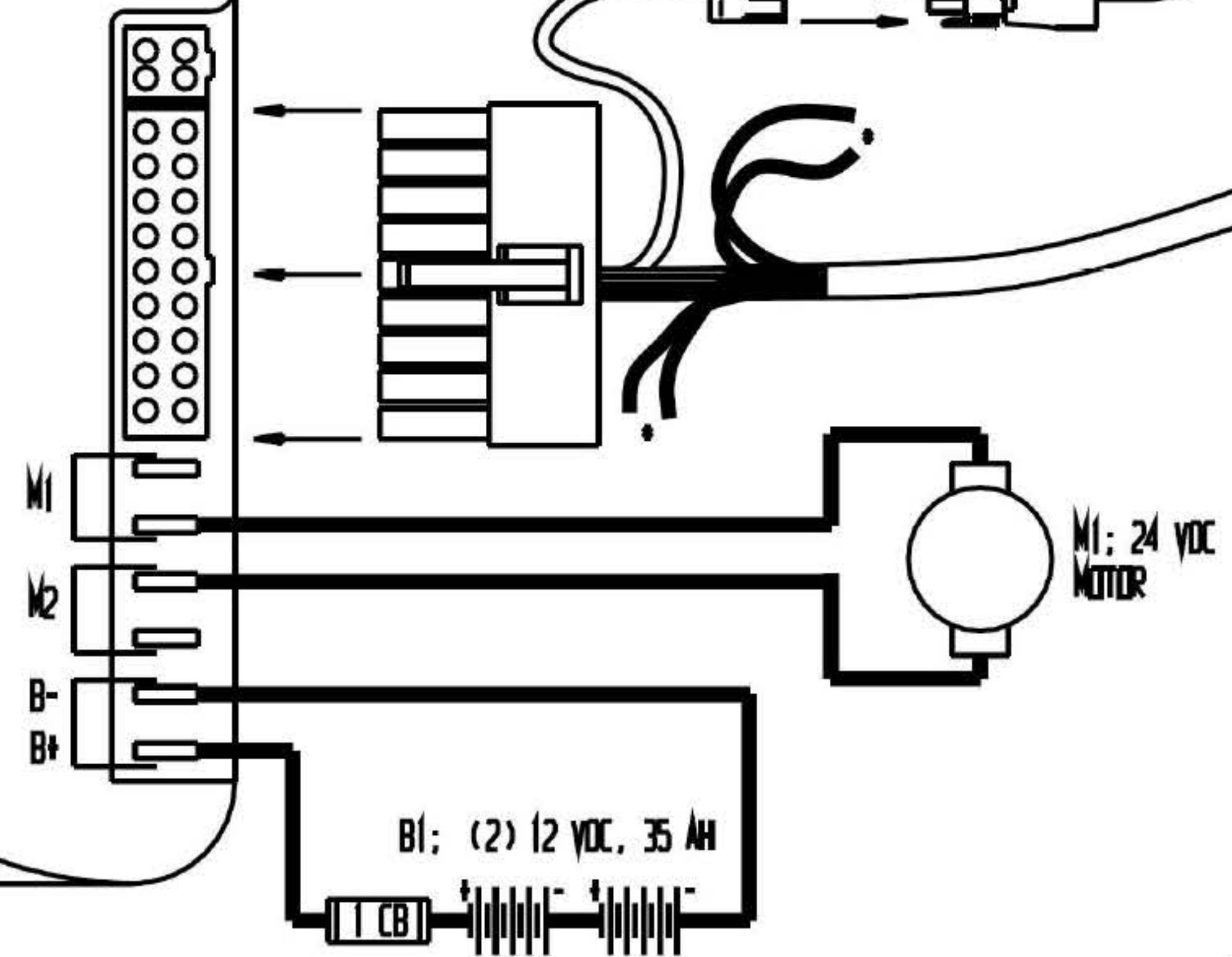

"RAISE" dumps the drum.
"LOWER" uprights the drum.

NOTES:

COMPONENT	PART NUMBER
MOTOR; M1	21-641-005
BATTERIES; B1	21-139-002
CIRCUIT BRKR; 1 CB	21-034-006
BATTERY CHARGER	21-034-010

These components are installed in the shell of the nodular power unit.

LIMITED WARRANTY

Vestil Manufacturing Corporation (“Vestil”) warrants this product to be free of defects in material and workmanship during the warranty period. Our warranty obligation is to provide a replacement for a defective original part if the part is covered by the warranty, after we receive a proper request from the warrantee (you) for warranty service.

Who may request service?

Only a warrantee may request service. *You are a warrantee if* you purchased the product from Vestil or from an authorized distributor AND Vestil has been fully paid.

What is an “original part”?

An original part is a part used to make the product as shipped to the warrantee.

What is a “proper request”?

A request for warranty service is proper if Vestil receives: 1) a photocopy of the Customer Invoice that displays the shipping date; AND 2) a written request for warranty service including your name and phone number. Send requests by any of the following methods:

<u>Mail</u>	<u>Fax</u>	<u>Email</u>
Vestil Manufacturing Corporation 2999 North Wayne Street, PO Box 507 Angola, IN 46703	(260) 665-1339 <u>Phone</u> (260) 665-7586	sales@vestil.com

In the written request, list the parts believed to be defective and include the address where replacements should be delivered.

What is covered under the warranty?

After Vestil receives your request for warranty service, an authorized representative will contact you to determine whether your claim is covered by the warranty. Before providing warranty service, Vestil may require you to send the entire product, or just the defective part or parts, to its facility in Angola, IN. The warranty covers defects in the following original dynamic components: motors, hydraulic pumps, electronic controllers, switches and cylinders. It also covers defects in original parts that wear under normal usage conditions (“wearing parts”), such as bearings, hoses, wheels, seals, brushes, and batteries.

How long is the warranty period?

The warranty period for original dynamic components is 90 days. For wearing parts, the warranty period is 90 days. The warranty periods begin on the date when Vestil ships the product to the warrantee. If the product was purchased from an authorized distributor, the periods begin when the distributor ships the product. Vestil may, at its sole discretion, extend the warranty periods for products shipped from authorized distributors by up to 30 days to account for shipping time.

If a defective part is covered by the warranty, what will Vestil do to correct the problem?

Vestil will provide an appropriate replacement for any covered part. An authorized representative of Vestil will contact you to discuss your claim.

What is not covered by the warranty?

1. Labor;
2. Freight;
3. Occurrence of any of the following, which automatically voids the warranty:
 - Product misuse;
 - Negligent operation or repair;
 - Corrosion or use in corrosive conditions;
 - Inadequate or improper maintenance;
 - Damage sustained during shipping;
 - Accidents involving the product;
 - Unauthorized modifications: DO NOT modify the product IN ANY WAY without first receiving written authorization from Vestil. Modification(s) might make the product unsafe to use or might cause excessive and/or abnormal wear.

Do any other warranties apply to the product?

Vestil Manufacturing Corp. makes no other express warranties. All implied warranties are disclaimed to the extent allowed by law. Any implied warranty not disclaimed is limited in scope to the terms of this Limited Warranty.

