

PROPANE CYLINDER STORAGE CABINETS- CYL-EX-12-S

APPROX WEIGHT: 227.92 lbs.
 DOES NOT INCLUDE WEIGHT OF POWER OR PACKAGING!!!

*** ANY ADDITIONS, DELETIONS, OR OMISSIONS MUST BE CORRECTED ON THIS DRAWING AS THIS DRAWING WILL BE CONSIDERED ALL INCLUSIVE ***

ALL GRAPHICS PROVIDED ARE FOR REFERENCE ONLY. IF CERTAIN DIMENSIONS ARE CRITICAL PLEASE VERIFY THOSE DIMENSIONS WITH YOUR SALESPERSON

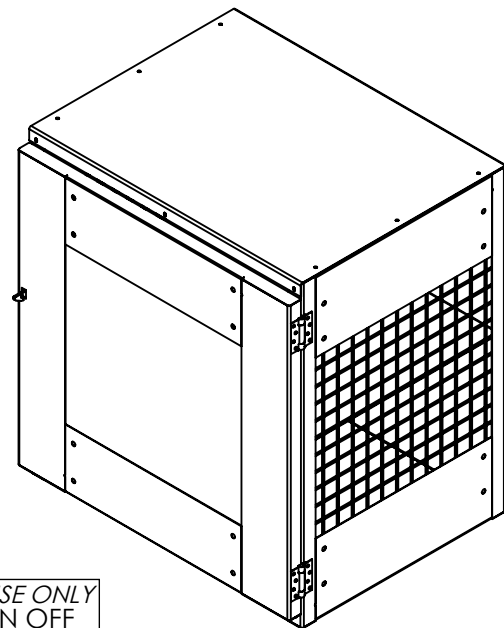
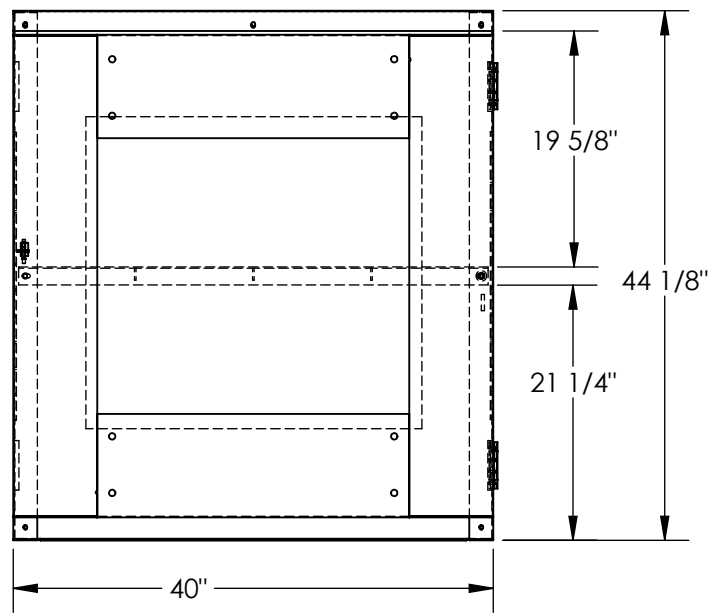
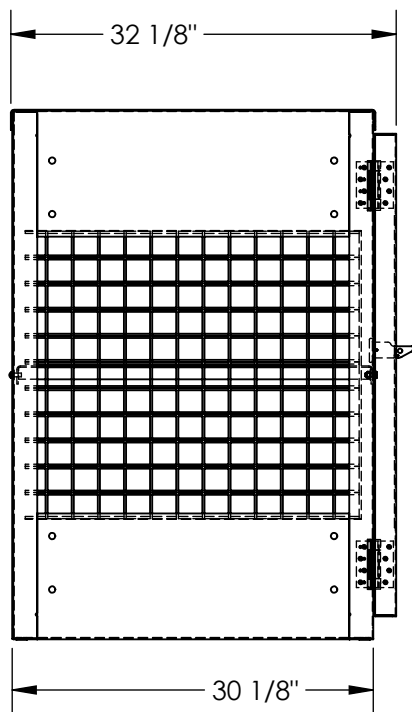

FOR INTERNAL USE ONLY
 PROJECT SIGN OFF

SALES	
ENG.	
FAB.	
POWER	

DIMENSION TOLERANCE ± 1/4"

LAG HOLE PATTERN
 Ø 1/2" x 3/4" LG
 SLOT
 4-PLACES

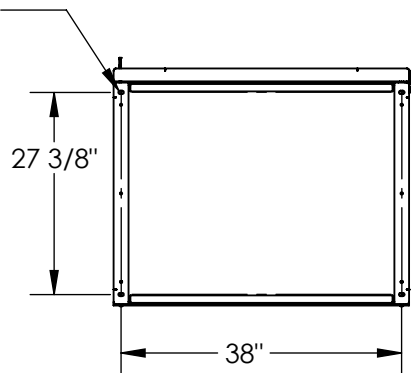

STANDARD FEATURES

- MODEL NUMBER IS CYL-EX-12-S
- OVERALL WIDTH IS 40"
- OVERALL LENGTH IS 32 1/8"
- OVERALL HEIGHT IS 44 1/8"
- HEIGHT BETWEEN SHELVES IS 19 5/8", 21 1/4"
- SOLID METAL DOOR
- MAX CAPACITY IS 6 TANKS PER SHELF
- SHELF UNIFORM CAPACITY IS 170 LBS.
- TOTAL UNIFORM CAPACITY IS 340 LBS.
- DOOR IS RIVETED ON TO UNIT
- TOUGH BAKED IN POWDER COATED WHITE FINISH
- INCLUDES LAG HOLES (LAG HARDWARE NOT INCLUDED)
- INCLUDES RED LETTER SIGNAGE:
 "PROPANE EXCHANGE, FLAMMABLE, NO SMOKING" (NOT SHOWN)

SPECIAL FEATURES

NONE

APPROVAL

I, THE UNDERSIGNED, AGREE THAT THE PRODUCT AS REPRESENTED SATISFIES DESIGN AND DIMENSION REQUIREMENTS. I ALSO ACKNOWLEDGE MY DUTY TO CONFIRM PRODUCT AND INSTALLATION COMPLIANCE WITH ALL APPLICABLE FEDERAL, STATE AND LOCAL REGULATIONS AND STANDARDS.

ANY MODIFIED UNITS ARE NON-RETURNABLE

[] As drawn [] As marked

Signed: _____ Date: _____

Printed Name: _____

LEAD TIME WILL START UPON RECEIPT OF SIGNED APPROVAL DRAWING

DISTRIBUTOR'S NAME:		P.O.#
VESTIL MANUFACTURING		X
DRAWN BY: CRM		W.O.#
DATE: 11/15/2010		X
REFERENCE: X	SCALE: 1:16	SALES: X
QUOTED LEAD TIME: X	QUOTE #	FILE NAME:
	X	31-007-126