

# CROSS OVER LADDER, VERTICAL - COLV-4-46-8

APPROX WEIGHT: 187.35 lbs.  
 DOES NOT INCLUDE WEIGHT OF POWER OR PACKAGING!!!

\*\*\* ANY ADDITIONS, DELETIONS, OR OMISSIONS MUST BE CORRECTED ON THIS DRAWING AS THIS DRAWING WILL BE CONSIDERED ALL INCLUSIVE \*\*\*

ALL GRAPHICS PROVIDED ARE FOR REFERENCE ONLY. IF CERTAIN DIMENSIONS ARE CRITICAL PLEASE VERIFY THOSE DIMENSIONS WITH YOUR SALESPERSON

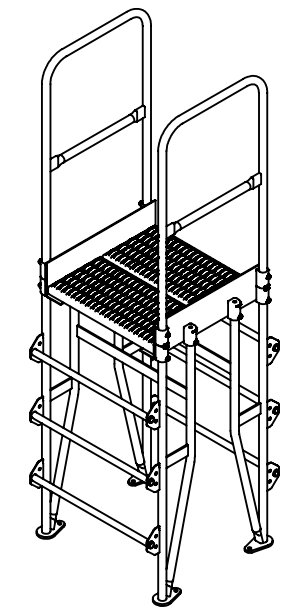
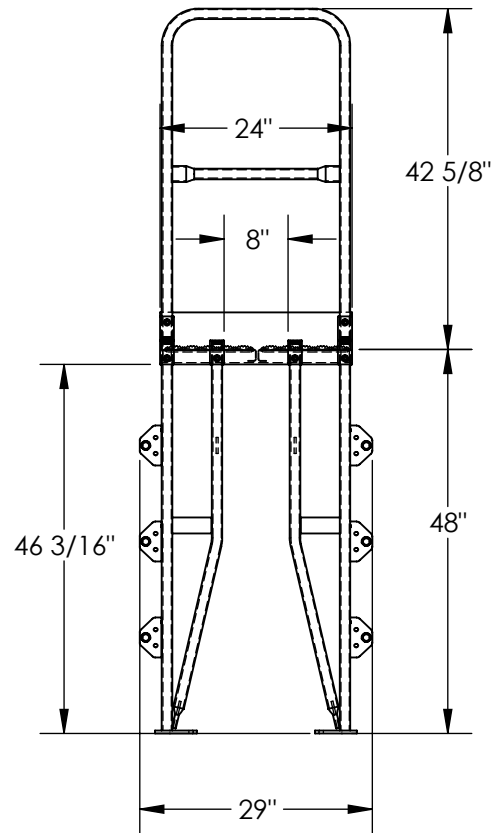
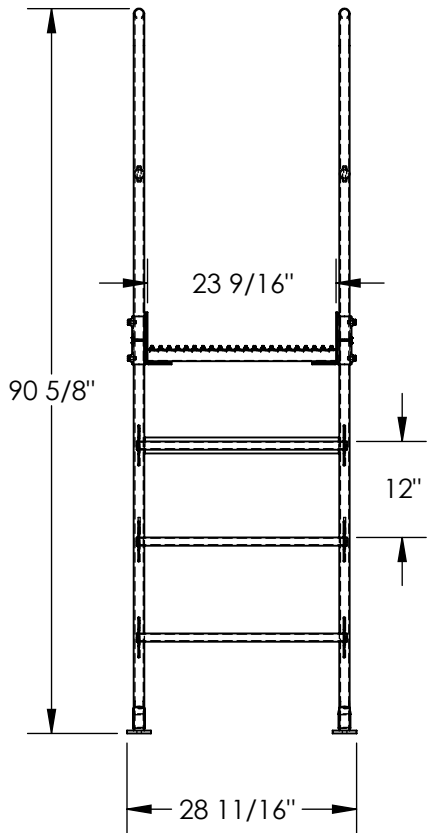

DIMENSION TOLERANCE ± 1/4"

## STANDARD FEATURES

- MODEL NUMBER IS COLV-4-46-8
- OVERALL SIZE IS 28 11/16"W x 29" L x 90 5/8" H
- CLEARANCE SPAN IS 8" x 46 3/16"
- TOP PLATFORM HEIGHT IS 48"
- STEP HEIGHT SPACING IS 12"
- STEP & PLATFORM WIDTH IS 23 9/16"
- HANDRAIL HEIGHT IS 42 5/8"
- PLATFORM LENGTH IS 24"
- ALL PLATFORM STEPS ARE SERRATED STEEL
- TOP HALF OF STEPS COVERED IN GRIP MATERIAL
- KNOCK DOWN HANDRAILING (UNIT SHIPS KNOCKED DOWN, ASSEMBLY REQUIRED)
- UNIFORM CAPACITY IS 500 LBS
- TOUGH BAKED IN POWDER COATED YELLOW FINISH

## NOTE

- UNIT MUST BE ANCHORED TO THE FLOOR!!!
- Ø9/16" MOUNTING HOLES
- 4 TOTAL MOUNTING HOLES PER STANDARD UNIT
- 1 MOUNTING HOLE PER CORNER BRACKET

## SPECIAL FEATURES

NONE

FOR INTERNAL USE ONLY PROJECT SIGN OFF	
SALES	
ENG.	
FAB.	
POWER	

<b>APPROVAL</b>	I, THE UNDERSIGNED, AGREE THAT THE PRODUCT AS REPRESENTED SATISFIES DESIGN AND DIMENSION REQUIREMENTS. I ALSO ACKNOWLEDGE MY DUTY TO CONFIRM PRODUCT AND INSTALLATION COMPLIANCE WITH ALL APPLICABLE FEDERAL, STATE AND LOCAL REGULATIONS AND STANDARDS.	
	<b>ANY MODIFIED UNITS ARE NON-RETURNABLE</b>	
	[ ] As drawn      [ ] As marked	
	Signed: _____ Date: _____	
Printed Name: _____		
<b>LEAD TIME WILL START UPON RECEIPT OF SIGNED APPROVAL DRAWING</b>		

DISTRIBUTOR'S NAME:		P.O.#
<b>VESTIL MANUFACTURING</b>		X
		W.O.#
DRAWN BY: BCN	DATE: 5/21/2018	X
REFERENCE: X	SCALE: 1:24	FILE NAME:
QUOTED LEAD TIME: X	QUOTE #	44-007-605
	X	