

CARDBOARD BALER - CBB-3000-37

APPROX WEIGHT: 3865 lbs.
DOES NOT INCLUDE WEIGHT OF POWER OR PACKAGING!!!

*** ANY ADDITIONS, DELETIONS, OR OMISSIONS MUST BE CORRECTED ON THIS DRAWING AS THIS DRAWING WILL BE CONSIDERED ALL INCLUSIVE ***

ALL GRAPHICS PROVIDED ARE FOR REFERENCE ONLY. IF CERTAIN DIMENSIONS ARE CRITICAL PLEASE VERIFY THOSE DIMENSIONS WITH YOUR SALESPERSON

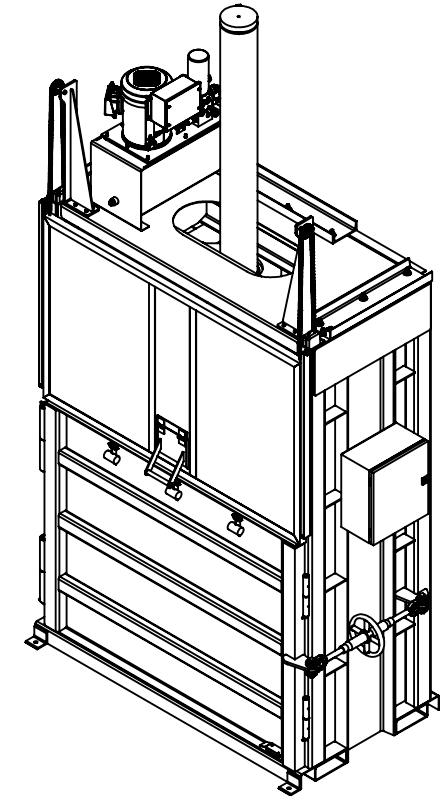
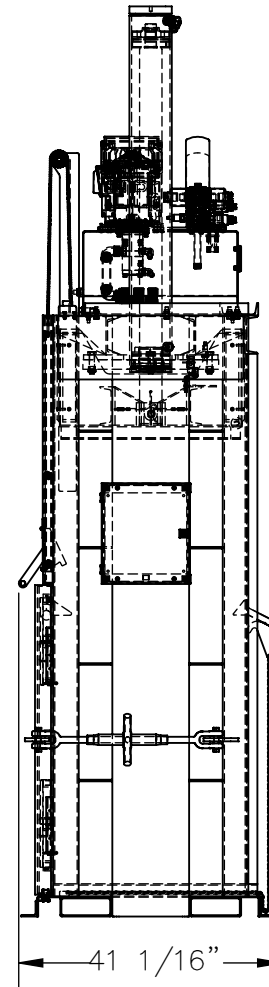
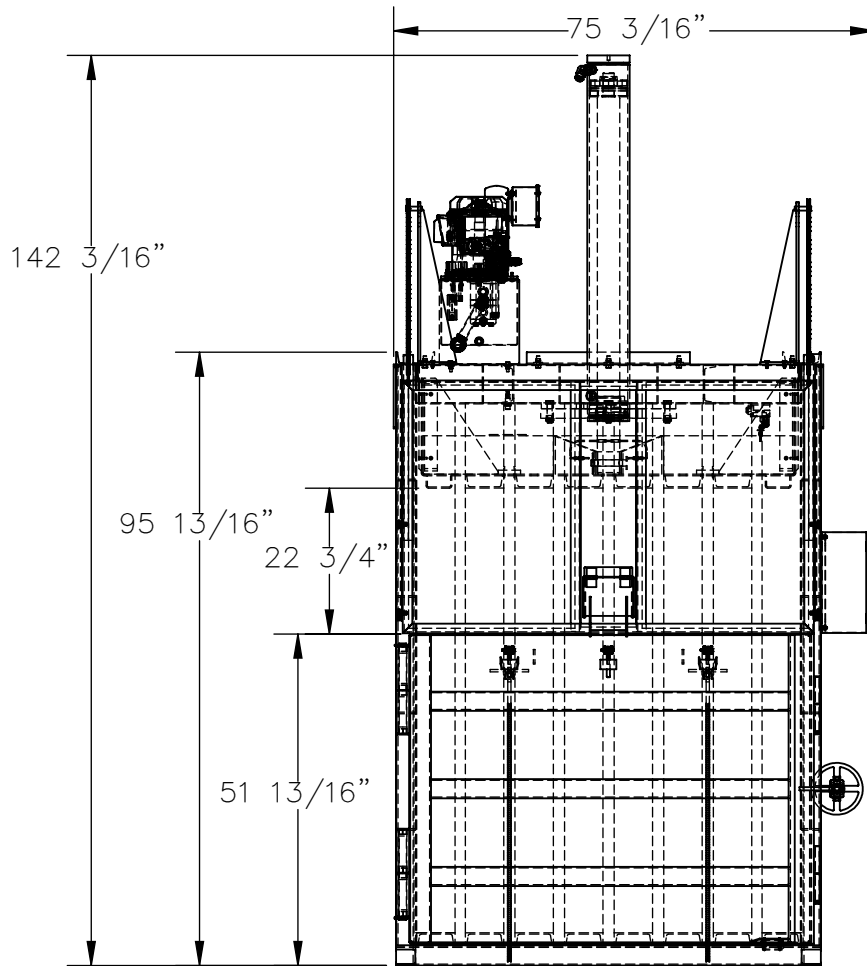

DIMENSION TOLERANCE $\pm 1/2"$

STANDARD FEATURES

- MODEL NUMBER IS CBB-3000-37
- OVERALL WIDTH: 75 3/16"
- OVERALL DEPTH: 41 1/16"
- OVERALL HEIGHT: 142 3/16"
- SHIPPING HEIGHT: 95 13/16"
- LOADING HEIGHT: 51 13/16"
- LOAD OPENING HEIGHT: 22 3/4"
- BALE SIZE: 60"L x 30"D x 42"H
- APPROX. BALE WEIGHT: 1100 \pm 100 LBS
- MAX CYLINDER FORCE: 2100 PSI
- APPROX CYCLE TIME: 60 SEC
- SEMI-AUTO BALE EJECTION SYSTEM
- FRAME IS DURABLE LIQUID PAINT BLUE FINISH
- GATE IS DURABLE LIQUID PAINT YELLOW FINISH

SPECIAL FEATURES

NONE

APPROVAL

I, THE UNDERSIGNED, AGREE THAT THE PRODUCT AS REPRESENTED SATISFIES DESIGN AND DIMENSION REQUIREMENTS. I ALSO ACKNOWLEDGE MY DUTY TO CONFIRM PRODUCT AND INSTALLATION COMPLIANCE WITH ALL APPLICABLE FEDERAL, STATE AND LOCAL REGULATIONS AND STANDARDS.

UNITS REQUIRING APPROVAL DRAWINGS OR MODIFIED ARE NON-RETURNABLE

As drawn As marked

Signed: _____ Date: _____

Printed Name: _____

LEAD TIME WILL START UPON RECEIPT OF SIGNED APPROVAL DRAWING

DISTRIBUTOR'S NAME:		P.O.#
VESTIL MANUFACTURING		X
DRAWN BY: CRH		DATE: 9/1/2020
REFERENCE: X		SCALE: 1:30
QUOTED LEAD TIME: X		QUOTE # X
		SALES: X
		FILE NAME: 22-007-023