

# LOW PROFILE DC POWERED HYDRAULIC SCISSOR LIFT CART - APPROX WEIGHT: 408 lbs. - DOES NOT INCLUDE WEIGHT OF POWER OR PACKAGING!!!

## CART-LP-2000-2040-DC

\*\*\* ANY ADDITIONS, DELETIONS, OR OMISSIONS MUST BE CORRECTED ON THIS DRAWING AS THIS DRAWING WILL BE CONSIDERED ALL INCLUSIVE \*\*\*  
 ALL GRAPHICS PROVIDED ARE FOR REFERENCE ONLY. IF CERTAIN DIMENSIONS ARE CRITICAL PLEASE VERIFY THOSE DIMENSIONS WITH YOUR SALESPERSON

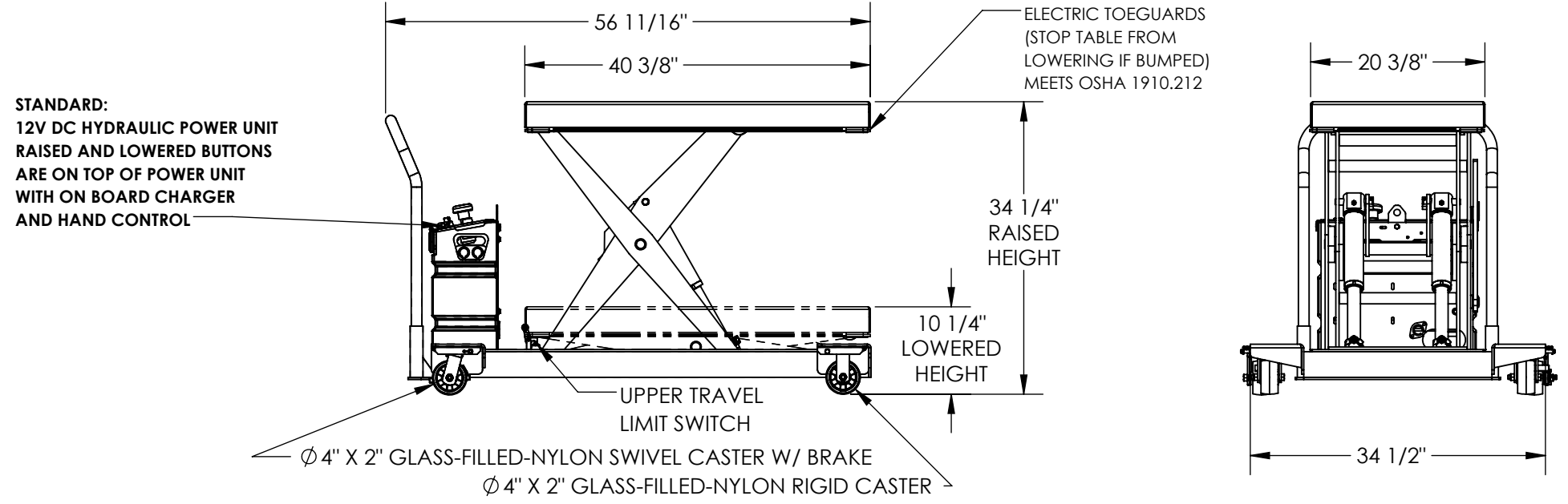

### STANDARD FEATURES

- MODEL NUMBER IS CART-LP-2000-2040-DC
- OVERALL WIDTH: 34 1/2"
- USABLE WIDTH: 20 3/8"
- OVERALL LENGTH: 56 11/16"
- USABLE LENGTH: 40 3/8"
- RAISED HEIGHT: 34 1/4"
- LOWERED HEIGHT: 10 1/4"
- Ø 4" X 2" GLASS-FILLED-NYLON RIGID CASTER
- Ø 4" X 2" GLASS-FILLED-NYLON SWIVEL CASTER W/ BRAKE
- TABLE CAPACITY (EVENLY DISTRIBUTED)
- MAX CAPACITY IS 2,000 LBS
- CONTROL IS HANDHELD 2 BUTTON, NEMA 4 PENDANT WITH MINIMUM 8' USABLE COIL CORD
- SAFETY MAINTENANCE PROPS, DISPLACEMENT STYLE CYLINDERS INSTALLED ROD DOWN
- EMERGENCY SAFETY STOP HYDRAULIC FUSES
- UPPER TRAVEL LIMIT SWITCH
- ELECTRIC PINCH POINT GUARD
- DURABLE LIQUID PAINT BLUE FINISH

DECK TOLERANCE ± 1/2"  
 TABLE HEIGHT TOLERANCES ± 1/2"  
 DECK FLATNESS ± 1/4"

DIMENSION TOLERANCE ± 1/4"

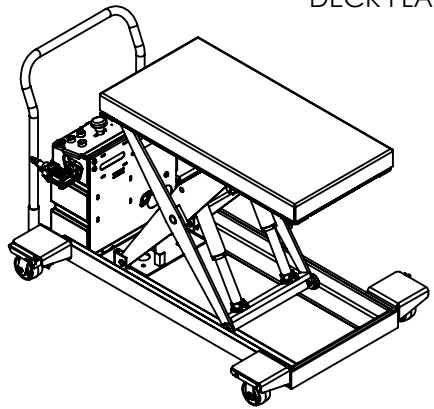

**A P P R O V A L**

I, THE UNDERSIGNED, AGREE THAT THE PRODUCT AS REPRESENTED SATISFIES DESIGN AND DIMENSION REQUIREMENTS. I ALSO ACKNOWLEDGE MY DUTY TO CONFIRM PRODUCT AND INSTALLATION COMPLIANCE WITH ALL APPLICABLE FEDERAL, STATE AND LOCAL REGULATIONS AND STANDARDS.

**UNITS REQUIRING APPROVAL DRAWINGS OR MODIFIED ARE NON-RETURNABLE**

[ ] As drawn [ ] As marked

Signed: \_\_\_\_\_ Date: \_\_\_\_\_

Printed Name: \_\_\_\_\_

LEAD TIME WILL START UPON RECEIPT OF SIGNED APPROVAL DRAWING

### SPECIAL FEATURES

NONE

FOR INTERNAL USE ONLY PROJECT SIGN OFF	
SALES	
ENG.	
FAB.	
POWER	

DISTRIBUTOR'S NAME:		P.O.#
VESTIL MANUFACTURING		X
W.O.#		X
DRAWN BY: CRA	DATE: 06/14/2019	SALES: X
REFERENCE: X	SCALE: 1:18	FILE NAME:
QUOTED LEAD TIME: X	QUOTE # X	01-007-405