

# FOOT PUMP HYDRAULIC SCISSOR LIFT CART-CART-2500-2040-FP

APPROX WEIGHT: 350.94 lbs.  
 DOES NOT INCLUDE WEIGHT OF POWER OR PACKAGING!!!

\*\*\* ANY ADDITIONS, DELETIONS, OR OMISSIONS MUST BE CORRECTED ON THIS DRAWING AS THIS DRAWING WILL BE CONSIDERED ALL INCLUSIVE \*\*\*  
 ALL GRAPHICS PROVIDED ARE FOR REFERENCE ONLY. IF CERTAIN DIMENSIONS ARE CRITICAL PLEASE VERIFY THOSE DIMENSIONS WITH YOUR SALESPERSON

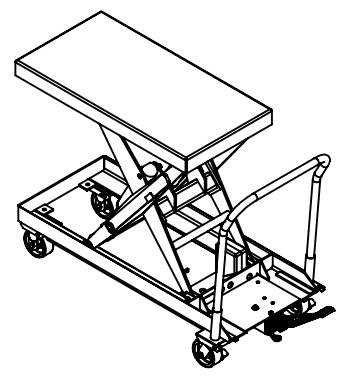
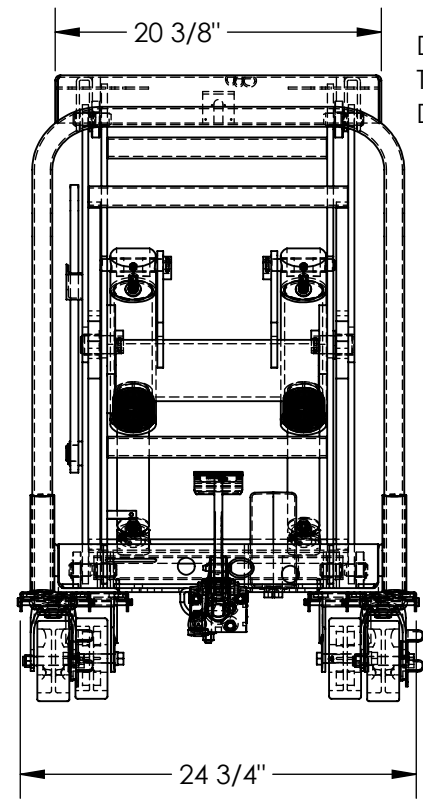
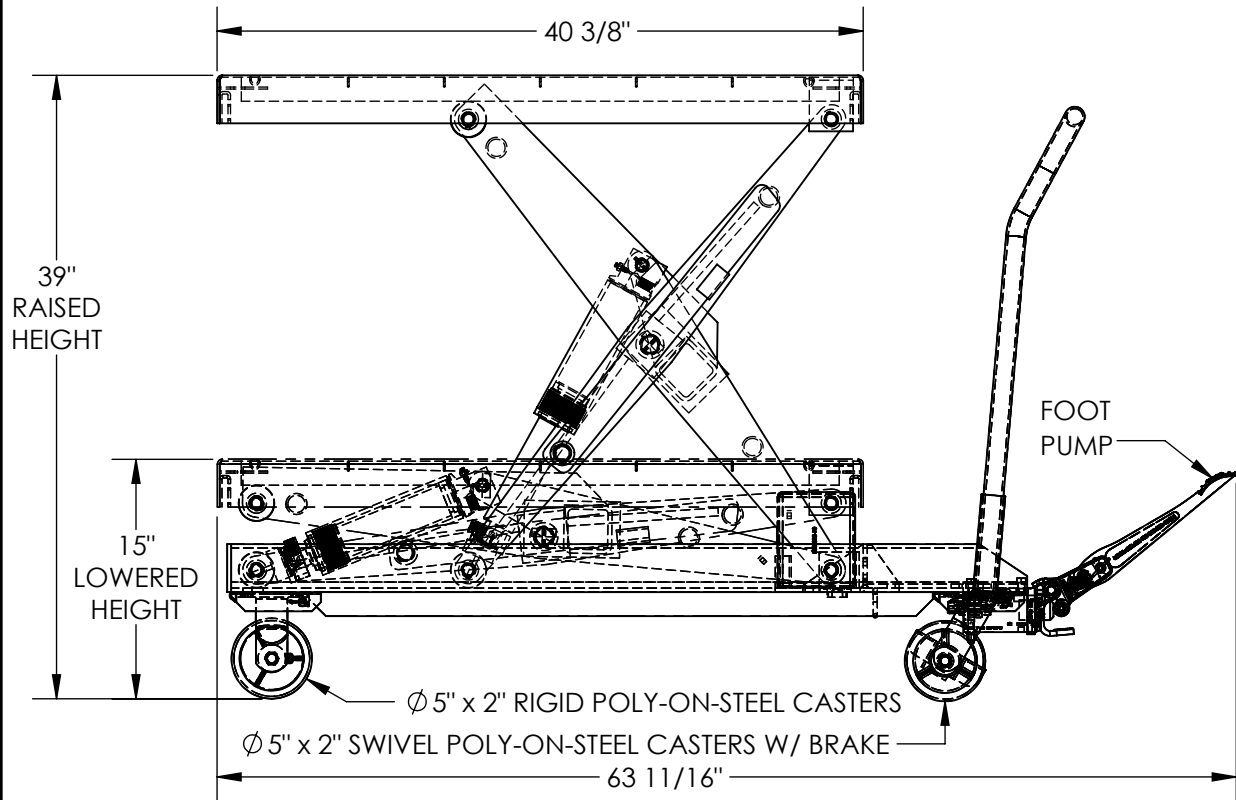

## STANDARD FEATURES

- MODEL NUMBER IS CART-2500-2040-FP
- OVERALL WIDTH IS 24 3/4"
- USABLE WIDTH IS 20 3/8"
- OVERALL LENGTH IS 63 11/16"
- USABLE LENGTH IS 40 3/8"
- RAISED HEIGHT IS 39"
- LOWERED HEIGHT IS 15"
- Ø 5" x 2" RIGID POLY-ON-STEEL CASTERS
- Ø 5" x 2" SWIVEL POLY-ON-STEEL CASTERS W/ BRAKE
- TABLE CAPACITY (EVENLY DISTRIBUTED)
- MAX CAPACITY IS 2,500 LBS
- SAFETY MAINTENANCE PROPS, DISPLACEMENT STYLE CYLINDERS INSTALLED ROD DOWN
- EMERGENCY SAFETY STOP HYDRAULIC FUSES
- TWO SPEED AUTO SHIFTING MANUAL FOOT PUMP
- NUMBER OF PUMPS TO RAISE TABLE
- LOW PRESSURE: 36
- HIGH PRESSURE: 100
- DURABLE LIQUID PAINT BLUE FINISH

## SPECIAL FEATURES

NONE

DIMENSION TOLERANCE ± 1/4"

**APPROVAL**

I, THE UNDERSIGNED, AGREE THAT THE PRODUCT AS REPRESENTED SATISFIES DESIGN AND DIMENSION REQUIREMENTS. I ALSO ACKNOWLEDGE MY DUTY TO CONFIRM PRODUCT AND INSTALLATION COMPLIANCE WITH ALL APPLICABLE FEDERAL, STATE AND LOCAL REGULATIONS AND STANDARDS.

**ANY MODIFIED UNITS ARE NON-RETURNABLE**

As drawn       As marked

Signed: \_\_\_\_\_ Date: \_\_\_\_\_

Printed Name: \_\_\_\_\_

**LEAD TIME WILL START UPON RECEIPT OF SIGNED APPROVAL DRAWING**

FOR INTERNAL USE ONLY PROJECT SIGN OFF	
SALES	
ENG.	
FAB.	
POWER	

DISTRIBUTOR'S NAME:		P.O.#
VESTIL MANUFACTURING		X
DRAWN BY: CRA	DATE: 09/12/2017	W.O.#
REFERENCE: X	SCALE: 1:12	X
QUOTED LEAD TIME: X	QUOTE #	FILE NAME:
	X	01-007-358