

FOOT PUMP SCISSOR TABLE - CART-1500-D-TS

*** ANY ADDITIONS, DELETIONS, OR OMISSIONS MUST BE CORRECTED ON THIS DRAWING AS THIS DRAWING WILL BE CONSIDERED ALL INCLUSIVE ***
 ALL GRAPHICS PROVIDED ARE FOR REFERENCE ONLY. IF CERTAIN DIMENSIONS ARE CRITICAL PLEASE VERIFY THOSE DIMENSIONS WITH YOUR SALESPERSON

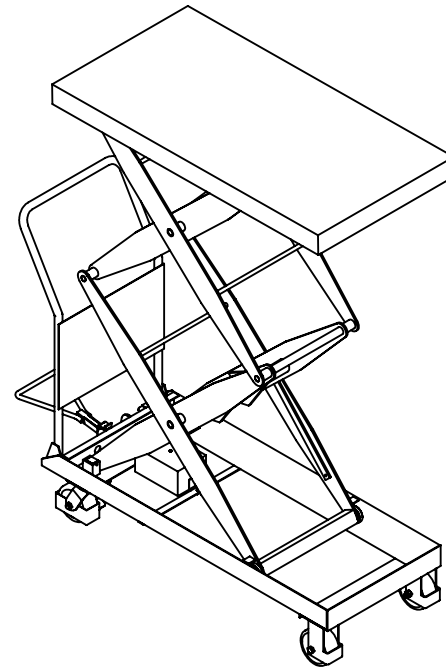
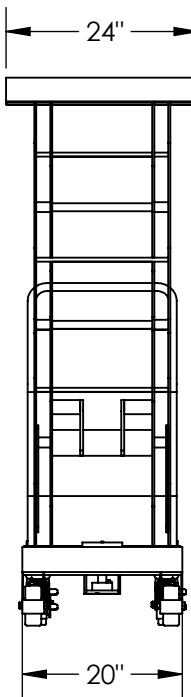
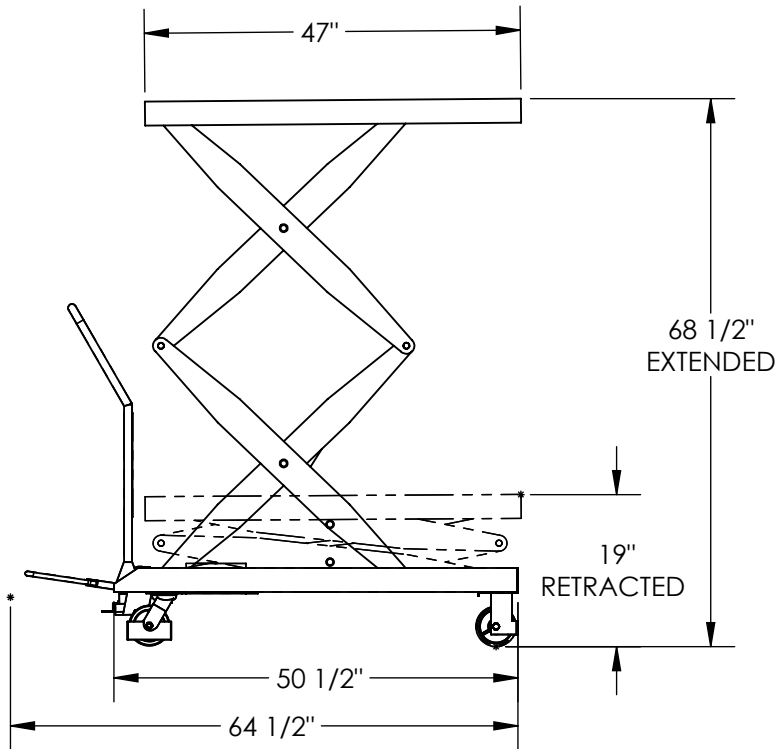

DIMENSION TOLERANCE ± 1/2"

STANDARD FEATURES

- MODEL NUMBER IS CART-1500-D-TS
- CAPACITY: 1,500 LBS
- DECK SIZE: 24" W X 47" L
- RAISED HEIGHT IS 68 1/2"
- LOWERED HEIGHT IS 19"
- OVERALL HEIGHT IS 39 1/2" (HANDLE HEIGHT)
- OVERALL LENGTH IS 64 1/2"
- OVERALL WIDTH IS 24"
- FOOT PEDAL RELEASE VALVE
- # OF PUMPS AT HIGH/LOW SPEED
 - HIGH: 59 PUMPS
 - LOW: 102 PUMPS
- CASTERS - POLY ON STEEL
 - (2) 6 X 1 1/2 RIGID
 - (2) 6 X 1 1/2 SWIVEL

SPECIAL FEATURES

NONE

APPROVAL

I, THE UNDERSIGNED, AGREE THAT THE PRODUCT AS REPRESENTED SATISFIES DESIGN AND DIMENSION REQUIREMENTS. I ALSO ACKNOWLEDGE MY DUTY TO CONFIRM PRODUCT AND INSTALLATION COMPLIANCE WITH ALL APPLICABLE FEDERAL, STATE AND LOCAL REGULATIONS AND STANDARDS.

ALL SPECIAL UNITS ARE NON-RETURNABLE

[] As drawn [] As marked

Signed: _____ Date: _____

LEAD TIME WILL START UPON RECEIPT OF SIGNED APPROVAL DRAWING

FOR INTERNAL USE ONLY
PROJECT SIGN OFF

SALES	
ENG.	
FAB.	
POWER	

DISTRIBUTOR'S NAME: VESTIL MANUFACTURING	
DRAWN BY: W.BURKHART	DATE: 09/05/14
REFERENCE: X	SCALE: 1:24
QUOTED LEAD TIME: X	QUOTE # X

P.O.# X
W.O.# X
SALES: X
FILE NAME: 01-007-115