

# TIN BOTTLE WITH BRUSH LID - BTL-MTB-32

APPROX WEIGHT: 5 OZ.  
 DOES NOT INCLUDE WEIGHT OF POWER OR PACKAGING!!!

\*\*\* ANY ADDITIONS, DELETIONS, OR OMISSIONS MUST BE CORRECTED ON THIS DRAWING AS THIS DRAWING WILL BE CONSIDERED ALL INCLUSIVE \*\*\*

ALL GRAPHICS PROVIDED ARE FOR REFERENCE ONLY. IF CERTAIN DIMENSIONS ARE CRITICAL PLEASE VERIFY THOSE DIMENSIONS WITH YOUR SALESPERSON

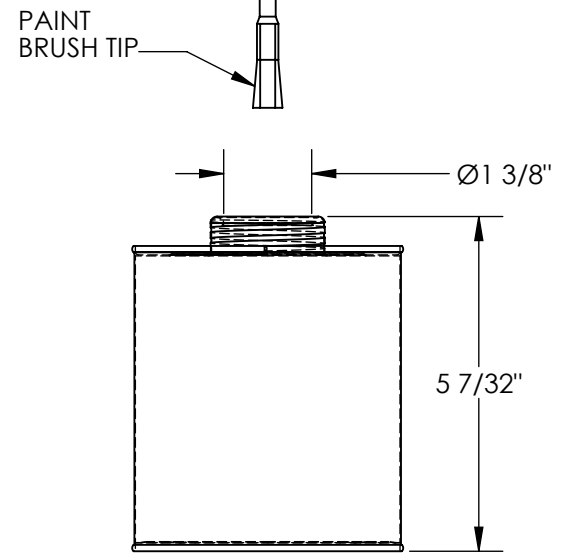
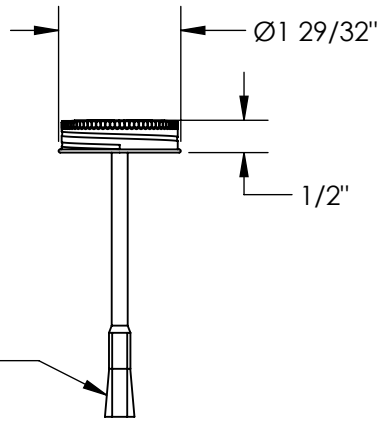
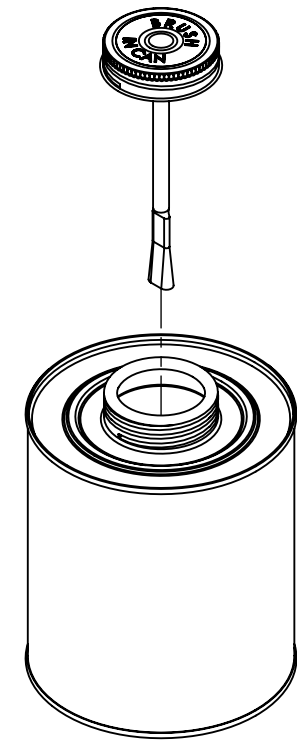
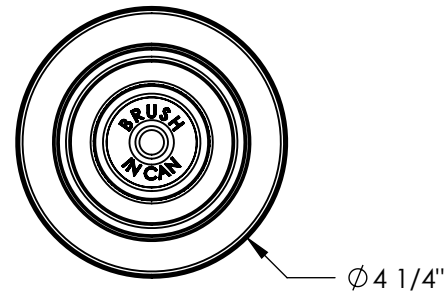

## STANDARD FEATURES

MODEL NUMBER IS BTL-MTB-32  
 OVERALL DIAMETER IS: 4 1/4"  
 OVERALL HEIGHT IS: 5 7/32"  
 MAX CAPACITY IS: 32 OZ.

## SPECIAL FEATURES

NONE

<b>A P P R O V A L</b>	I, THE UNDERSIGNED, AGREE THAT THE PRODUCT AS REPRESENTED SATISFIES DESIGN AND DIMENSION REQUIREMENTS. I ALSO ACKNOWLEDGE MY DUTY TO CONFIRM PRODUCT AND INSTALLATION COMPLIANCE WITH ALL APPLICABLE FEDERAL, STATE AND LOCAL REGULATIONS AND STANDARDS.	
	<b>ALL SPECIAL UNITS ARE NON-RETURNABLE</b>	
	[ ] As drawn [ ] As marked	
Signed: _____		Date: _____
LEAD TIME WILL START UPON RECEIPT OF SIGNED APPROVAL DRAWING		

DISTRIBUTOR'S NAME:		P.O.#
VESTIL MANUFACTURING		X
DRAWN BY: T. MOORE		W.O.#
DATE: 04/01/11		X
REFERENCE: X	SCALE: 1:3	SALES: X
QUOTED LEAD TIME: X	QUOTE #	FILE NAME:
	X	30-007-892-001