

ALUMINUM WALK RAMP (OVERLAP MT STYLE) - AWR-38-4A

APPROX WEIGHT: 63.02 lbs.
 DOES NOT INCLUDE WEIGHT OF POWER OR PACKAGING!!!

*** ANY ADDITIONS, DELETIONS, OR OMISSIONS MUST BE CORRECTED ON THIS DRAWING AS THIS DRAWING WILL BE CONSIDERED ALL INCLUSIVE ***
 ALL GRAPHICS PROVIDED ARE FOR REFERENCE ONLY. IF CERTAIN DIMENSIONS ARE CRITICAL PLEASE VERIFY THOSE DIMENSIONS WITH YOUR SALESPERSON

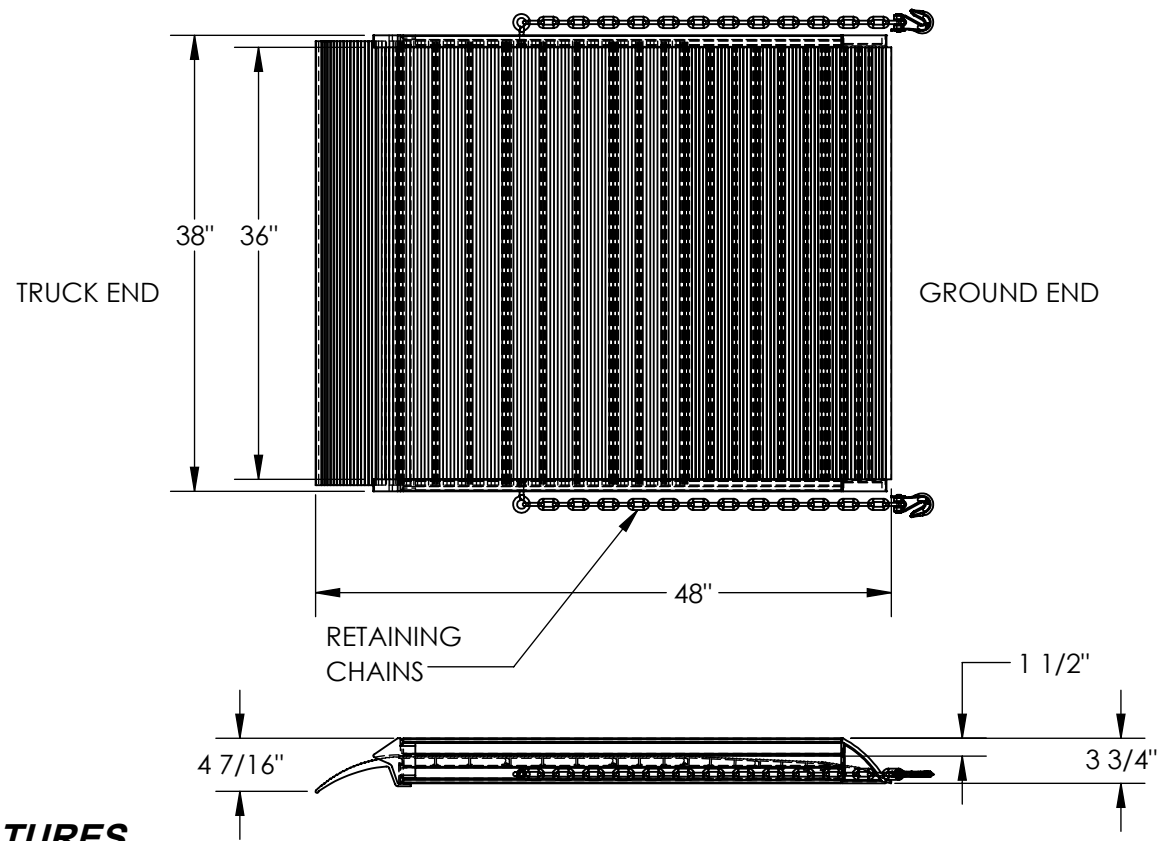

STANDARD FEATURES

- MODEL NUMBER IS AWR-38-4A
- OVERALL RAMP WIDTH IS 38"
- USABLE WIDTH IS 36"
- OVERALL LENGTH IS 48"
- OVERALL HEIGHT IS 4 7/16"
- USABLE CURB HEIGHT IS 1 1/2"
- HEIGHT SERVICE RANGE IS 6"-13"
- OVERLAP STYLE
- ALUMINUM CONSTRUCTION
- 4 WHEEL CAPACITY IS 3,000 LBS
- 2 WHEEL CAPACITY IS 2,200 LBS

SPECIAL FEATURES

NONE

**SPECIAL UNITS ARE NON-RETURNABLE
 *AVAILABLE AT ADDITIONAL COSTS

DIMENSION TOLERANCE ± 1/2"

A P P R O V A L	I, THE UNDERSIGNED, AGREE THAT THE PRODUCT AS REPRESENTED SATISFIES DESIGN AND DIMENSION REQUIREMENTS. I ALSO ACKNOWLEDGE MY DUTY TO CONFIRM PRODUCT AND INSTALLATION COMPLIANCE WITH ALL APPLICABLE FEDERAL, STATE AND LOCAL REGULATIONS AND STANDARDS.	
	ANY MODIFIED UNITS ARE NON-RETURNABLE	
	[] As drawn	[] As marked
	Signed: _____ Date: _____	
Printed Name: _____		
LEAD TIME WILL START UPON RECEIPT OF SIGNED APPROVAL DRAWING		

FOR INTERNAL USE ONLY PROJECT SIGN OFF	
SALES	
ENG.	
FAB.	
POWER	

DISTRIBUTOR'S NAME:		P.O.#
VESTIL MANUFACTURING		X
W.O.#		X
DRAWN BY: MTS	DATE: 03/02/2018	SALES: X
REFERENCE: X	SCALE: 1:16	FILE NAME:
QUOTED LEAD TIME: X	QUOTE # X	18-007-326