

ALTERNATING TREAD STAIR - ATS-13-56

APPROX WEIGHT: 350.41 lbs.
 DOES NOT INCLUDE WEIGHT OF POWER OR PACKAGING!!!

ANY ADDITIONS, DELETIONS, OR OMISSIONS MUST BE CORRECTED ON THIS DRAWING AS THIS DRAWING WILL BE CONSIDERED ALL INCLUSIVE

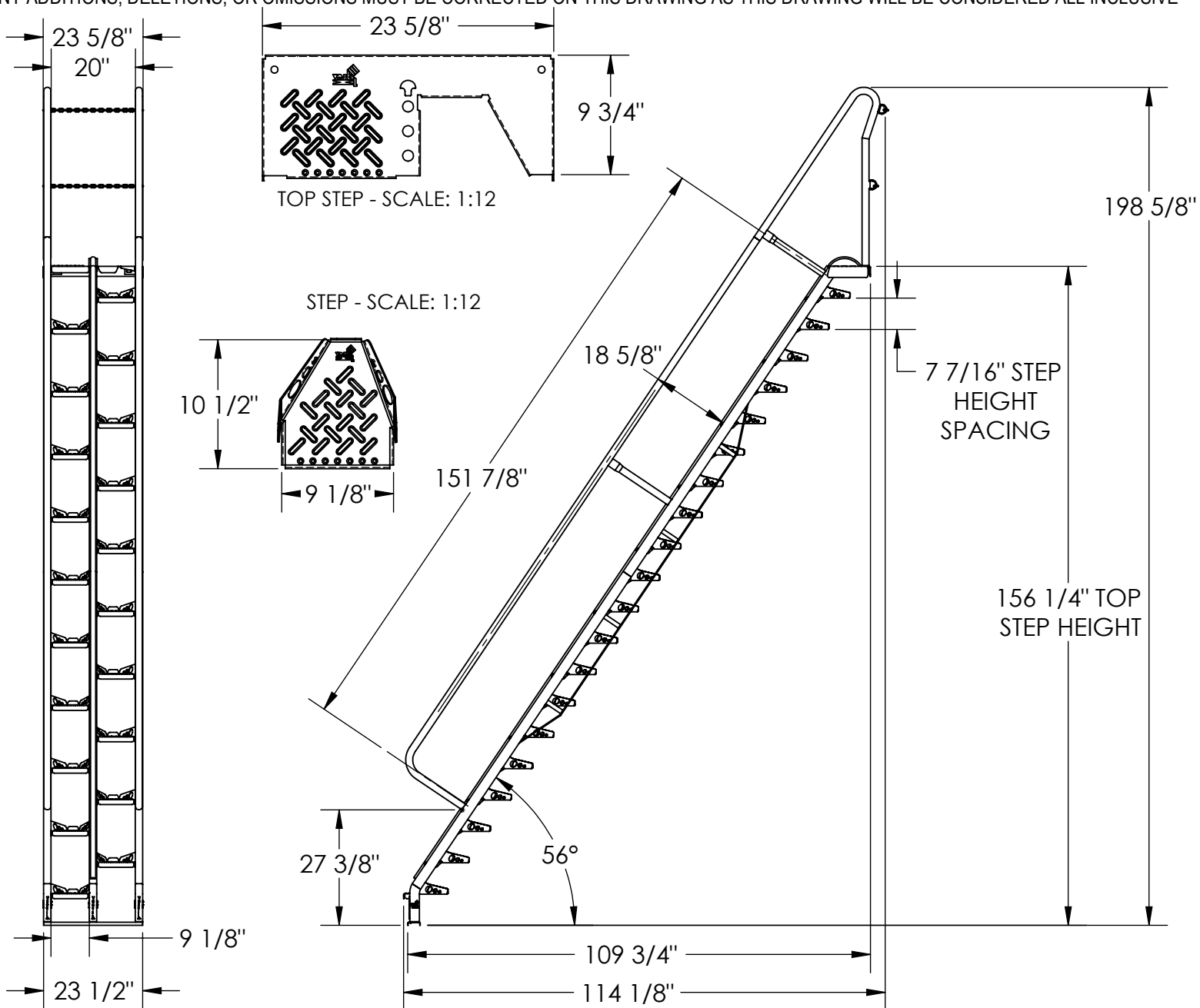

ALL GRAPHICS PROVIDED ARE FOR REFERENCE ONLY. IF CERTAIN DIMENSIONS ARE CRITICAL PLEASE VERIFY THOSE DIMENSIONS WITH YOUR SALESPERSON

DIMENSION TOLERANCE ± 1/4"

STANDARD FEATURES

- MODEL NUMBER: ATS-13-56
- CLIMB ANGLE: 56°
- NUMBER OF STEPS: 21 (INCLUDING TOP STEP)
- TOP STEP HEIGHT: 156 1/4"
- STEP HEIGHT SPACING: 7 7/16"
- HANDRAIL HEIGHT: 18 5/8"
- OVERALL HEIGHT: 198 5/8"
- OVERALL LENGTH: 114 1/8"
- OVERALL WIDTH: 23 1/2"
- CHAIN GATES AT TOP STEP
- RUBBER BUMPER STRIP
- MAX CAPACITY IS 350 LBS
- TOUGH BAKED IN POWDER COATED YELLOW FINISH

SPECIAL FEATURES

NONE

A P P R O V A L	I, THE UNDERSIGNED, AGREE THAT THE PRODUCT AS REPRESENTED SATISFIES DESIGN AND DIMENSION REQUIREMENTS. I ALSO ACKNOWLEDGE MY DUTY TO CONFIRM PRODUCT AND INSTALLATION COMPLIANCE WITH ALL APPLICABLE FEDERAL, STATE AND LOCAL REGULATIONS AND STANDARDS.	
	ANY MODIFIED UNITS ARE NON-RETURNABLE	
	[] As drawn [] As marked	
	Signed: _____ Date: _____	
Printed Name: _____		
<i>LEAD TIME WILL START UPON RECEIPT OF SIGNED APPROVAL DRAWING</i>		

FOR INTERNAL USE ONLY PROJECT SIGN OFF		DISTRIBUTOR'S NAME:		P.O.#	
		VESTIL MANUFACTURING		X	
SALES		DRAWN BY: B. WOOD		DATE: 4/22/2009	W.O.#
ENG.		REFERENCE: X		SCALE: 1:35	SALES: X
FAB.		QUOTED LEAD TIME: X		QUOTE #	FILE NAME:
POWER				X	44-007-364