

ADJ. STEEL GANTRY CRANE WITH DUAL TIRE PNEUMATIC CASTERS - AHS-4-20-14-PNU

APPROX WEIGHT: 1292.07 lbs.

(DOES NOT INCLUDE WEIGHT OF POWER OR PACKAGING!!!)

*** ANY ADDITIONS, DELETIONS, OR OMISSIONS MUST BE CORRECTED ON THIS DRAWING AS THIS DRAWING WILL BE CONSIDERED ALL INCLUSIVE ***

ALL GRAPHICS PROVIDED ARE FOR REFERENCE ONLY. IF CERTAIN DIMENSIONS ARE CRITICAL PLEASE VERIFY THOSE DIMENSIONS WITH YOUR SALESPERSON

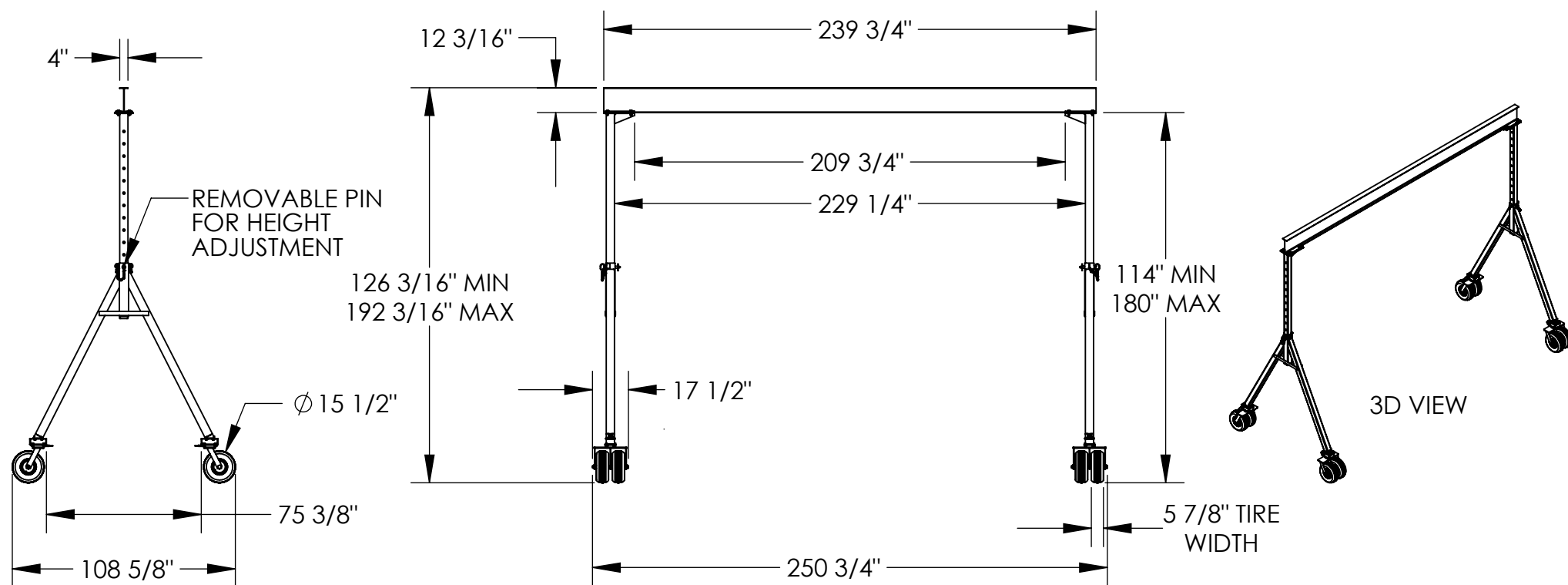

DIMENSION TOLERANCE $\pm 1/4"$

STANDARD FEATURES

- MODEL NUMBER IS AHS-4-20-14-PNU
- CAPACITY IS 4,000 LBS.
- BASE WIDTH IS 108 5/8"
- MAX OVERALL HEIGHT IS 192 3/16"
- I-BEAM HEIGHT IS 12 3/16"
- I-BEAM WIDTH IS 4"
- OVERALL I-BEAM LENGTH IS 239 3/4"
- USABLE I-BEAM LENGTH IS 209 3/4"
- ADJUSTABLE UNDER I-BEAM HEIGHT 180"
- HEIGHT IS ADJUSTABLE IN 6" INCREMENTS
- (4) $\phi 15 1/2"$ DUAL TIRE PNEUMATIC CASTERS (SWIVEL WITH (4) LOCKING POSITIONS)
- PNU MODELS ARE 12" TALLER THAN STANDARD
- AHS UNITS OF THE SAME HEIGHT DESIGNATION
- DURABLE LIQUID PAINT BLUE FINISH

SPECIAL FEATURES

NONE

APPROVAL

I, THE UNDERSIGNED, AGREE THAT THE PRODUCT AS REPRESENTED SATISFIES DESIGN AND DIMENSION REQUIREMENTS. I ALSO ACKNOWLEDGE MY DUTY TO CONFIRM PRODUCT AND INSTALLATION COMPLIANCE WITH ALL APPLICABLE FEDERAL, STATE AND LOCAL REGULATIONS AND STANDARDS.

UNITS REQUIRING APPROVAL DRAWINGS OR MODIFIED ARE NON-RETURNABLE

As drawn As marked

Signed: _____ Date: _____

Printed Name: _____

LEAD TIME WILL START UPON RECEIPT OF SIGNED APPROVAL DRAWING

DISTRIBUTOR'S NAME:		P.O.#
VESTIL MANUFACTURING		X
DRAWN BY: MTS		DATE: 01/29/2021
REFERENCE: X		SCALE: 1:72
QUOTED LEAD TIME: X		QUOTE # X
		SALES: X
		FILE NAME: 28-007-481